

**STUDY REPORT**

*Final*

**General Info. No. 8**

**MAA-AE-18-010**

**TASK NO. 8520**

**MEP CAPACITY STUDY FOR AIRPORT CONCESSIONS AT  
BWI MARSHALL AIRPORT**



**NOVEMBER 30, 2021**

---

## TABLE OF CONTENTS

---

<b>I.</b>	<b>EXECUTIVE SUMMARY .....</b>	<b>3</b>
	A. Introduction .....	3
	B. Study Objective/Project Approach .....	3
	C. Summary of Findings.....	3
<b>II.</b>	<b>STUDY REPORT .....</b>	<b>4</b>
	A. Study Objective .....	4
	B. Mechanical.....	4
	C. Plumbing .....	4
	D. Electrical.....	5
	E. Information Communications Technology (ICT) & Security Systems Availability .....	5
	F. Fire Protection (Sprinkler and Fire Alarm).....	8
<b>III.</b>	<b>APPENDICES.....</b>	<b>9</b>
	<b>Appendix A – Exhibits</b>	
	<b>Appendix B – Design Review Comments with Responses</b>	
<b>IV.</b>	<b>DESIGN REPORT GENERAL INFORMATION</b>	

---

## I. EXECUTIVE SUMMARY

---

### A. Introduction

This Study Report provides an overview of the available capacity of the mechanical, plumbing, electrical, information technology and security, and fire protection systems that are currently available at the Baltimore/Washington International Thurgood Marshall Airport (BWI Marshall Airport or Airport) to support the concession program. This information will provide an understanding of the building services that are available to support future concession development.

### B. Study Objective/Project Approach

The objective of the study is to document, at a high level, the capacity available in the mechanical, plumbing, electrical, information technology and security, and fire protection systems at the BWI Marshall Airport Main Terminal and the connecting Concourses A, B, C, D and E to support the concessionaires.

The available capacities in the study are a high level view of the existing systems and provide a starting point to aid concession development. A detailed engineering analysis should be performed as part of any concessionaires development in order to confirm available capacity.

The study is based on a review of existing plans, site walk-thrus, coordination with the Maryland Department of Transportation Maryland Aviation Administration (MDOT MAA), review of existing metering data and HVAC control system data, and analysis to calculate available spare capacity.

### C. Summary of Findings

1. Mechanical: The concession spaces are generally served by variable air volume (VAV) boxes and re-heat coils connected to the existing BWI Marshall Airport air handling units (AHUs). Select concession spaces contain additional HVAC equipment to supplement the concession-specific loads. In general, the BWI Marshall Airport AHUs do not appear to have spare capacity to add VAVs for additional concession loads. The areas served by each AHU are colored coded on the drawings and the concession spaces are noted with the existing VAV or heating coil serving the space, including the maximum cubic feet per minute (CFM) of the VAV.

For new concessions and concessions with a change-in-use or added loads, it is assumed they will add in separate mechanical units to serve their load profile beyond the capacity of the respective house VAV or heating coil serving the space.

2. Plumbing: The existing domestic cold water, hot water, sanitary and gas mains are shown on the floor plans. Estimated spare capacities of the plumbing mains are included, except for gas. The existing plumbing piping sizes to the concession spaces, where applicable, are noted along with the estimated spare capacity available.
3. Electrical: The concession spaces are served by various electrical substations. The substations have available capacity to support future concessionaire development. The general areas served by the substations are colored coded on the drawings along with the peak demand for each substation and the estimated spare capacity for additional concession loads.
4. Information Communications Technology (ICT) and Security: ICT and Security Systems deployed at BWI Marshall Airport are typically not limited by system capacity availability but rather the Division of Airport Technology (DAT) and Office of Airport Security concessionaire use policies. Use of MDOT MAA airport owned and operated systems is limited to only MDOT MAA entities. However, ICT services are available to concessionaires operating on airport property by agreements with other service providers operating at the airport. These agreements are arranged by the concessionaire in conjunction with the Office of Commercial Management and any associated Shared Tenant Service offerings and agreements. Please see the Information Communications Technology (ICT) & Security Systems section for additional information regarding infrastructure, network, internet, cable television, telephony, mass notification, and security system details.
5. Fire Protection (sprinkler): The BWI Marshall Airport Main Terminal and Concourses are classified as Ordinary Hazard, Group II and are fully sprinklered. Since the existing complex is already fully sprinklered and we do not anticipate that future concession work will be at a higher hazard level, any modifications to concession spaces should not require any significant fire protection upgrades.
6. Fire Protection (fire alarm): The concession spaces are served by multiple fire alarm panels. The panels have capacity to support future concessionaire development. The fire alarm panel locations are shown along with colored coded drawings indicating the approximate area served. The drawings also note the spare capacity for each of the fire alarm panels.

---

## II. STUDY REPORT

---

### A. Study Objective

To support the development and implementation of future concession program master plans at BWI Marshall Airport, this study documents at a high level, the capacity available in the mechanical, plumbing, electrical, information technology and security, and fire protection systems at the BWI Marshall Airport Main Terminal and the connecting Concourses A, B, C, D and E to support the concessionaires.

The available capacities in the study are a high level view of the existing systems and a starting point to aid concession development. A detailed engineering analysis should be performed as part of any concessionaires development in order to confirm available capacity.

The study is based on the following:

- Review of existing plans
- General visual site walk-thru to supplement information on plans; no above ceiling surveys were performed.
- Coordination with MDOT MAA –OMU and DAT
- Review of existing metering data in the web-based Schneider PowerLogic system
- Review of the existing HVAC control system in the web-based JCI Metasys system
- Analysis of existing data and calculations to determine available spare capacity

### B. Mechanical

The overall goal of this study is to determine the capacity of the existing BWI Marshall Airport “house” HVAC systems that feed the various concession areas. The building MEP drawings were reviewed and also, where available, the concession permit drawings to determine the concession areas served by the existing AHUs and VAVs.

In general, the AHUs do not appear to have spare capacity, as the connected load appears to exceed the AHU capacity, so any further evaluations would need to be performed during a design phase with a computerized load analysis and taking into consideration possible diversity factors of the spaces served. Therefore, spare capacities are not listed for the AHUs.

The existing JCI BMS system was reviewed in order to determine the designations and capacities of the house VAVs and re-heat coils that serve the concessions areas. In general, the VAV number that serves the concession area and the maximum design CFM of the VAV is indicated on the drawings. Concession support spaces are not included in this study, therefore the AHUs, VAVs and

re-heat coils serving these spaces on the ground floor are not noted. Additional and separate mechanical equipment from the airport house systems that serve the concession spaces, such as mini-split units, dedicated roof top units and dedicated make-up air units are also noted where available. Where sizes are available, they are noted. If additional mechanical equipment is not noted for a given concession space, then based on the drawings and the BMS system reviewed there do not appear to be additional mechanical units in those areas for supplemental conditioning.

Any concessionaires that replace a VAV or re-heat coil will be required to re-balance the respective AHU air system.

For new concessions and concessions with a change-in-use or added loads, it is assumed the concessionaires will add in separate mechanical units to serve their load profile beyond the capacity of the respective house VAV and re-heat coils serving the space.

Mechanical system installation shall conform to the latest version of the MDOT MAA Planning and Engineering Guidelines and Standards (PEGS) Manual. Link to copy: <https://public.airportal.maa.maryland.gov/pegs/#t=Home%2FHome.htm>

### C. Plumbing

The goal of this study is to determine the spare capacity of the plumbing systems for the general areas of the Concourse and each concession space. This analysis can become quite complex if more centralized equipment is incorporated, such as lift stations, gas meters & mains, water heaters, etc. upstream/downstream of the Concourse mains. Therefore the plumbing drawings show the estimated spare capacity of the local piping mains for the entire Concourse based on the connected loads in the Concourse using the fixture units for the existing loads subtracted from the code designated fixture unit capacity of the respective pipes. Each concession area that has plumbing piping is noted with the approximate size of the existing piping and also the spare capacity of those pipes relative to the existing equipment in the spaces. Each concession space’s spare capacity was calculated by subtracting the existing fixture units of equipment in the space from the code designated fixture unit capacity of the existing piping. Where a concession area does not list plumbing piping sizes or capacities, it appears that space does not currently have plumbing piping supply. Ground floor concession support spaces are not included in this study, therefore not all mains on the ground level are shown; only those associated with concession spaces.



The spare plumbing capacities are based on the capacity of the local piping systems and do not take into consideration upstream and downstream limitations. If additions are considered as part of the concessionaire development plan a more thorough engineering analysis of the plumbing system should be performed as part of the development.

The gas systems at BWI Marshall Airport are currently being studied by others to determine the capacity and pressure drop. The existing gas distribution system pressure at BWI Marshall Airport is 2 psi. It is understood that at least one of the summer boilers in Concourse A is not able to fire due to the gas system issues. One of the solutions BWI Marshall Airport is considering is to increase the gas pressure at the main utility gas train, which would be coupled with adding or modifying gas PRVs throughout the Airport to regulate the pressure to match the existing. The increase in pressure would change the spare capacity in the gas mains depending on the PRV locations, therefore the gas capacities are not listed in this study at this time. If the information is finalized, this study could be updated. For now, the gas main locations and sizes associated with the concessions in each concourse are shown.

C Pier specific sanitary issues: Any Food Concession or Capital washroom project on the C Pier should note the concourse sanitary outfalls to the street approximately 17 feet below the Lower Level concourse floor at the Vestibule Doors 10 LL. These drawings show the street outfall location for all sewage of C Pier to the existing Manhole 8T. Contract Number MAA-CO-10-004, dated January 2010 eliminated the 8 foot section of a W8 beam that was buried below the Lower Level Concourse floor just before the LL Concourse 10 Vestibule Doors. This was in addition to known obstruction(s) between column line KK and LL on Column 24 and the SIDA line. Also, Firken & Flyer at the BC Connector uses the existing sanitary main in the old C Pier, to flow to the Terminal Curbside. A vent stack in the former MAA Operations area washroom was used to discharge the Firken & Flyer restaurant into the existing sanitary main that discharges all of our C Pier.

Plumbing system installation shall conform to the latest version of the MDOT MAA Planning and Engineering Guidelines and Standards (PEGS) Manual. Link to copy: <https://public.airportal.maa.maryland.gov/pegs/#t=Home%2FHome.htm>

## D. Electrical

The goal of the project is to identify the spare capacity available in the electrical substations in proximity to each of the concession spaces. The substations feed overlapping areas, so there is not necessarily a fixed area each substation serves, however general colored shading of the drawings show the approximate areas the substations serve. The substation locations are shown on respective level of installation and tables were created to indicate the total capacity of the substation, the existing peak demand of the substation and the calculated available capacity of the substation based on the MDOT MAA's assignment of 50% of the spare capacity to concession loads.

In order to determine the existing peak demand, the existing Schneider Electric PowerLogic web-based system was reviewed. It should be noted that the peak demand of a substation does not delineate whether the substation is single-ended from one main at the time of the peak demand. Peak demands from both mains were added together, which should be a conservative value given that the peak demands of the mains did not necessarily occur at the same time. It is assumed the capacity of the substation is based on a worse-case single-ended configuration. Finally, a number of substations do not have main meters or have meters that are not operating, therefore the upstream 15kV feeder breaker meters were reviewed. In some cases there are multiple substations without main meters that are fed off the same 15kV breaker, so the peak demands are estimated, as the load diversity between the substations could not be determined. The actual peak demands were multiplied by 125%, as per the NEC, to account for short duration and intermittent loads, since the peak demand interval for the PowerLogic system is unknown. This results in a conservative spare capacity for each substation. A majority of the peak demands occurred prior to the pandemic and any future added capacity to the substations should take into consideration the timing of the peak demands relative to reduced loads during the pandemic.

Electrical system installation shall conform to the latest version of the MDOT MAA Planning and Engineering Guidelines and Standards (PEGS) Manual. Link to copy: <https://public.airportal.maa.maryland.gov/pegs/#t=Home%2FHome.htm>

## E. Information Communications Technology (ICT) & Security Systems Availability

### 1. Introduction

As previously noted, Information Communication Technology (ICT) and Security Systems deployed at BWI Marshall Airport are typically not limited by system capacity availability but rather the Division of Airport Technology (DAT) and Office of Airport Security concessionaire use policies. Use of MDOT MAA Airport systems is limited to only MDOT MAA entities. However, ICT services are available to concessionaires operating on Airport property by agreements with other services providers operating at the Airport. These agreements are arranged by the concessionaire in conjunction with the Office of Commercial Management and any associated Shared Tenant Service offerings and agreements.

There are a number of existing service providers operating at BWI Marshall Airport. Services offered include public Wi-Fi, cable/digital television, telephony, and internet connectivity. However, all facility expansions or revisions that impact public or concessionaire spaces will now require coordination with the entities occupying the space and a single service provider, SmartCity Wireless Solutions (SmartCity) of BWI Marshall Airport. Concessionaires have the option of coordinating directly with the service provider, who will then be required to work through SmartCity, or contact SmartCity for all desired ICT services.

The MDOT MAA has entered into a 15-year agreement with SmartCity Wireless Solutions of BWI Marshall Airport to provide contracted technology services to concessionaires at BWI Marshall Airport. SmartCity Wireless Solutions is a team of technology companies providing the systems. Included in the team are:

- Slice Wireless
- AT&T: Cellular DAS (digital antenna system),
- Juniper Networks-owned Mist: AI-enabled Wi-Fi and Virtual Bluetooth Beacon technology,
- Clear Channel: video, secure sponsors and advertisers,
- NGEN: local network management support, and
- Moon Lighting Electrical Service: installation of the physical infrastructure to support the public services.

The SmartCity team will continue to evolve to meet the needs of the BWI Marshall Airport concessionaires. For convenience, each of the following systems notes both the existing service providers and the SmartCity Wireless Solutions for future development/redevelopment.

2. ICT & Security Systems

a. Infrastructure

Connectivity of systems requires use of various types of infrastructure cabling. The most prevalent cabling options include copper, fiber, and coaxial. Concessionaires at BWI Marshall Airport are required to provide infrastructure cabling and appropriately sized conduit to a point of demarcation. There are two primary types of demarcation locations. The first location is within a MDOT MAA Communication Room. Accessibility into these rooms is control via access control and limited to MDOT MAA staff with an approved need. The second type of demarcation is an interface box within the ceiling space near to the leased location. The demarcation location must be coordinated with and approved by DAT prior to any construction.

As previously noted, the concessionaire is responsible for cabling and conduit including faceplate/data outlet to the demarcation location. Contractors providing infrastructure installation to the MDOT MAA demarcation location include the following.

Redevelopment/Expansion Service Providers	Existing Service Providers
<ul style="list-style-type: none"> <li>• SmartCity Wireless Solutions (Moon Lighting Electrical Service)</li> </ul>	<ul style="list-style-type: none"> <li>• Comcast</li> </ul>

All ICT system cabling and conduit must comply with DAT PEGS Guidelines and Specifications. Conduit pathways shall be sized with a 40% fill ratio. Cabling content and

conduit size will be dependent upon the needs of the concessionaire occupying the space. Typical cabling includes all or some of the following.

- (2) 4 pair Unshielded Twisted Pair (UTP) CAT 6A Copper Cable
- (1) 6 strand Single Mode Fiber cable unless specified
- (1) RG 11 coaxial cable
- (1) E-page speaker facility
- (1) E-page shunt trip facility

MDOT MAA provides backbone cabling and pathways from the demarcation location to interface points with the external service providers.

In the event that there remains existing ICT infrastructure (cabling, conduit, slab penetrations) from a previous concession, with confirmation from MDOT MAA DAT, the new concessionaire may re-use the existing materials. However, it is the responsibility of the new concessionaire to confirm quantity, connectivity, and condition of the existing. No testing or guarantees of useability will be offered from MDOT MAA between the demarcation location and the concessionaire space.

b. Network

Connectivity of technology devices is oftentimes required to perform day-to-day business activities. Two common ways of connecting devices are via a wired Local Area Network (LAN) or a Wireless Data Network (WDN). While MDOT MAA DAT provides backbone cabling for connectivity, as noted above, no MDOT MAA provided LAN or WDN systems are available for use. Concessionaires operating at BWI Marshall Airport will need to contract through SmartCity Wireless for LAN or WDN services. All network related active and passive equipment will need to be located within the leased space of the concessionaire or as arranged by the service provider. Network procurement, configuration, maintenance, and support are the responsibility of the concessionaire.

c. Internet

Connectivity of devices to the internet requires the use of an Internet Service Provider (ISP). MDOT MAA DAT does not currently provide ISP services to concessionaires. Rather, concessionaires must individually solicit and contract an ISP for these services at BWI Marshall Airport. Currently, the following ISPs are typically used at the Airport.

Redevelopment/Expansion Service Providers	Existing Service Providers
<ul style="list-style-type: none"> <li>• SmartCity Wireless Solutions</li> </ul>	<ul style="list-style-type: none"> <li>• Verizon</li> <li>• Comcast</li> <li>• Fiberlite</li> <li>• AT&amp;T</li> <li>• Sprint</li> </ul>

Contract and service issues occurring will be addressed by the concessionaire with the ISP. Should the issue be determined to be caused by MDOT MAA infrastructure beyond the demarcation point, DAT will diagnose and repair the problem.

d. Cable Television (CATV)

Availability of Cable Television (CATV) may be desired by concessionaires for the entertainment of their patrons. MDOT MAA DAT does not currently provide cable services to concessionaires. However, concessionaires may individually solicit and contract a CATV service for their leased space at BWI Marshall Airport. The concessionaire will be responsible for the procurement, installation, and support of all devices used to display CATV. CATV services may be contracted through the following providers.

Redevelopment/Expansion Service Providers	Existing Service Providers
<ul style="list-style-type: none"> <li>SmartCity Wireless Solutions (Clear Channel)</li> </ul>	<ul style="list-style-type: none"> <li>Comcast</li> </ul>

Contract and service issues occurring will be addressed by the concessionaire with the CATV provider. Should the issue be determined to be caused by MDOT MAA infrastructure beyond the demarcation point, DAT will diagnose and repair the problem.

e. Telephony

Voice communications via a conventional (non-cellular) telephone may be desired by concessionaires. MDOT MAA DAT does not currently provide telephony services to concessionaires. Rather, concessionaires must individually solicit and contract service provider. The following providers are typically used at the Airport.

Redevelopment/Expansion Service Providers	Existing Service Providers
<ul style="list-style-type: none"> <li>SmartCity Wireless Solutions (Voice over IP service)</li> </ul>	<ul style="list-style-type: none"> <li>Verizon</li> <li>AT&amp;T</li> <li>Comcast</li> <li>Other arranged providers</li> </ul>

Contract and service issues occurring will be addressed by the concessionaire with the service provider. Should the issue be determined to be caused by MDOT MAA infrastructure beyond the demarcation point, DAT will diagnose and repair the problem.

f. Mass Notification

In the unfortunate event of an emergency, the ability to provide clear and timely direction is critically needed. The MDOT MAA Mass Notification System may be required to be extended into a concessionaire's leased space. It is the responsibility of the concessionaire to provide MDOT MAA system compatible evacuation speakers and shunts via e-Page cabling installed to the demarcation location.

Only speaker and shunts will be located in the concessionaire space. All other mass notification system equipment is housed within MDOT MAA communication rooms. System maintenance, upgrades, and support of the system is the responsibility of MDOT MAA DAT. Concessionaire is responsibly only for speakers and shunts within their leased space.

g. Security

The MDOT MAA Office of Airport Security operates various security-related systems per federal regulations and Airport security requirements. Therefore, the concessionaire and their employees will be required to apply for the appropriate designation of badge (dependent upon location of leased space) as needed to access the location of the leased space.

The MDOT MAA Controlled Access Security System (CASS) is not available for concessionaire operational purposes within leased spaces at any location within the terminal or concourses. Should there be a need to access spaces currently under the monitoring and control of the CASS system, the concessionaire will be required to coordinate with the Office of Airport Security for the assignment of access rights. Should the fit-out of a concessionaire require reconfiguration or addition of portals across the airport designated security lines, approval and coordination with the Office of Airport Security is required. The concessionaire will be responsible provide any operational control into or within the concessionaire lease space as part of the space fit-out. This may include a standalone security system, key, or cipher lock style devices.

The MDOT MAA also maintains Closed Circuit Television (CCTV) cameras throughout the Airport. These cameras are primarily for security operational purposes and should not be considered part of a surveillance system required for an individual concessionaire. Generally, video from the Digital Video Management System (DVMS) is not available to the public, including the concessionaires. Any CCTV cameras and associated recording needed for operational purposes by a concessionaire should be provided by the concessionaire as part of the space fit-out.

Provision of any concessionaire required duress buttons or burglar systems for operational purposes within leased spaces should be provided by the concessionaire as part of the space fit-out.

## F. Fire Protection (Sprinkler and Fire Alarm)

### 1. Sprinkler:

The BWI Marshall Airport Main Terminal and Concourses are classified as Ordinary Hazard, Group II and are fully sprinklered. Since the existing complex is already fully sprinklered and we do not anticipate that future concession work will be at a higher hazard, any modifications to concession spaces should not require any significant fire protection upgrades. We anticipate that the work would include modifying the sprinkler branch piping and head locations / types to match up with the concession layout and reflected ceiling plan.

The existing plans available on AirPortal contained minimal information regarding the sprinkler systems. Shop drawings of the existing sprinkler systems are not available AirPortal and have been requested from MDOT MAA. As this information becomes available the plans will be updated to include sprinkler mains.

Sprinkler system installation shall conform to the latest version of the MDOT MAA Planning and Engineering Guidelines and Standards (PEGS) Manual. Link to copy:  
<https://public.airportal.maa.maryland.gov/pegs/#t=Home%2FHome.htm>

### 2. Fire Alarm:

The primary fire alarm system serving BWI Marshall Airport is the Honeywell EBI (Enterprise Building Integration) System. The signals report to a Honeywell EBI Graphics System located in the BWI Marshall Airport Dispatch Center. The Fire Alarm Panel locations are noted on the electrical plan sheets. The available capacity of the fire alarm systems as of August 2021 is detailed in the drawings and is based on information provided by Honeywell. It appears there is more than sufficient capacity in the fire alarm systems for concession additions or renovations.

The following is a summary of the FAP locations and types:

Panel Type	Panel Location
XLS3000	Pier A \ Elect Rm-A153
XLS3000	Term A-B \ Pier A - Fire Cmnd-AT045
XLS1000	Pier B Lwr Lvl Electric Rm-B105
XLS1000	Pier Bx Lwr Lvl Fire Cmnd Rm-B145
XLS1000	Pier C Lwr Lvl Fire - Mech Rm-C141 C9
XLS1000	South Terminal - Fire Cmnd Rm-ST105
XLS1000	MDOT MAA-OPS Lvl 3 Elect Rm-333
XLS1000	Pier Dx Lwr Lvl Elect. Sub-Dx124
XLS1000	Pier E Lwr Lvl Fire Cmnd Rm-E1802
XLS1000	Pier E Sterile Corr Fire Cmnd Rm-E2106A
XLS1000	NTE Lwr Lvl Fire Cmnd Rm-NTE196A
XLS1000	North Term Lwr Lvl Telephone Rm-NT109

Fire alarm installation shall conform to the latest version of the MDOT MAA Planning and Engineering Guidelines and Standards (PEGS) Manual. Link to copy:  
<https://public.airportal.maa.maryland.gov/pegs/#t=Home%2FHome.htm>

---

### III. APPENDICES

---

---

**Appendix A – Exhibits**

---

# Airport Overview Plans

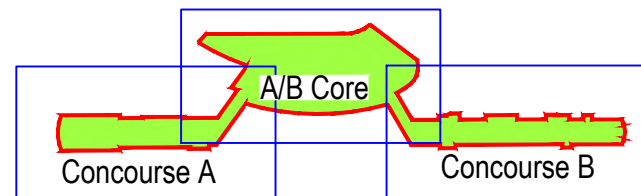

GROUND LEVEL (LEVEL 1A)

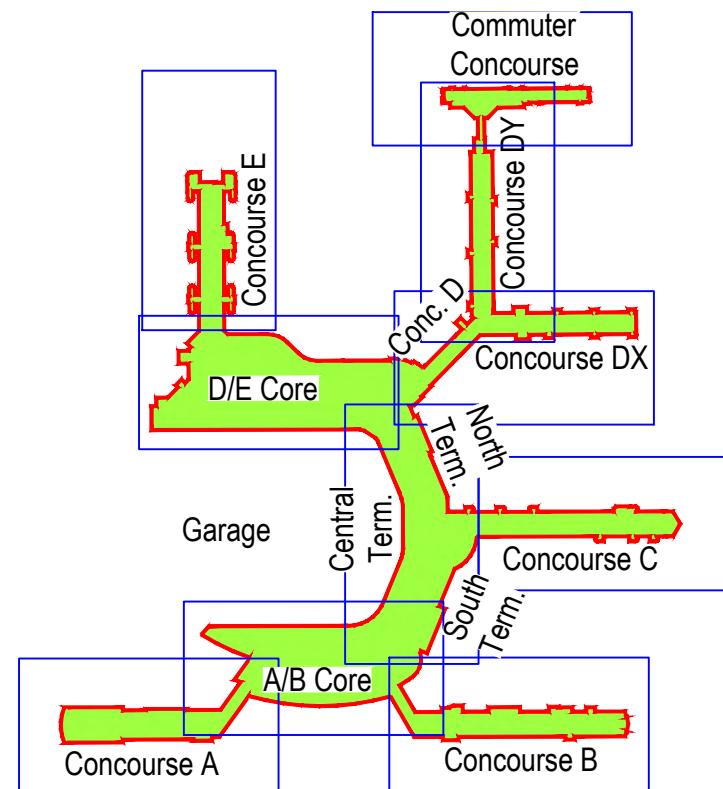

LOWER LEVEL (LEVEL 1)

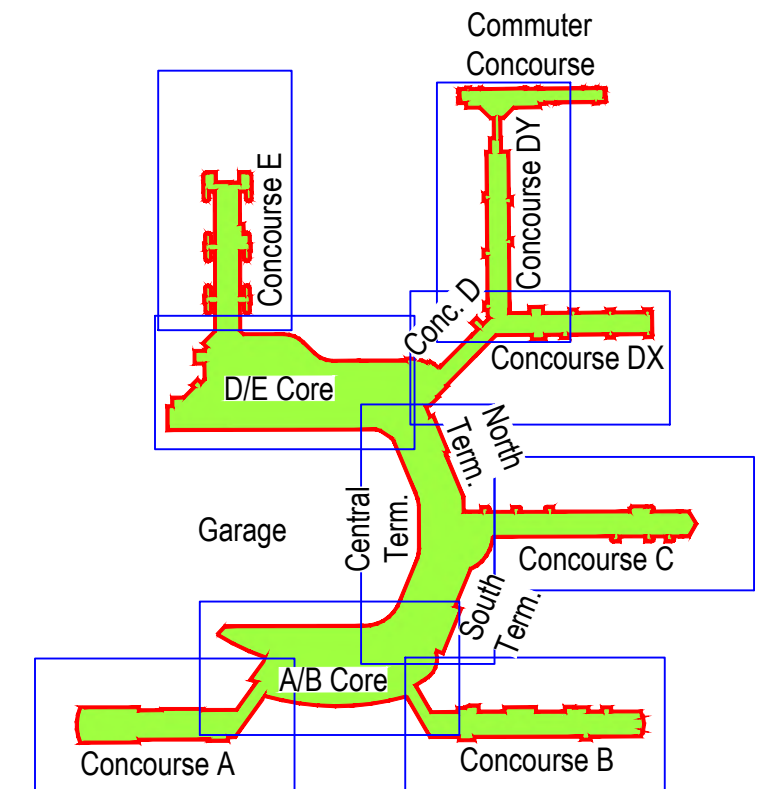

UPPER LEVEL (LEVEL 2)





# Concourse A - Ground Level (Level 1a)

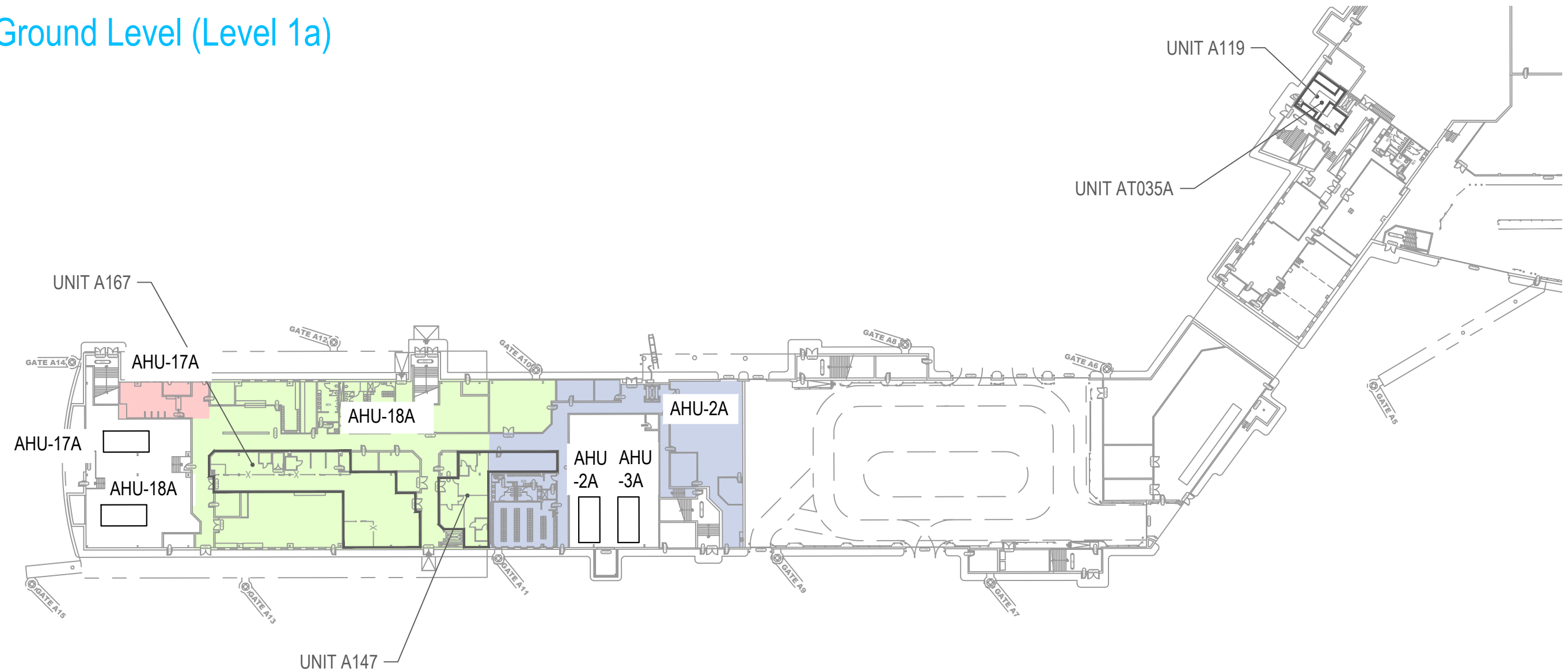

## Concession Category

- |   |                    |   |                |
|---|--------------------|---|----------------|
|  | Food Service       |  | Services       |
|  | Convenience Retail |  | Support Space  |
|  | Specialty Retail   |  | MAA Controlled |
|  | Vending            |   |                |



SCALE: 1/64" = 1'-0"

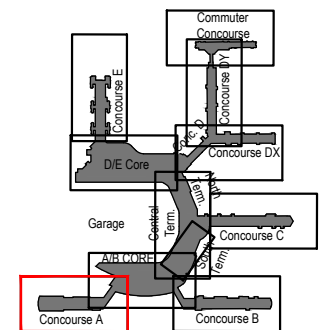

Key Plan: Airport



# A/B Core - Ground Level (Level 1a)

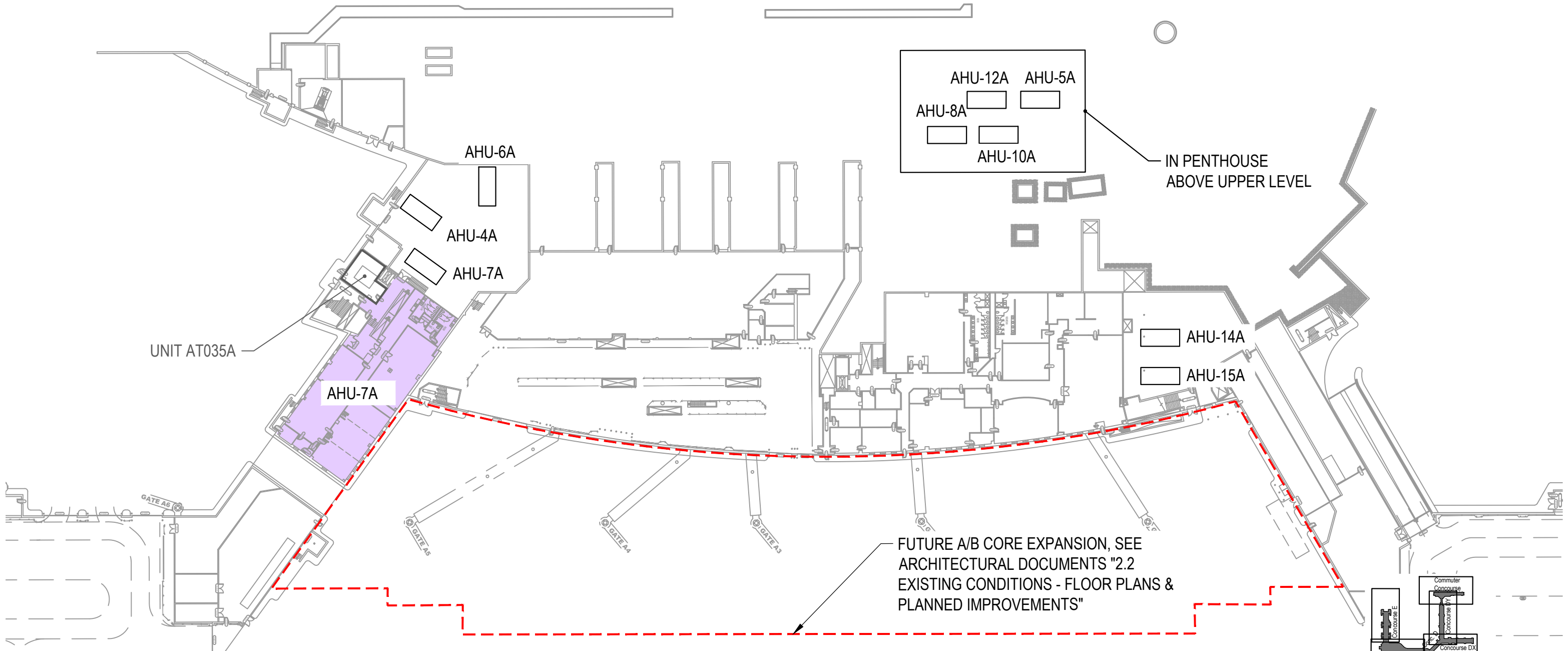

**Concession Category**

- |   |                    |   |                |
|---|--------------------|---|----------------|
|  | Food Service       |  | Services       |
|  | Convenience Retail |  | Support Space  |
|  | Specialty Retail   |  | MAA Controlled |
|  | Vending            |   |                |



SCALE: 1/64" = 1'-0"

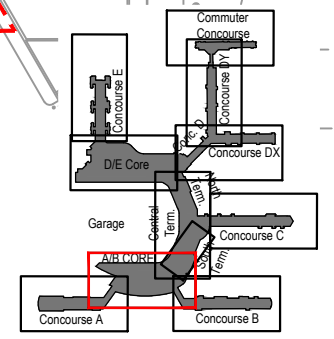

Key Plan: Airport

# Concourse B - Ground Level (Level 1a)

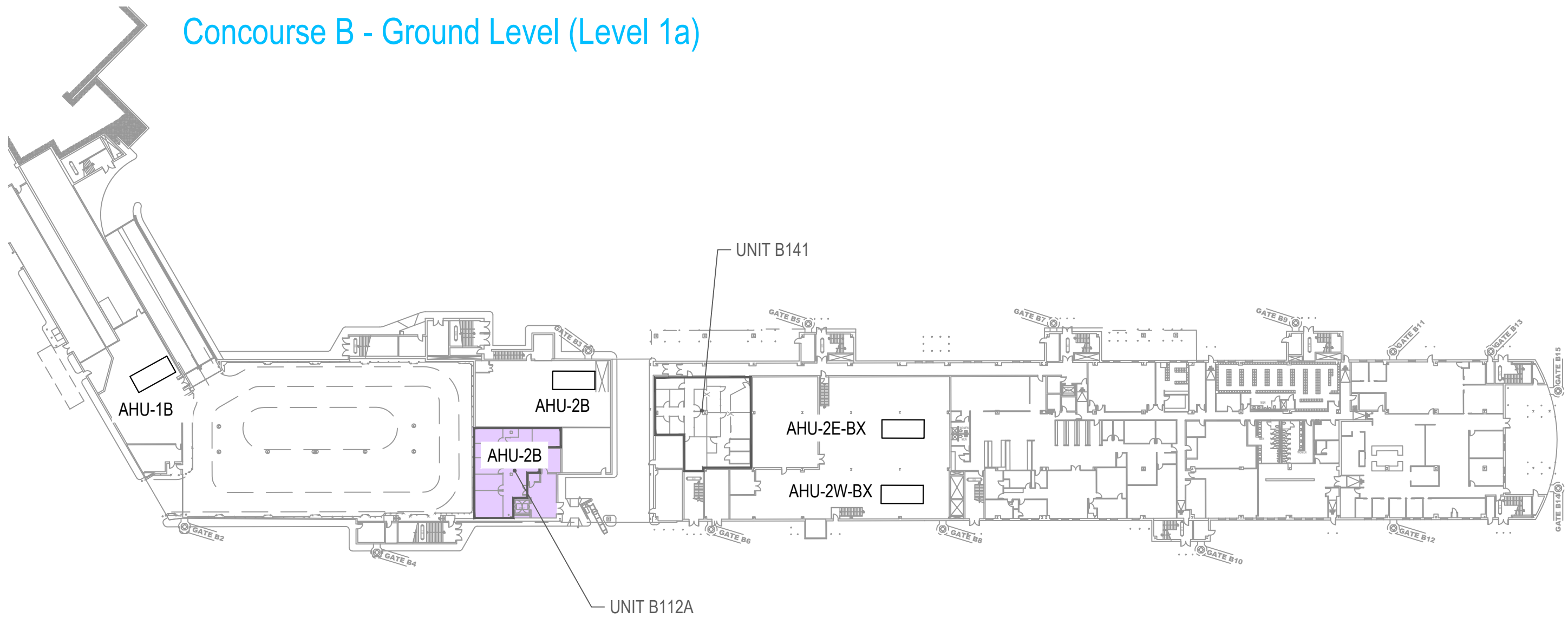

### Concession Category

- |   |                    |   |                |
|---|--------------------|---|----------------|
|  | Food Service       |  | Services       |
|  | Convenience Retail |  | Support Space  |
|  | Specialty Retail   |  | MAA Controlled |
|  | Vending            |   |                |



SCALE: 1/64" = 1'-0"

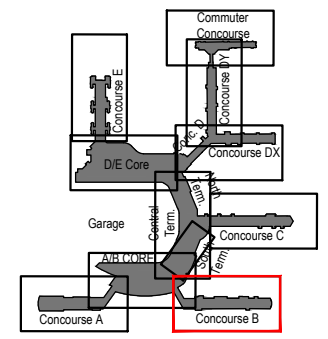

Key Plan: Airport

# A/B Core - Lower Level (Level 1)

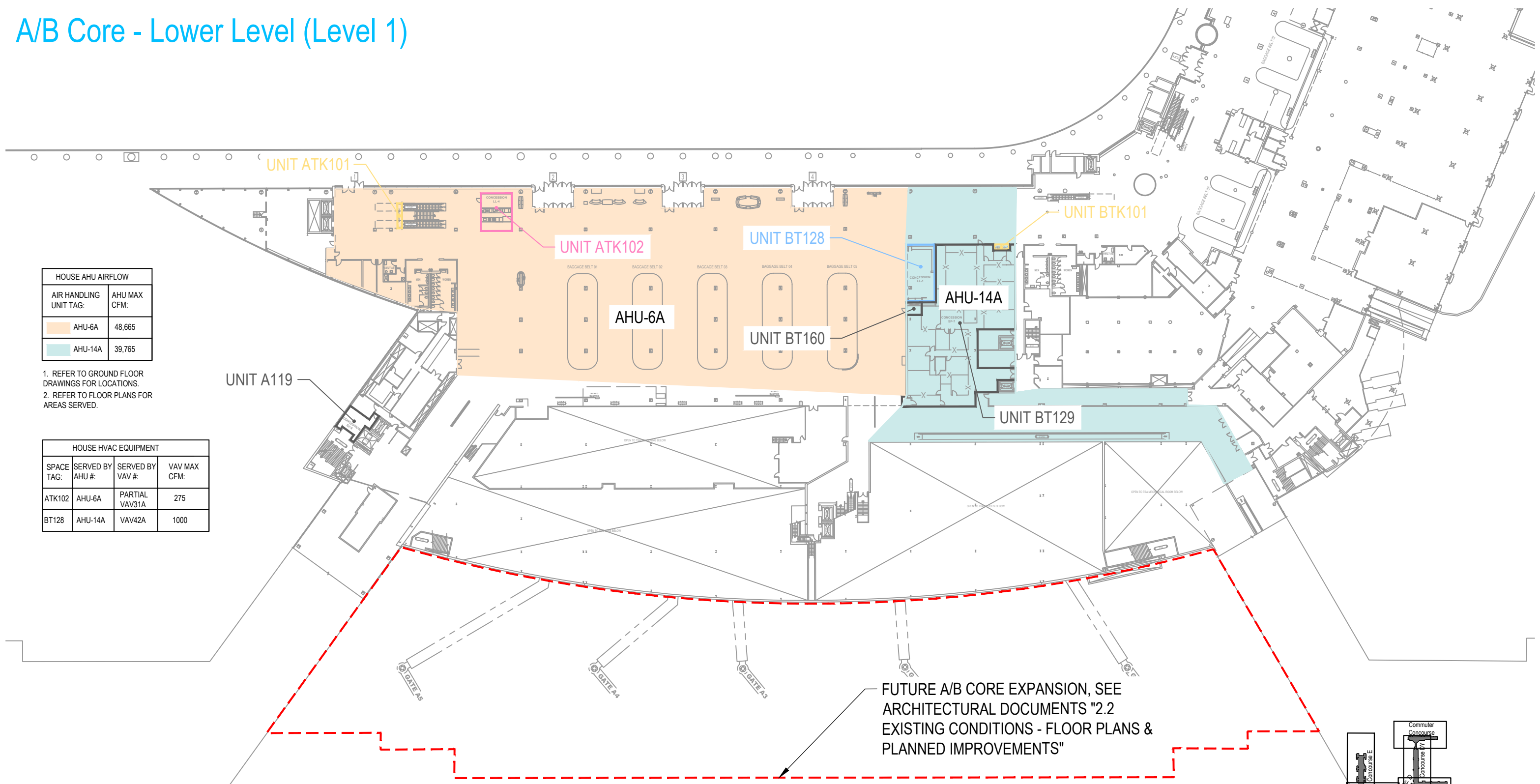

HOUSE AHU AIRFLOW	
AIR HANDLING UNIT TAG:	AHU MAX CFM:
AHU-6A	48,665
AHU-14A	39,765

1. REFER TO GROUND FLOOR DRAWINGS FOR LOCATIONS.
2. REFER TO FLOOR PLANS FOR AREAS SERVED.

HOUSE HVAC EQUIPMENT			
SPACE TAG:	SERVED BY AHU #:	SERVED BY VAV #:	VAV MAX CFM:
ATK102	AHU-6A	PARTIAL VAV31A	275
BT128	AHU-14A	VAV42A	1000

### Concession Category

- Food Service
- Convenience Retail
- Specialty Retail
- Vending
- Services
- Support Space
- MAA Controlled

FUTURE A/B CORE EXPANSION, SEE ARCHITECTURAL DOCUMENTS "2.2 EXISTING CONDITIONS - FLOOR PLANS & PLANNED IMPROVEMENTS"

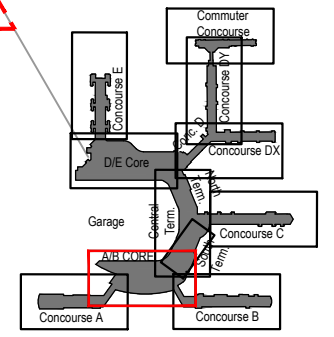

Key Plan: Airport



SCALE: 1/64" = 1'-0"



# Terminal South, Center, North - Lower Level (Level 1)

HOUSE HVAC EQUIPMENT			
SPACE TAG:	SERVED BY AHU #:	SERVED BY	MAX CFM:
STK100	AHU-1ST	REHEAT COIL	OPEN TO TERMINAL
NT120	AHU-6ST	REHEAT COIL	300

HOUSE AHU AIRFLOW	
AHU TAG:	AHU MAX CFM:
AHU-1ST	100,000
AHU-5CT	100,000
AHU-6CT	100,000

1. REFER TO GROUND FLOOR DRAWINGS FOR LOCATIONS.
2. REFER TO FLOOR PLANS FOR AREAS SERVED.

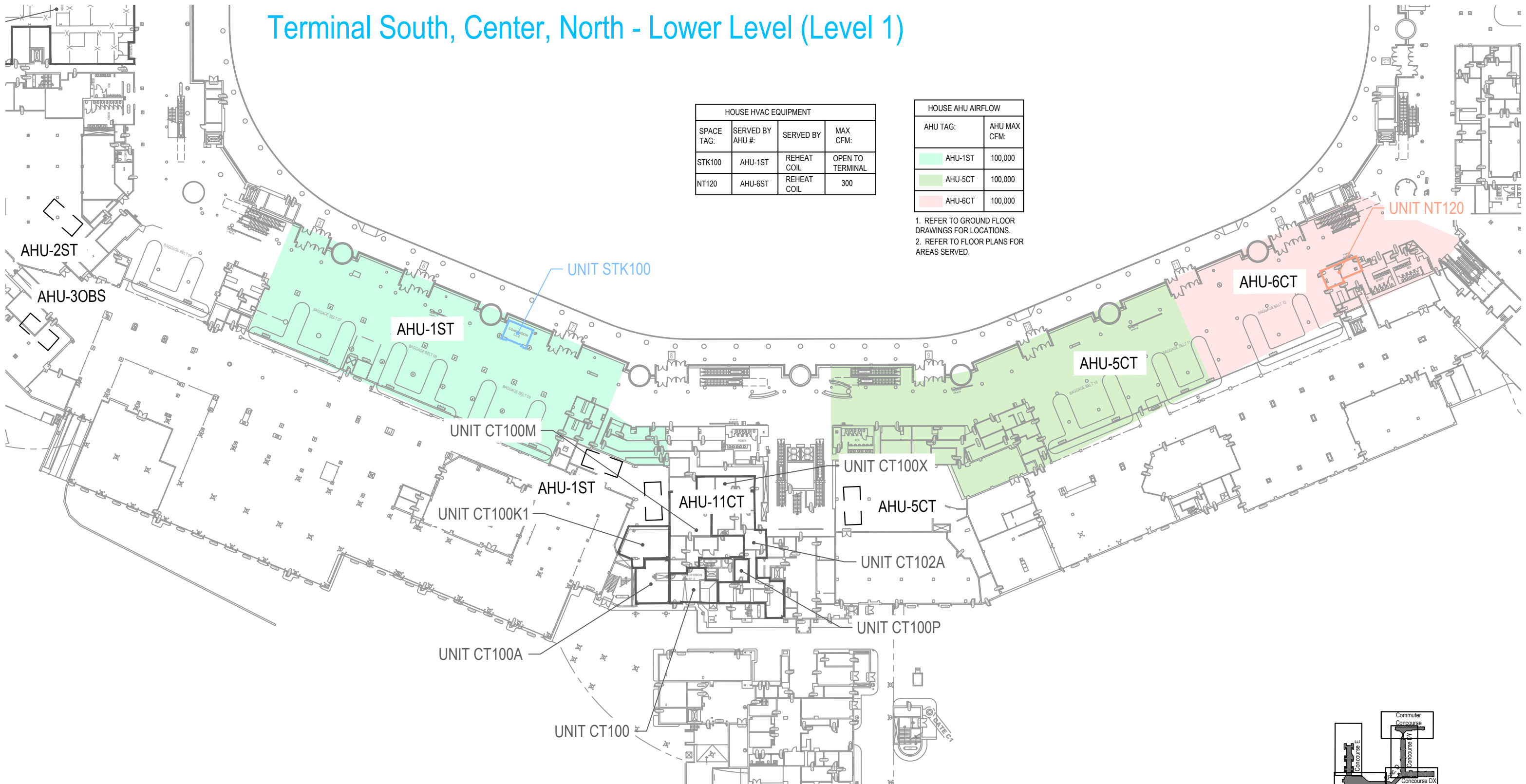

### Concession Category

- Food Service
- Convenience Retail
- Specialty Retail
- Vending
- Services
- Support Space
- MAA Controlled



SCALE: 1/64" = 1'-0"

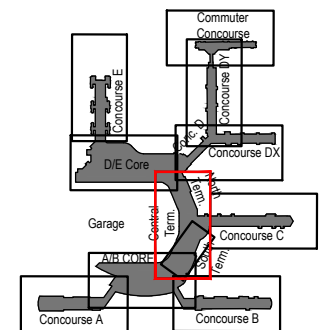

Key Plan: Airport



# Concourse C - Lower Level (Level 1)

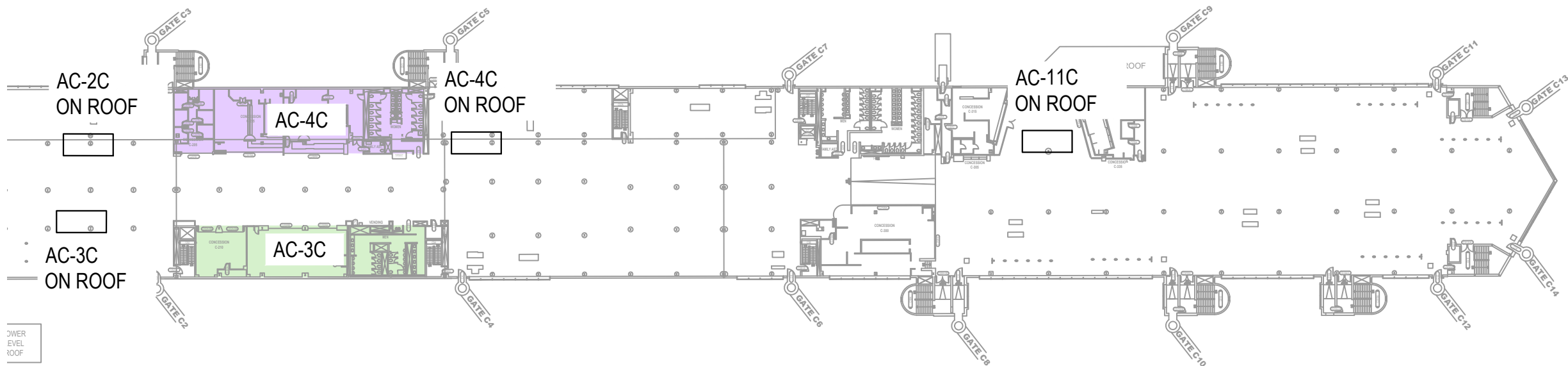

### Concession Category

- |   |                    |   |                |
|---|--------------------|---|----------------|
|  | Food Service       |  | Services       |
|  | Convenience Retail |  | Support Space  |
|  | Specialty Retail   |  | MAA Controlled |
|  | Vending            |   |                |



SCALE: 1/64" = 1'-0"

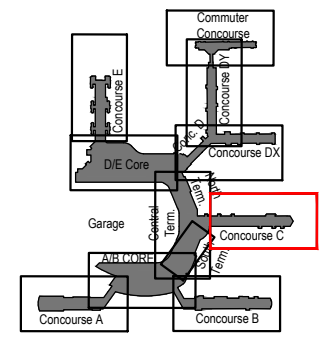

Key Plan: Airport

# Concourse D, DX - Lower Level (Level 1)

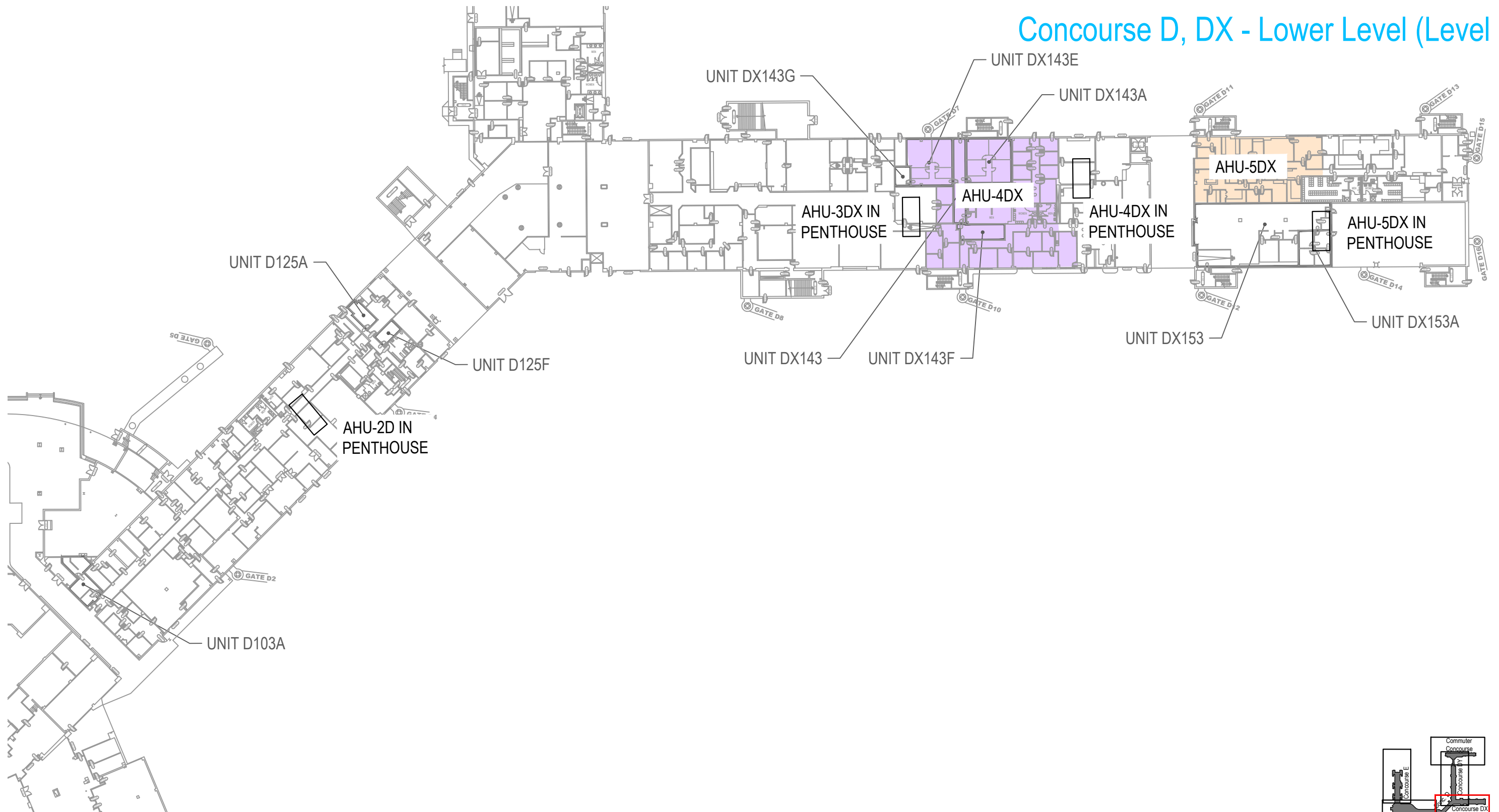

### Concession Category

- |   |                    |   |                |
|---|--------------------|---|----------------|
|  | Food Service       |  | Services       |
|  | Convenience Retail |  | Support Space  |
|  | Specialty Retail   |  | MAA Controlled |
|  | Vending            |   |                |



SCALE: 1/64" = 1'-0"

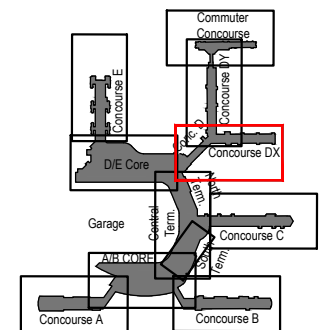

Key Plan: Airport

# Concourse DY - Lower Level (Level 1)

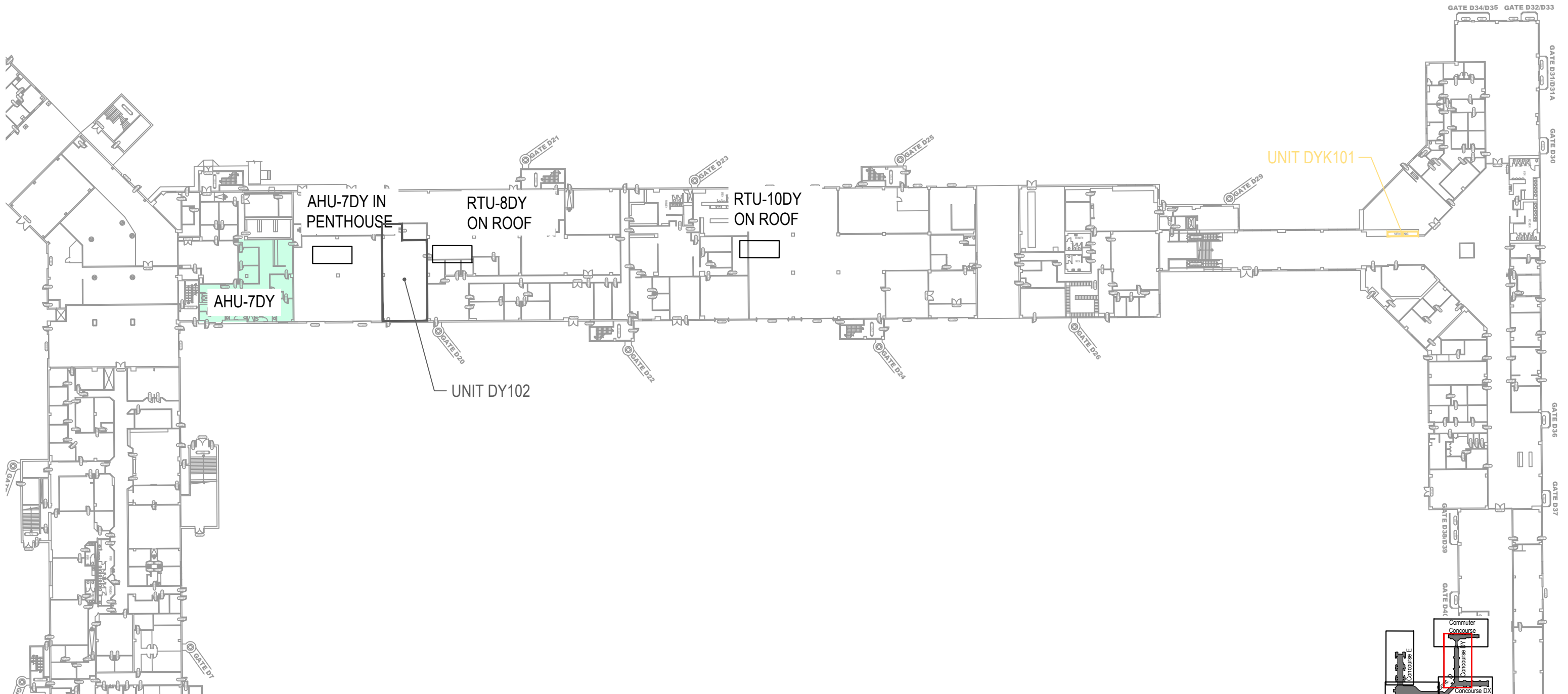

### Concession Category

- |   |                    |   |                |
|---|--------------------|---|----------------|
|  | Food Service       |  | Services       |
|  | Convenience Retail |  | Support Space  |
|  | Specialty Retail   |  | MAA Controlled |
|  | Vending            |   |                |



SCALE: 1/64" = 1'-0"

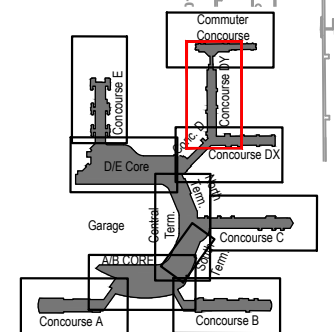

# Commuter Concourse D - Lower Level (Level 1)

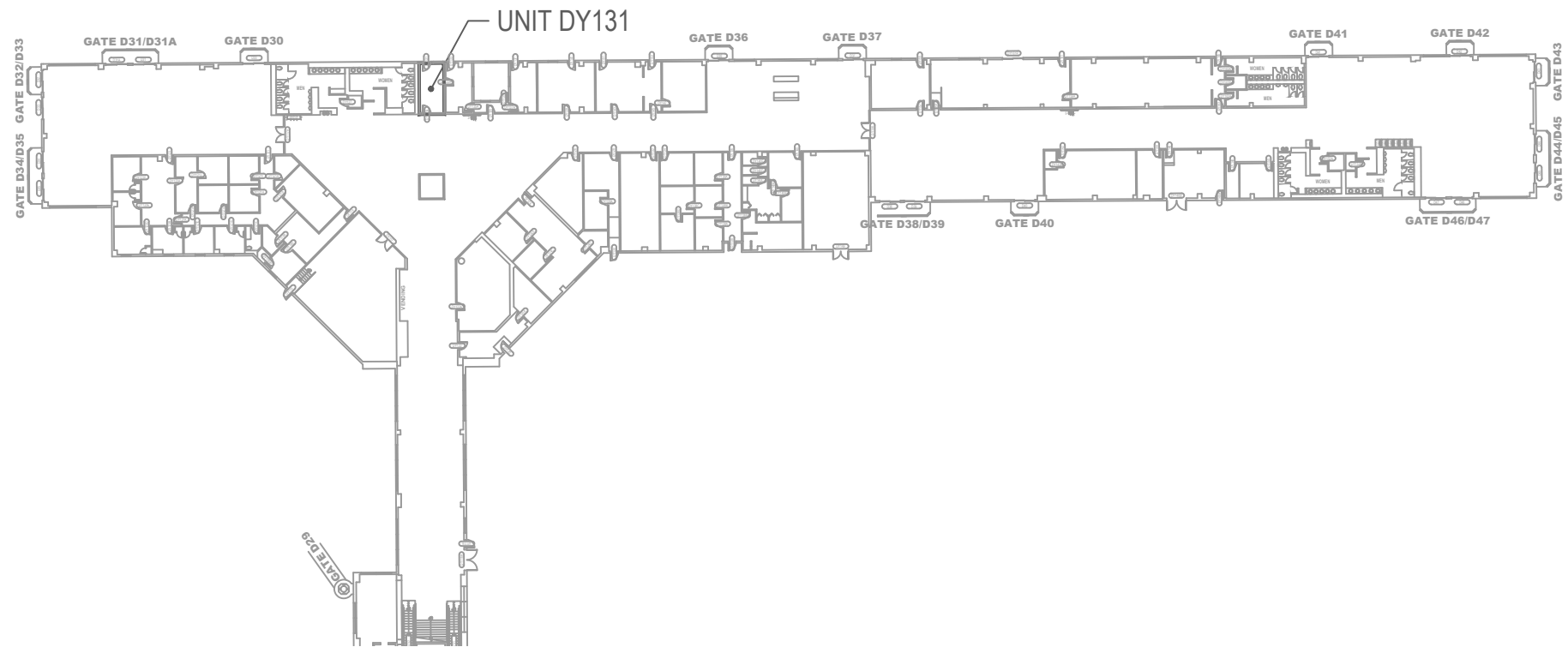

## Concession Category

- |   |                    |   |                |
|---|--------------------|---|----------------|
|  | Food Service       |  | Services       |
|  | Convenience Retail |  | Support Space  |
|  | Specialty Retail   |  | MAA Controlled |
|  | Vending            |   |                |



SCALE: 1/64" = 1'-0"

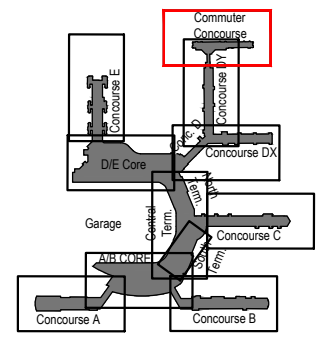

Key Plan: Airport



# D/E Core - Lower Level (Level 1)

HOUSE AHU AIRFLOW	
AIR HANDLING UNIT TAG:	AHU MAX CFM:
AHU-1E	40,000
AHU-13E	40,400
AHU-7NTX	50,000

1. REFER TO GROUND FLOOR DRAWINGS FOR LOCATIONS.
2. REFER TO FLOOR PLANS FOR AREAS SERVED.

HOUSE HVAC EQUIPMENT			
SPACE TAG:	SERVED BY AHU #:	SERVED BY VAV #:	VAV MAX CFM:
NTEK103	AHU-7NTX	NONE	OPEN TO TERMINAL
EK108	AHU-13E	NONE	OPEN TO TERMINAL
EK105	AHU-1E	NONE	OPEN TO TERMINAL

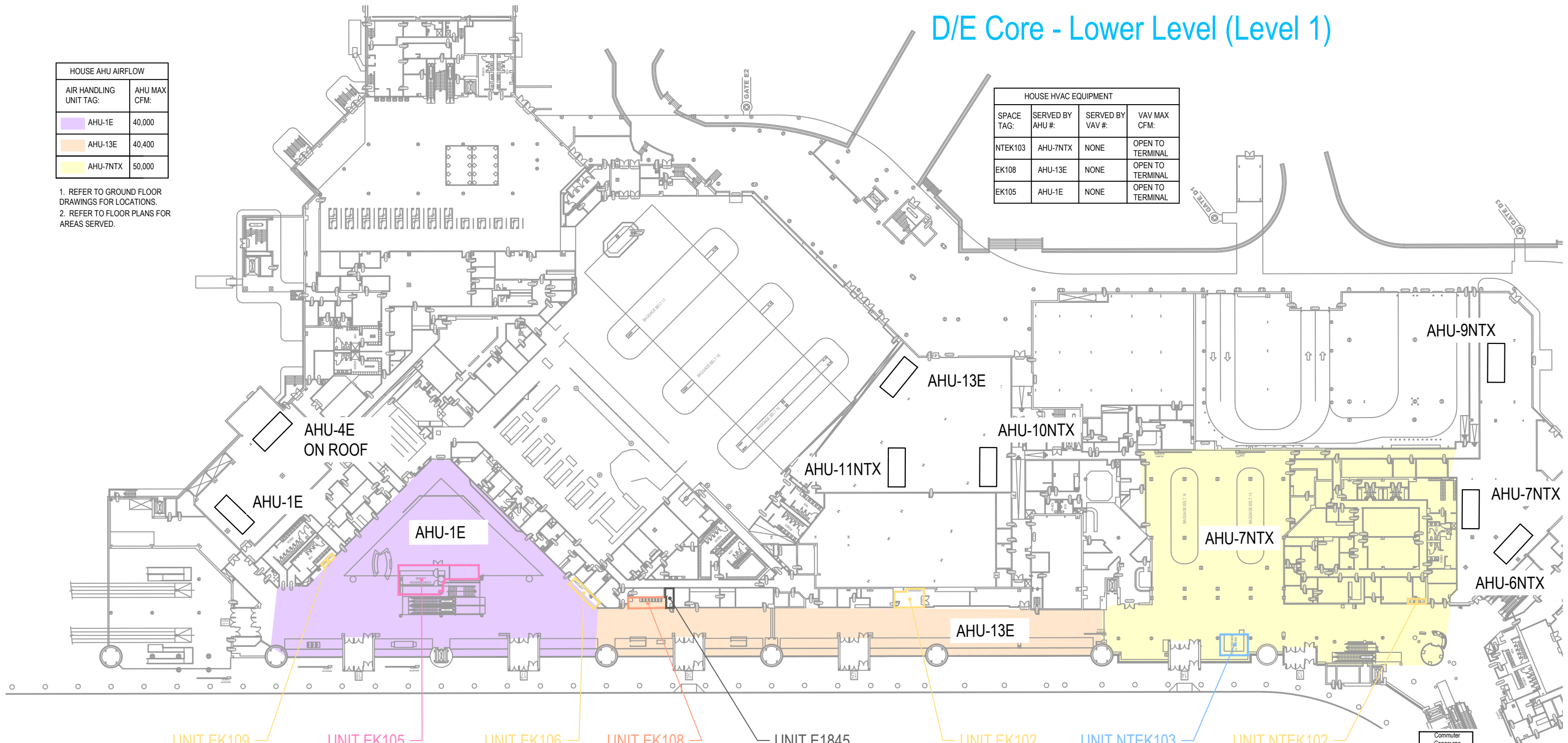

### Concession Category

- Food Service
- Convenience Retail
- Specialty Retail
- Vending
- Services
- Support Space
- MAA Controlled



SCALE: 1/64" = 1'-0"

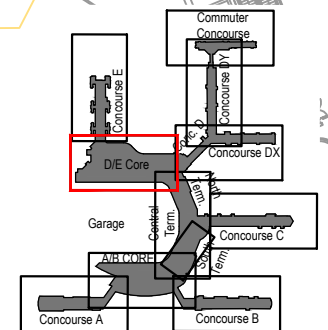

Key Plan: Airport

# Concourse E - Lower Level (Level 1)

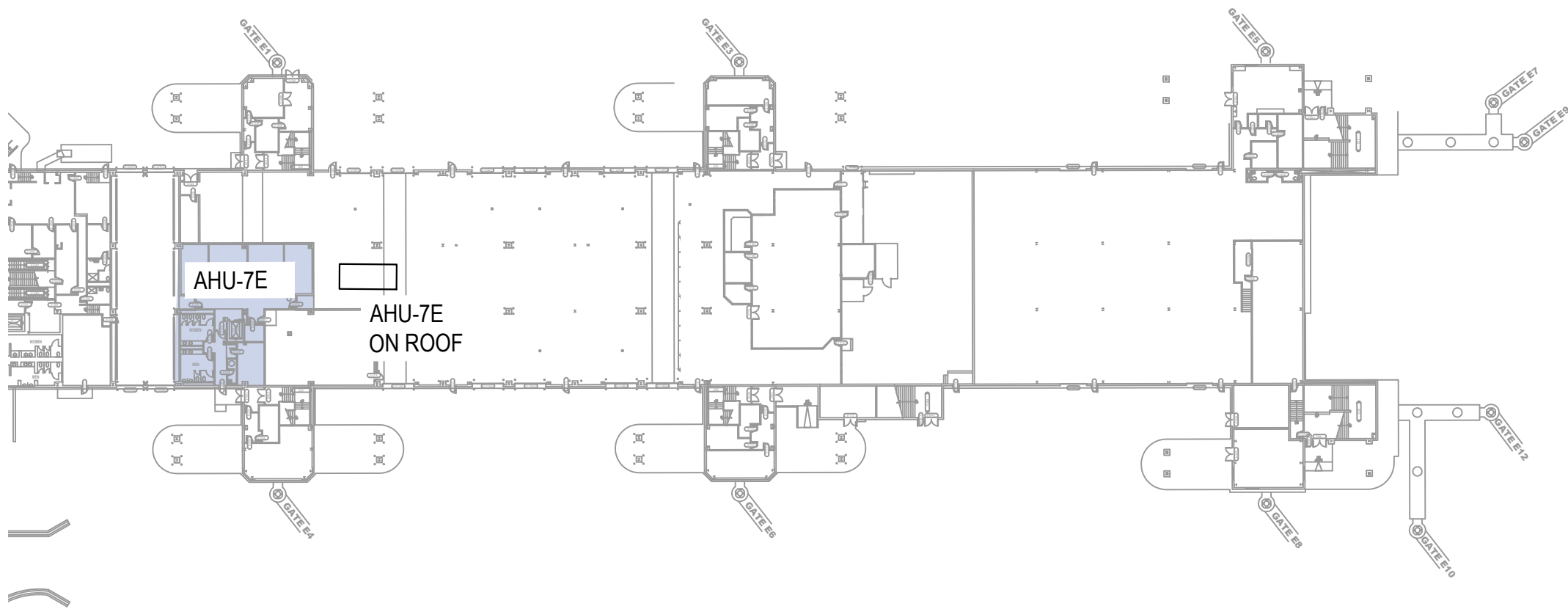

ITE E2

### Concession Category

- |   |                    |   |                |
|---|--------------------|---|----------------|
|  | Food Service       |  | Services       |
|  | Convenience Retail |  | Support Space  |
|  | Specialty Retail   |  | MAA Controlled |
|  | Vending            |   |                |



SCALE: 1/64" = 1'-0"

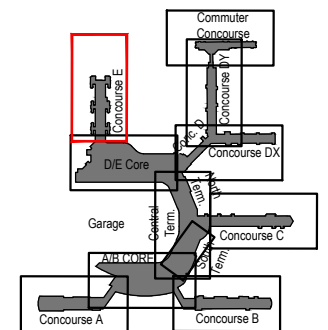

Key Plan: Airport

# Concourse A - Upper Level (Level 2)

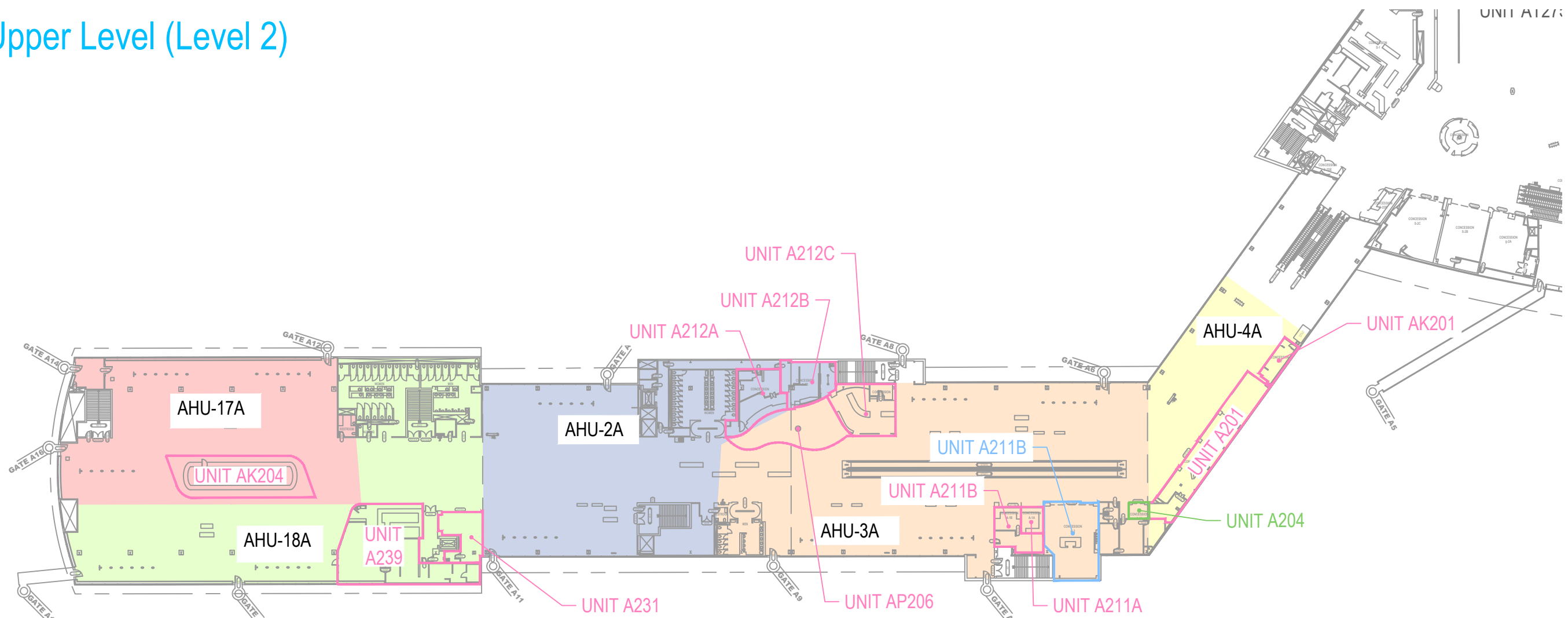

HOUSE HVAC EQUIPMENT			
SPACE TAG:	SERVED BY AHU #:	SERVED BY VAV #:	VAV MAX CFM:
AK204	AHU-17A	MULTIPLE	OPEN TO CONCOURSE
A239	AHU-18A	VAV18.17A	2000
A239	AHU-18A	VAV18.30A	2000
A231	AHU-18A	VAV18.19A	860
A212A	AHU-2A	VAV174A	400
A212A	AHU-2A	VAV179A	400
A212B	AHU-2A	VAV168A	1200
A212C	AHU-3A	PARTIAL VAV17A	1200
AP206	AHU-3A	PARTIAL VAV17A	2400
A211A&A211B	AHU-3A	VAV10A	1480
A211B	AHU-3A	VAV14A	1600
A204	AHU-3A	VAV21A	375
A201	AHU-4A	VAV22A	4800
AK201	AHU-4A	PARTIAL VAV25A	OPEN TO CONCOURSE

HOUSE AHU AIRFLOW	
AIR HANDLING UNIT TAG:	AHU MAX CFM:
AHU-2A	36,080
AHU-3A	38,765
AHU-4A	27,600
AHU-17A	30,275
AHU-18A	34,000

1. REFER TO GROUND FLOOR DRAWINGS FOR LOCATIONS.  
2. REFER TO FLOOR PLANS FOR AREAS SERVED.

TENANT HVAC EQUIPMENT			
SPACE TAG:	EQUIPMENT TYPE:	EQUIPMENT TAG#:	CFM OR TONNAGE:
A239	MAKEUP AIR UNIT	MAU1	4165 CFM
A239	DUCTLESS SPLIT	N/A	3 TONS
A212A	DUCTLESS SPLIT	N/A	1.5 TONS
A212A	SUPPLY FAN	SF1	2515 CFM
A212B	DUCTLESS SPLIT	N/A	1.25 TONS
A212B	DUCTLESS SPLIT	N/A	.75 TONS
A212B	DUCTLESS SPLIT	N/A	.75 TONS

1. IF A TENANT SPACE IS NOT LISTED, IT APPEARS NO SEPARATE HVAC SYSTEMS ARE PRESENT BEYOND THE HOUSE SYSTEMS.

## Concession Category

- Food Service
- Convenience Retail
- Specialty Retail
- Vending
- Services
- Support Space
- MAA Controlled



SCALE: 1/64" = 1'-0"

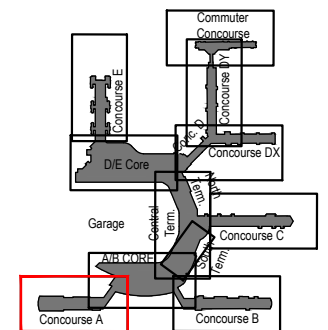

Key Plan: Airport



# A/B Core - Upper Level (Level 2)

HOUSE HVAC EQUIPMENT				HOUSE HVAC EQUIPMENT				HOUSE HVAC EQUIPMENT				HOUSE HVAC EQUIPMENT			
SPACE TAG:	SERVED BY AHU #:	SERVED BY VAV #:	VAV MAX CFM:	SPACE TAG:	SERVED BY AHU #:	SERVED BY VAV #:	VAV MAX CFM:	SPACE TAG:	SERVED BY AHU #:	SERVED BY VAV #:	VAV MAX CFM:	SPACE TAG:	SERVED BY AHU #:	SERVED BY VAV #:	VAV MAX CFM:
AT235	AHU-10A	PARTIAL VAV90A	OPEN TO CONCOURSE	ATK208	AHU-10A	PARTIAL VAV92A	OPEN TO CONCOURSE	BTK206	AHU-10A	PARTIAL VAV95A	OPEN TO CONCOURSE	BT250	AHU-14A	VAV88A	1930
AT233	AHU-10A	PARTIAL VAV90A	OPEN TO CONCOURSE	ATK210	AHU-10A	PARTIAL VAV93A	OPEN TO CONCOURSE	BTK208	AHU-10A	PARTIAL VAV95A	OPEN TO CONCOURSE	BT241	AHU-14A	VAV85A	550
ATK202	AHU-10A	PARTIAL VAV90A	OPEN TO CONCOURSE	ATK212	AHU-10A	PARTIAL VAV93A	OPEN TO CONCOURSE	BTK210	AHU-10A	PARTIAL VAV96A	OPEN TO CONCOURSE	BT251	AHU-15A	VAV181A	1600
ATK204	AHU-10A	PARTIAL VAV91A	OPEN TO CONCOURSE	BTK202	AHU-10A	PARTIAL VAV95A	OPEN TO CONCOURSE	BTK212	AHU-10A	PARTIAL VAV96A	OPEN TO CONCOURSE	BT253	AHU-15A	VAV164A	1400
ATK206	AHU-10A	PARTIAL VAV91A	OPEN TO CONCOURSE	BTK204	AHU-10A	PARTIAL VAV95A	OPEN TO CONCOURSE	BTK216	AHU-10A	PARTIAL VAV98A	OPEN TO CONCOURSE	BT255	AHU-15A	VAV163A	800

TENANT HVAC EQUIPMENT			
SPACE TAG:	EQUIPMENT TYPE:	EQUIPMENT TAG#:	CFM OR TONNAGE:
BT255	AHU	AHU-1	425 CFM
BT275B	ROOFTOP UNIT	RTU S9	2400 CFM
BT275B	MAKEUP AIR UNIT	MAU S9	1950 CFM
AT275E	MAKEUP AIR UNIT	MAU S11	1740 CFM

TENANT HVAC EQUIPMENT			
SPACE TAG:	EQUIPMENT TYPE:	EQUIPMENT TAG#:	CFM OR TONNAGE:
AT275C	MAKEUP AIR UNIT	MAU1	2820 CFM
AT275D	MAKEUP AIR UNIT	MAU S12	1760 CFM
AT275D	ROOFTOP UNIT	RTU S12	2600 CFM
BT275A	MAKEUP AIR UNIT	MAU S8	2600 CFM
BT275A	DUCTLESS SPLIT	N/A	(2)1.5 TONS
BT250	ROOFTOP UNIT	RTU S4-1	3400 CFM
BT250	MAKEUP AIR UNIT	MAU S4-1	4960 CFM
BT250	MAKEUP AIR UNIT	MAU S4-2	1275 CFM

1. IF A TENANT SPACE IS NOT LISTED, IT APPEARS NO SEPARATE HVAC SYSTEMS ARE PRESENT BEYOND THE HOUSE SYSTEMS.

HOUSE HVAC EQUIPMENT			
SPACE TAG:	SERVED BY AHU #:	SERVED BY VAV #:	VAV MAX CFM:
AT275C	AHU-5A	VAV172A	1980
AT275D	AHU-5A	VAV175A	1590
AT275E	AHU-5A	VAV167A	1920
BT275C	AHU-5A	VAV171A	500
BT275B	AHU-5A	VAV166A	1920
BT275A	AHU-5A	VAV162A	1200
AT274	AHU-5A	VAV173A	1500
BT274	AHU-5A	VAV170A	1050
AT231	AHU-7A	VAV160A	1000
AT229	AHU-7A	VAV161A	1400
AT227	AHU-7A	VAV176A	1800
AT210	AHU-8A	VAV53A	1600
AT210	AHU-8A	VAV59A	1600
AT222	AHU-8A	VAV58A	4200
BT210	AHU-12A	VAV81A	2400
BT210	AHU-12A	VAV82A	1200
BT210	AHU-12A	VAV83A	300
BT210	AHU-12A	VAV84A	300
BT250	AHU-2ST	NONE *	2000
BT254	AHU-2ST	VAV42ST	1100
BT254B	AHU-2ST	VAV30ST	600
BT254C	AHU-2ST	VAV29ST	600

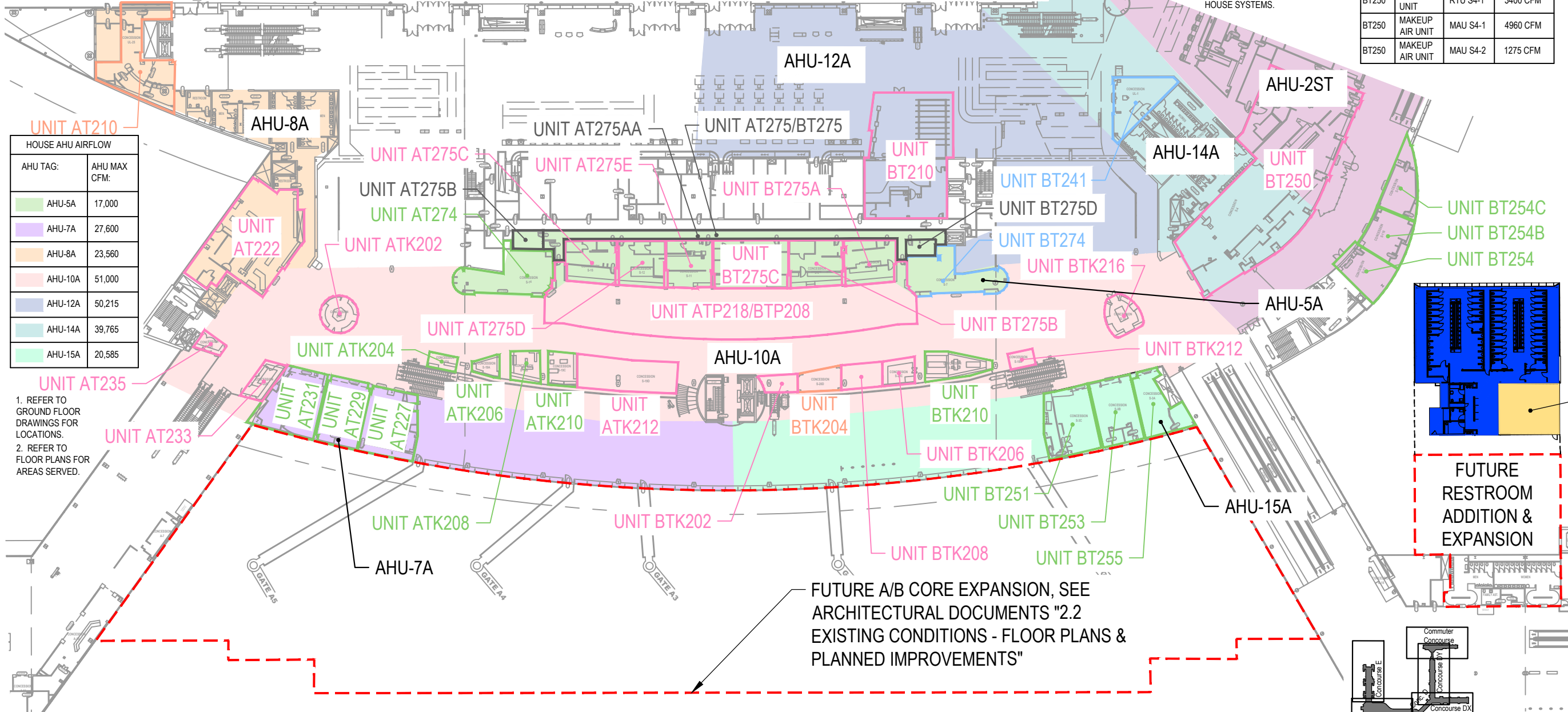

HOUSE AHU AIRFLOW	
AHU TAG:	AHU MAX CFM:
AHU-5A	17,000
AHU-7A	27,600
AHU-8A	23,560
AHU-10A	51,000
AHU-12A	50,215
AHU-14A	39,765
AHU-15A	20,585

1. REFER TO GROUND FLOOR DRAWINGS FOR LOCATIONS.  
2. REFER TO FLOOR PLANS FOR AREAS SERVED.

\* SERVED BY REHEAT COIL.

HOUSE AHU AIRFLOW	
AHU TAG:	AHU MAX CFM:
AHU-2ST	40,000

**Concession Category**

- Food Service
- Convenience Retail
- Specialty Retail
- Vending
- Services
- Support Space
- MAA Controlled

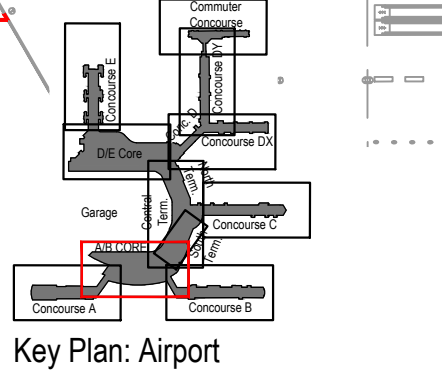
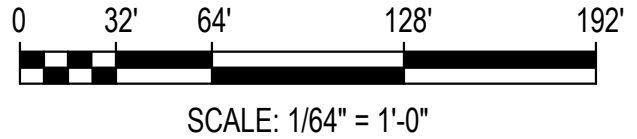

# Concourse B - Upper Level (Level 2)

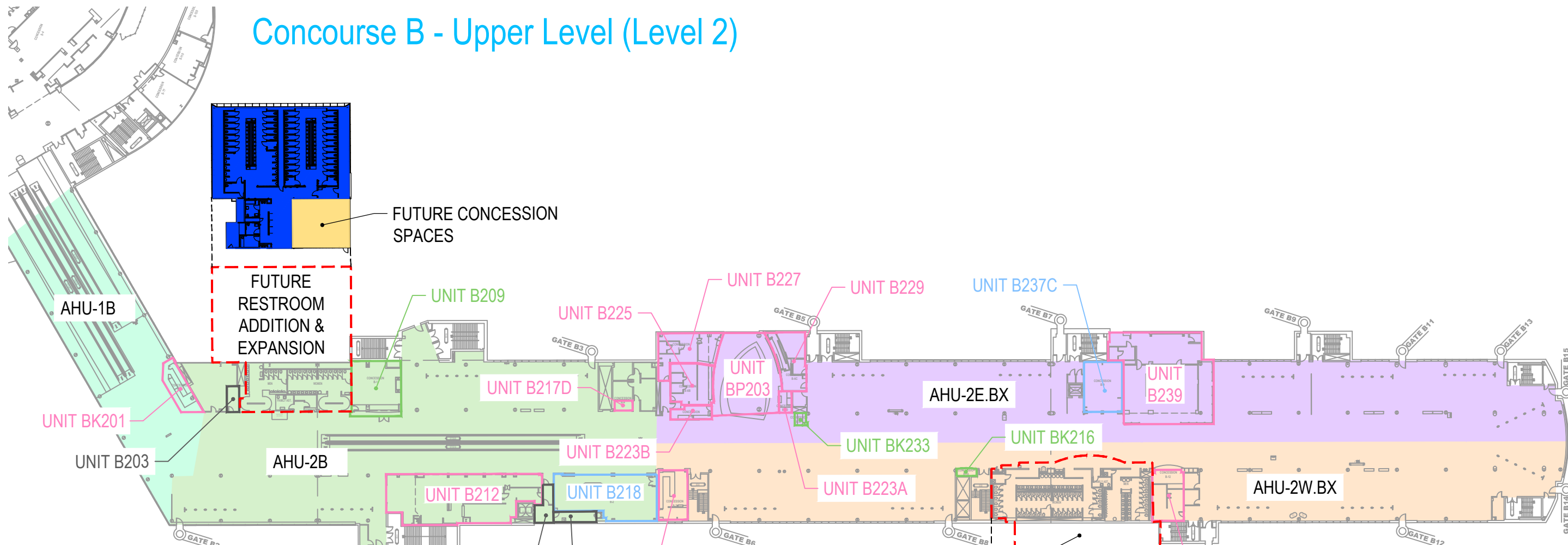

HOUSE AHU AIRFLOW	
AHU TAG:	AHU MAX CFM:
AHU-1B	17,000
AHU-2B	51,200
AHU-2E.BX	35,000
AHU-2W.BX	35,000

1. REFER TO GROUND FLOOR DRAWINGS FOR LOCATIONS.  
2. REFER TO FLOOR PLANS FOR AREAS SERVED.

HOUSE HVAC EQUIPMENT			
SPACE TAG:	SERVED BY AHU #:	SERVED BY VAV #:	VAV MAX CFM:
BK201	AHU-1B	PARTIAL VAV4B	OPEN TO CONCOURSE
B209	AHU-2B	VAV14B	1500
B212	AHU-2B	VAV10B	4800
B218	AHU-2B	VAV11B	2700
B220	AHU-2W.BX	VAV2W.1BX	600
BK216	AHU-2W.BX	PARTIAL VAV2W.7BX	OPEN TO CONCOURSE
B240	AHU-2W.BX	VAV2W.9BX	2200
B237C	AHU-2E.BX	VAV2E.12BX	1000

HOUSE HVAC EQUIPMENT			
SPACE TAG:	SERVED BY AHU #:	SERVED BY VAV #:	VAV MAX CFM:
BK233	AHU-2E.BX	PARTIAL VAV2E.4BX	OPEN TO CONCOURSE
B223A	AHU-2E.BX	PARTIAL VAV2E.4BX	OPEN TO CONCOURSE
B229	AHU-2E.BX	VAV2E.28BX	500
B227	AHU-2E.BX	VAV2E.26BX	500
B225	AHU-2E.BX	VAV2E.27BX	500
B223B	NONE	NONE	N/A
B217D	AHU-2B	PARTIAL VAV17B	OPEN TO CONCOURSE

HOUSE HVAC EQUIPMENT			
SPACE TAG:	SERVED BY AHU #:	SERVED BY VAV #:	VAV MAX CFM:
BP203	AHU-2E.BX	VAV2E.2BX	1400
BP203	AHU-2E.BX	VAV2E.3BX	1800
BP203	AHU-2E.BX	VAV2E.4BX	1600
B239	AHU-2E.BX	VAV2E.14BX	750
B239	AHU-2E.BX	VAV2E.15BX	750
B239	AHU-2E.BX	VAV2E.15ABX	1200

TENANT HVAC EQUIPMENT			
SPACE TAG:	EQUIPMENT TYPE:	EQUIPMENT TAG#:	CFM OR TONNAGE:
B223B	MAKEUP AIR UNIT	MAU B-X1-1	1137 CFM
B223B	DUCTLESS SPLIT	HP B-X1-1 & CU B-X1-1	2 TONS
B239	ROOFTOP UNIT	NONE	5500 CFM
B239	MAKEUP AIR UNIT	NONE	UNKNOWN
B227	MAKEUP AIR UNIT	MAU B6A-1	600 CFM
B227	ROOFTOP UNIT	RTU B6A-1	1950 CFM
B225	ROOFTOP UNIT	RTU B6B-1	2900 CFM
B220	ROOFTOP UNIT	NONE	1200 CFM
B229	MAKEUP AIR UNIT	MAU B6C-1	600 CFM
B229	ROOFTOP UNIT	RTU B6C-1	1950 CFM

1. IF A TENANT SPACE IS NOT LISTED, IT APPEARS NO SEPARATE HVAC SYSTEMS ARE PRESENT BEYOND THE HOUSE SYSTEMS.

### Concession Category

- Food Service
- Convenience Retail
- Specialty Retail
- Vending
- Services
- Support Space
- MAA Controlled

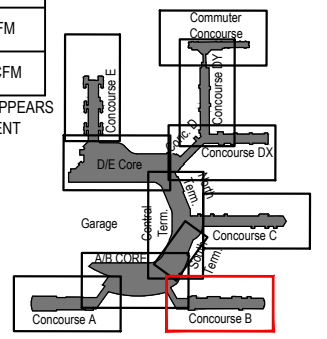

SCALE: 1/64" = 1'-0"



# Terminal South, Center, North - Upper Level (Level 2)

HOUSE HVAC EQUIPMENT			
SPACE TAG:	SERVED BY AHU #:	SERVED BY VAV #:	VAV MAX CFM:
STP207	AHU-1ST	VAV39ST	1300
STP207	AHU-1ST	VAV40ST	1300
ST205A	AHU-1ST	VAV36ST	1300
ST203	AHU-1ST	VAV37ST	1300
ST200B	AHU-1ST	VAV33ST	600

HOUSE HVAC EQUIPMENT			
SPACE TAG:	SERVED BY AHU #:	SERVED BY	MAX CFM:
CTK203	AHU-5CT	REHEAT COIL	OPEN TO TERMINAL
CT203	AHU-5CT	REHEAT COIL	300
CT201	AHU-5CT	REHEAT COIL	1200
NT243	AHU-5CT	REHEAT COIL	500
NT237	AHU-5CT	REHEAT COIL	500
NT203	AHU-6CT	REHEAT COIL	500

HOUSE HVAC EQUIPMENT			
SPACE TAG:	SERVED BY AHU #:	SERVED BY VAV #:	VAV MAX CFM:
C200M	AHU-11CT	VAV28ST	1300
C200D	AHU-11CT	VAV41ST	2900
C200D	AHU-11CT	VAV25ST	2900
C200D	AHU-11CT	VAV24ST	1100
C200E1	AHU-11CT	VAV26ST	2000
C200G	AHU-11CT	VAV26ST	300
C200F	AHU-11CT	VAV27ST	1300
C205B	AHU-2C	VAV50C	1380

HOUSE AHU AIRFLOW	
AHU TAG:	AHU MAX CFM:
AHU-1ST	100,000
AHU-5CT	100,000
AHU-11CT	30,000
AHU-2C	17,080
AHU-6CT	100,000
AHU-2ST	40,000

TENANT HVAC EQUIPMENT			
SPACE TAG:	EQUIPMENT TYPE:	EQUIPMENT TAG#:	CFM OR TONNAGE:
ST203	MAKEUP AIR UNIT	MAU	2120 CFM
ST205B	MAKEUP AIR UNIT	MAU BC-1	700 CFM
C200D	MAKEUP AIR UNIT	MAU	2570 CFM

1. IF A TENANT SPACE IS NOT LISTED, IT APPEARS NO SEPARATE HVAC SYSTEMS ARE PRESENT BEYOND THE HOUSE SYSTEMS.

- REFER TO GROUND FLOOR DRAWINGS FOR LOCATIONS.
- REFER TO FLOOR PLANS FOR AREAS SERVED.

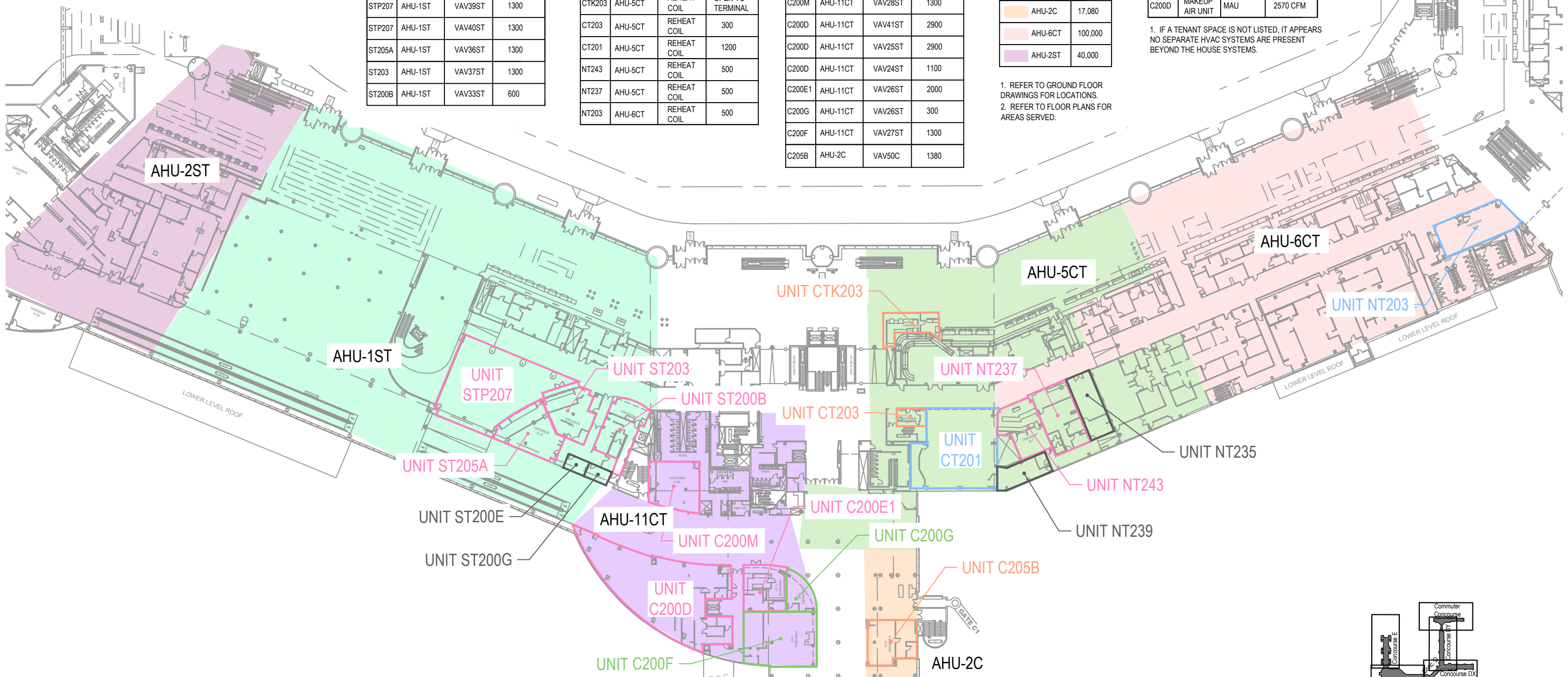

### Concession Category

- Food Service
- Convenience Retail
- Specialty Retail
- Vending
- Services
- Support Space
- MAA Controlled

0 32' 64' 128' 192'



SCALE: 1/64" = 1'-0"

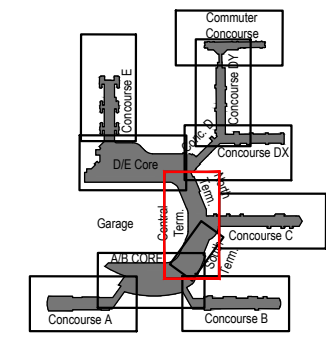

Key Plan: Airport

# Concourse C - Upper Level (Level 2)

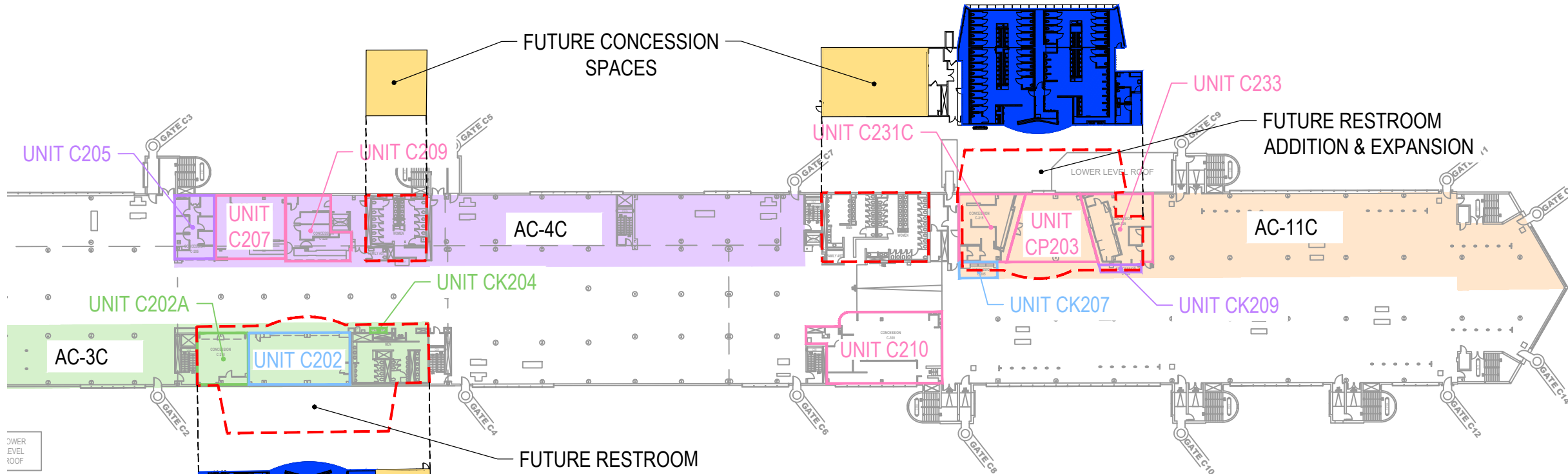

TENANT HVAC EQUIPMENT			
SPACE TAG:	EQUIPMENT TYPE:	EQUIPMENT TAG#:	CFM OR TONNAGE:
C210	MAKEUP AIR UNIT	MAU-1	2578 CFM
C210	ROOFTOP UNIT	RTU-1	2600 CFM
C210	ROOFTOP UNIT	RTU-2	2600 CFM
C207	MAKEUP AIR UNIT	MUF1	2046
C209	ROOFTOP UNIT	RTU 2-1	2620 CFM

1. IF A TENANT SPACE IS NOT LISTED, IT APPEARS NO SEPARATE HVAC SYSTEMS ARE PRESENT BEYOND THE HOUSE SYSTEMS.

HOUSE AC AIRFLOW	
AC TAG:	AC MAX CFM:
AC-3C	23,900
AC-4C	18,000
AC-11C	24,000

1. REFER TO GROUND FLOOR DRAWINGS FOR LOCATIONS.  
2. REFER TO FLOOR PLANS FOR AREAS SERVED.

HOUSE HVAC EQUIPMENT			
SPACE TAG:	SERVED BY AC #:	SERVED BY VAV #:	VAV MAX CFM:
C202A	AC-3C	VAV1C	1200
C202	AC-3C	VAV68C	2100
C210	NONE		
C205	AC-4C	VAV73C	2000
C207	AC-4C	VAV75C	1000
C209	NONE		

HOUSE HVAC EQUIPMENT			
SPACE TAG:	SERVED BY AC #:	SERVED BY VAV #:	VAV MAX CFM:
C231C	AC-11C	VAV45C	1800
C233	AC-11C	VAV43C	1150
C233	AC-11C	VAV44C	750
CP203	AC-11C	VAV40C	1050
CP203	AC-11C	VAV41C	1050
CP203	AC-11C	VAV42C	1050

HOUSE HVAC EQUIPMENT			
SPACE TAG:	SERVED BY AC #:	SERVED BY	MAX CFM:
CK207	AC-11C	REHEAT COIL	OPEN TO CONCOURSE
CK209	AC-11C	REHEAT COIL	OPEN TO CONCOURSE
CK204	AC-3C	REHEAT COIL	OPEN TO CONCOURSE

### Concession Category

- Food Service
- Convenience Retail
- Specialty Retail
- Vending
- Services
- Support Space
- MAA Controlled

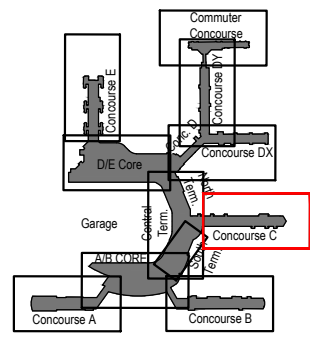
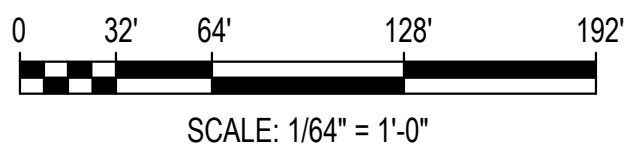

Key Plan: Airport

# Concourse D, DX - Upper Level (Level 2)

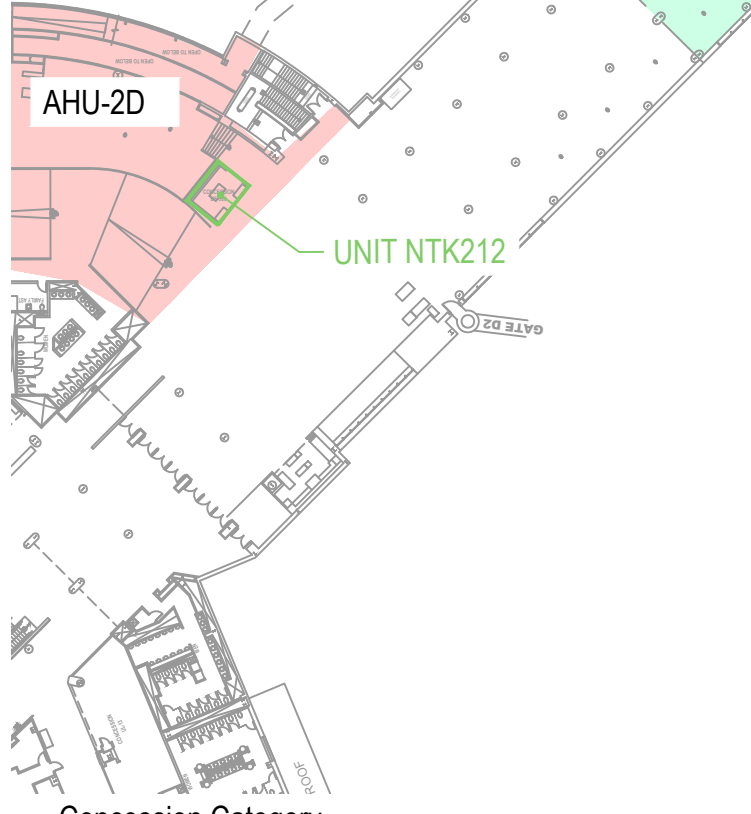
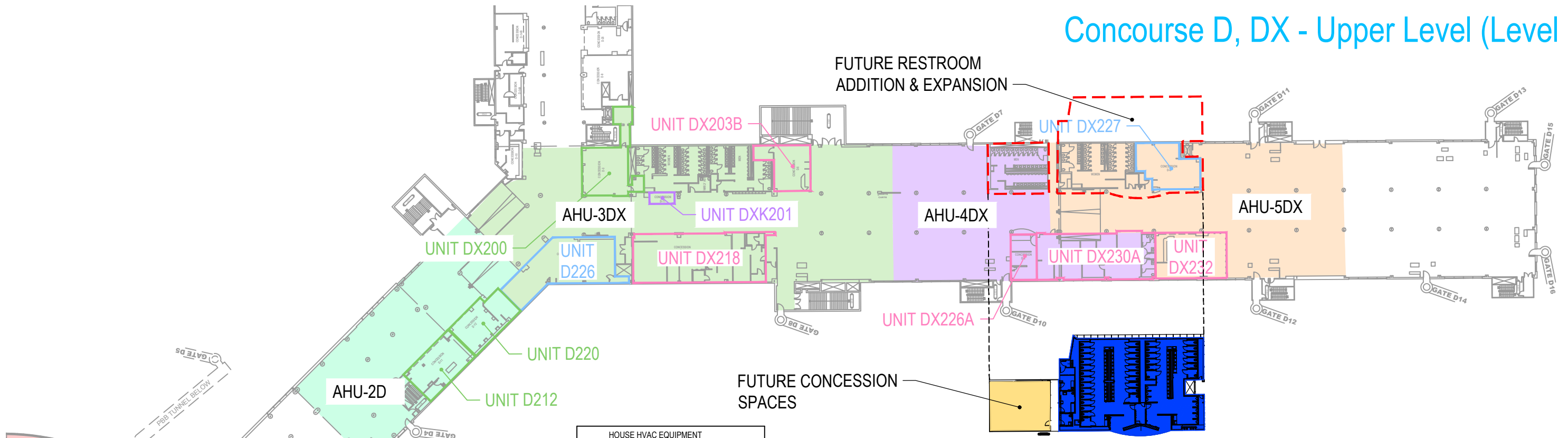

HOUSE AHU AIRFLOW	
AHU TAG:	AHU MAX CFM:
AHU-2D	25,000
AHU-3DX	20,000
AHU-4DX	22,500
AHU-5DX	23,000
AHU-10NTX	33,500

1. REFER TO GROUND FLOOR DRAWINGS FOR LOCATIONS.  
 2. REFER TO FLOOR PLANS FOR AREAS SERVED.

HOUSE HVAC EQUIPMENT			
SPACE TAG:	SERVED BY AHU #:	SERVED BY VAV #:	VAV MAX CFM:
NTK212	AHU-10NTX	PARTIAL VAV10NTX	OPEN TO CONCOURSE
D212	AHU-2D	VAV20D	1300
D220	AHU-2D	VAV50D	1500
D226	AHU-3DX	VAV26DX	1400
D226	AHU-3DX	VAV28DX	260
D226	AHU-3DX	VAV29DX	260
DX218	AHU-3DX	VAV32DX	4000
DX226A	AHU-4DX	VAV46DX	300
DX230A	AHU-4DX	VAV4.4DX	3800
DX232	AHU-5DX	VAV51DX	4800
DX227	AHU-5DX	VAV48DX	600
DX203B	AHU-3DX	VAV38DX	600
DX200	AHU-3DX	VAV30DX	600
DXK201	AHU-3DX	MULTIPLE	OPEN TO CONCOURSE

TENANT HVAC EQUIPMENT			
SPACE TAG:	EQUIPMENT TYPE:	EQUIPMENT TAG#:	CFM OR TONNAGE:
DX232	MAKEUP AIR UNIT	MAU	2400 CFM
DX232	ROOFTOP UNIT	RTU	1845 CFM
DX218	ROOFTOP UNIT	RTU 4D-1	4800 CFM
DX218	MAKEUP AIR UNIT	MAU 4D-1	1350 CFM

1. IF A TENANT SPACE IS NOT LISTED, IT APPEARS NO SEPARATE HVAC SYSTEMS ARE PRESENT BEYOND THE HOUSE SYSTEMS.

### Concession Category

- Food Service
- Convenience Retail
- Specialty Retail
- Vending
- Services
- Support Space
- MAA Controlled



SCALE: 1/64" = 1'-0"

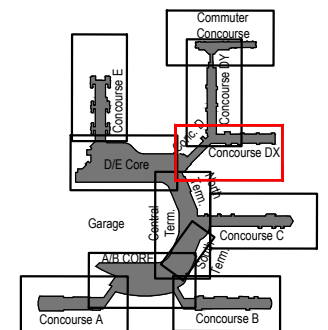

Key Plan: Airport



# Concourse DY - Upper Level (Level 2)

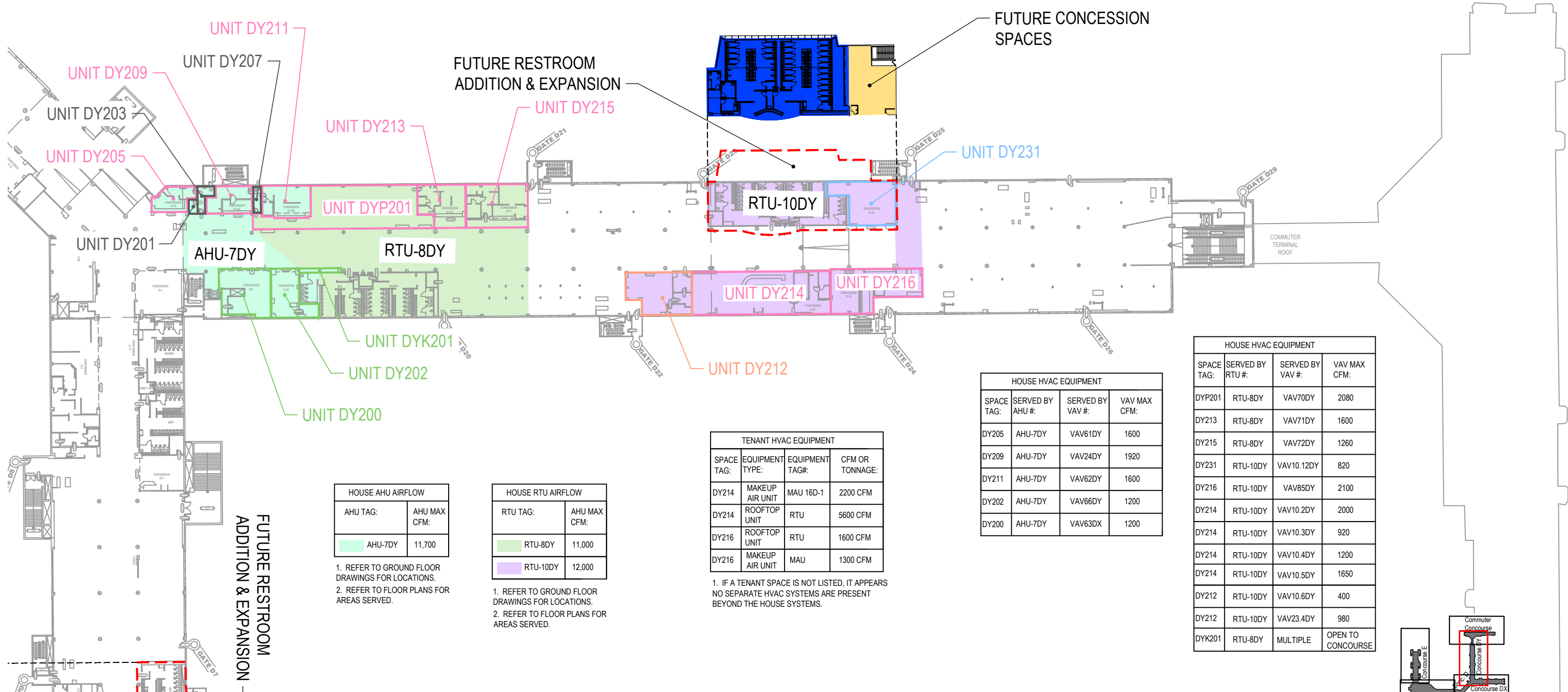

HOUSE AHU AIRFLOW	
AHU TAG:	AHU MAX CFM:
AHU-7DY	11,700

1. REFER TO GROUND FLOOR DRAWINGS FOR LOCATIONS.  
2. REFER TO FLOOR PLANS FOR AREAS SERVED.

HOUSE RTU AIRFLOW	
RTU TAG:	AHU MAX CFM:
RTU-8DY	11,000
RTU-10DY	12,000

1. REFER TO GROUND FLOOR DRAWINGS FOR LOCATIONS.  
2. REFER TO FLOOR PLANS FOR AREAS SERVED.

TENANT HVAC EQUIPMENT			
SPACE TAG:	EQUIPMENT TYPE:	EQUIPMENT TAG#:	CFM OR TONNAGE:
DY214	MAKEUP AIR UNIT	MAU 16D-1	2200 CFM
DY214	ROOFTOP UNIT	RTU	5600 CFM
DY216	ROOFTOP UNIT	RTU	1600 CFM
DY216	MAKEUP AIR UNIT	MAU	1300 CFM

1. IF A TENANT SPACE IS NOT LISTED, IT APPEARS NO SEPARATE HVAC SYSTEMS ARE PRESENT BEYOND THE HOUSE SYSTEMS.

HOUSE HVAC EQUIPMENT			
SPACE TAG:	SERVED BY AHU #:	SERVED BY VAV #:	VAV MAX CFM:
DY205	AHU-7DY	VAV61DY	1600
DY209	AHU-7DY	VAV24DY	1920
DY211	AHU-7DY	VAV62DY	1600
DY202	AHU-7DY	VAV66DY	1200
DY200	AHU-7DY	VAV63DX	1200

HOUSE HVAC EQUIPMENT			
SPACE TAG:	SERVED BY RTU #:	SERVED BY VAV #:	VAV MAX CFM:
DYP201	RTU-8DY	VAV70DY	2080
DY213	RTU-8DY	VAV71DY	1600
DY215	RTU-8DY	VAV72DY	1260
DY231	RTU-10DY	VAV10.12DY	820
DY216	RTU-10DY	VAV85DY	2100
DY214	RTU-10DY	VAV10.2DY	2000
DY214	RTU-10DY	VAV10.3DY	920
DY214	RTU-10DY	VAV10.4DY	1200
DY214	RTU-10DY	VAV10.5DY	1650
DY212	RTU-10DY	VAV10.6DY	400
DY212	RTU-10DY	VAV23.4DY	980
DYK201	RTU-8DY	MULTIPLE	OPEN TO CONCOURSE

### Concession Category

- Food Service
- Convenience Retail
- Specialty Retail
- Vending
- Services
- Support Space
- MAA Controlled



SCALE: 1/64" = 1'-0"

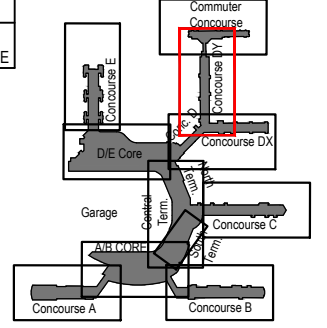
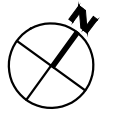

Key Plan: Airport

# D/E Core - Upper Level (Level 2)

HOUSE HVAC EQUIPMENT			
SPACE TAG:	SERVED BY AHU #:	SERVED BY VAV #:	VAV MAX CFM:
NTE202	AHU-9NTX	VAV9.18NTX	2175
NTE260A	AHU-10NTX	VAV10.8NTX	1450
NTE260B	AHU-10NTX	VAV10.9NTX	1200
NTE260C	AHU-10NTX	VAV10.22NTX	975
NTE260D	AHU-10NTX	VAV10.10NTX	1280
NTE260E	AHU-11NTX	PARTIAL VAV11.8NTX	OPEN TO CONCOURSE
EP3002	NONE	OUTDOORS	NONE
EK3010	AHU-13E	NONE *	OPEN TO TERMINAL
E3000K	AHU-7E	VAV7.29E	1300
NTE264	AHU-11NTX	VAV11.6NTX	1050

\* SERVED BY REHEAT COIL.

HOUSE AHU AIRFLOW	
AIR HANDLING UNIT TAG:	AHU MAX CFM:
AHU-7E	46,000
AHU-13E	40,400
AHU-9NTX	76,000
AHU-10NTX	33,500
AHU-11NTX	42,500

1. REFER TO GROUND FLOOR DRAWINGS FOR LOCATIONS.
2. REFER TO FLOOR PLANS FOR AREAS SERVED.

TENANT HVAC EQUIPMENT			
SPACE TAG:	EQUIPMENT TYPE:	EQUIPMENT TAG#:	CFM OR TONNAGE:
NTE260D	MAKEUP AIR UNIT	MAU DE320	2250 CFM
NTE260D	SPLIT SYSTEM	AC-1 CU-1	3 TONS
NTE202	MAKEUP AIR UNIT	MAU NTE202	2100 CFM
NTE202	SPLIT SYSTEM	FCU-1/FCU-2 HP-1	3 TONS

1. IF A TENANT SPACE IS NOT LISTED, IT APPEARS NO SEPARATE HVAC SYSTEMS ARE PRESENT BEYOND THE HOUSE SYSTEMS.

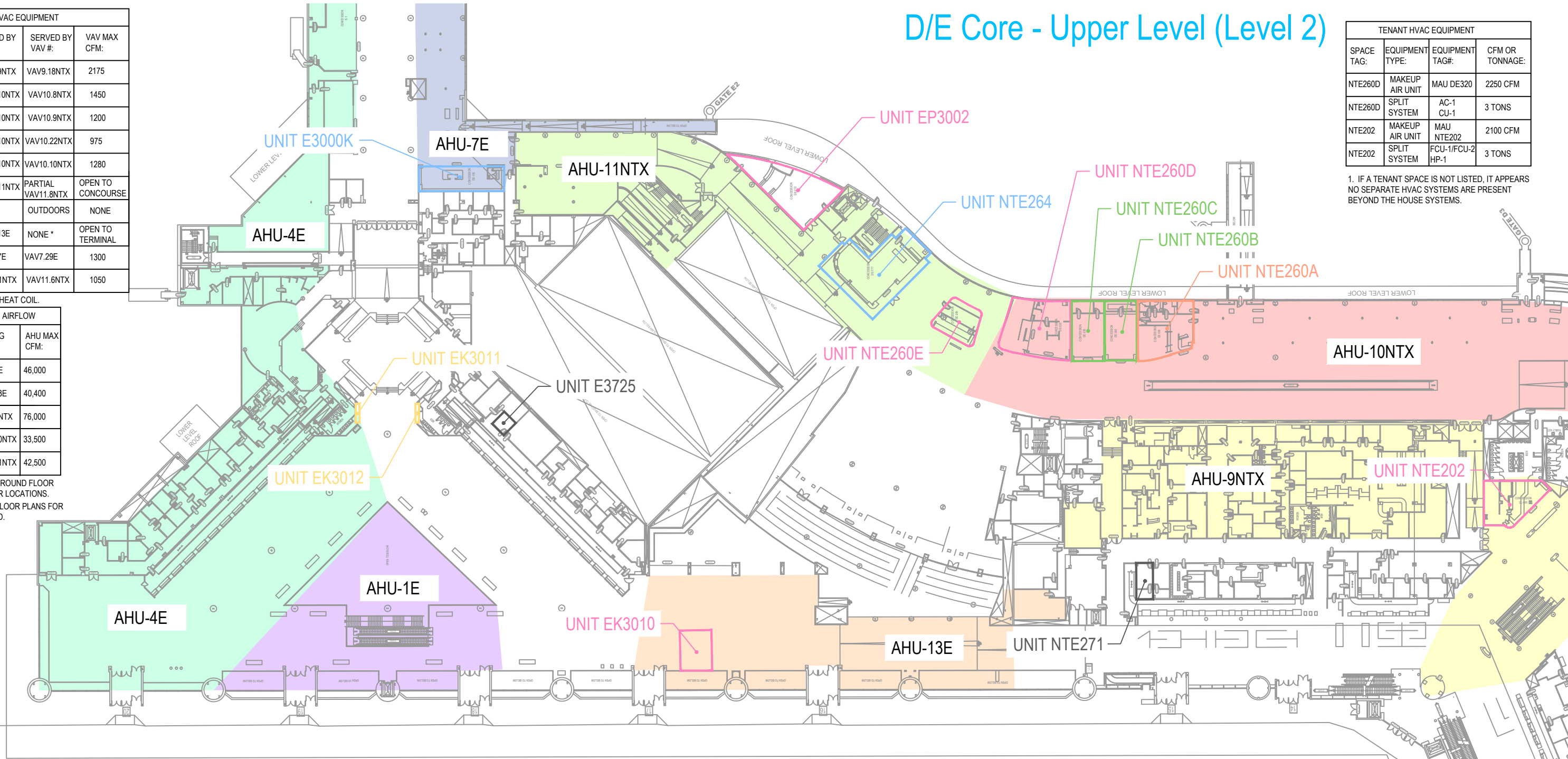

### Concession Category

- Food Service
- Convenience Retail
- Specialty Retail
- Vending
- Services
- Support Space
- MAA Controlled

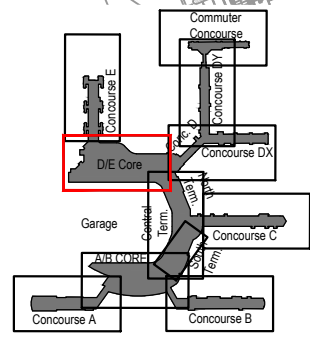

Key Plan: Airport



SCALE: 1/64" = 1'-0"

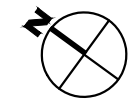

# Concourse E - Upper Level (Level 2)

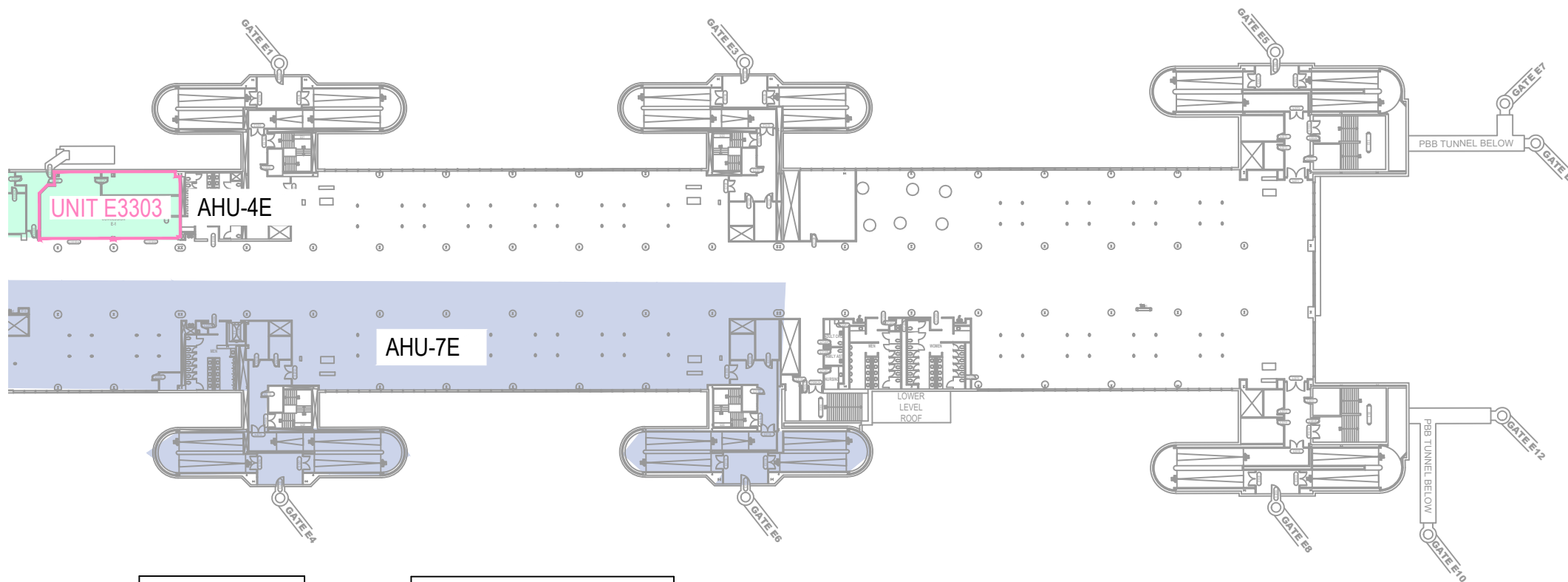

HOUSE AHU AIRFLOW	
AHU TAG:	AHU MAX CFM:
AHU-4E	27,000
AHU-7E	46,000

HOUSE HVAC EQUIPMENT			
SPACE TAG:	SERVED BY AHU #:	SERVED BY VAV #:	VAV MAX CFM:
E3303	AHU-4E	VAV4.17E	1500
E3303	AHU-4E	VAV4.17E	1500
E3303	AHU-4E	VAV4.17E	1500

1. REFER TO GROUND FLOOR DRAWINGS FOR LOCATIONS.
2. REFER TO FLOOR PLANS FOR AREAS SERVED.

## Concession Category

- Food Service
- Convenience Retail
- Specialty Retail
- Vending
- Services
- Support Space
- MAA Controlled



SCALE: 1/64" = 1'-0"

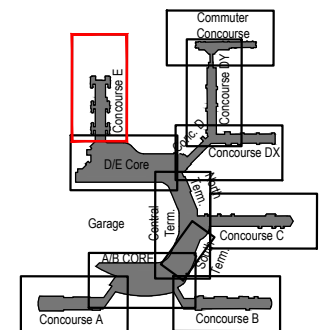
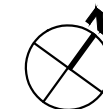

Key Plan: Airport

# Terminal Observation Gallery - Upper Level Mezzanine

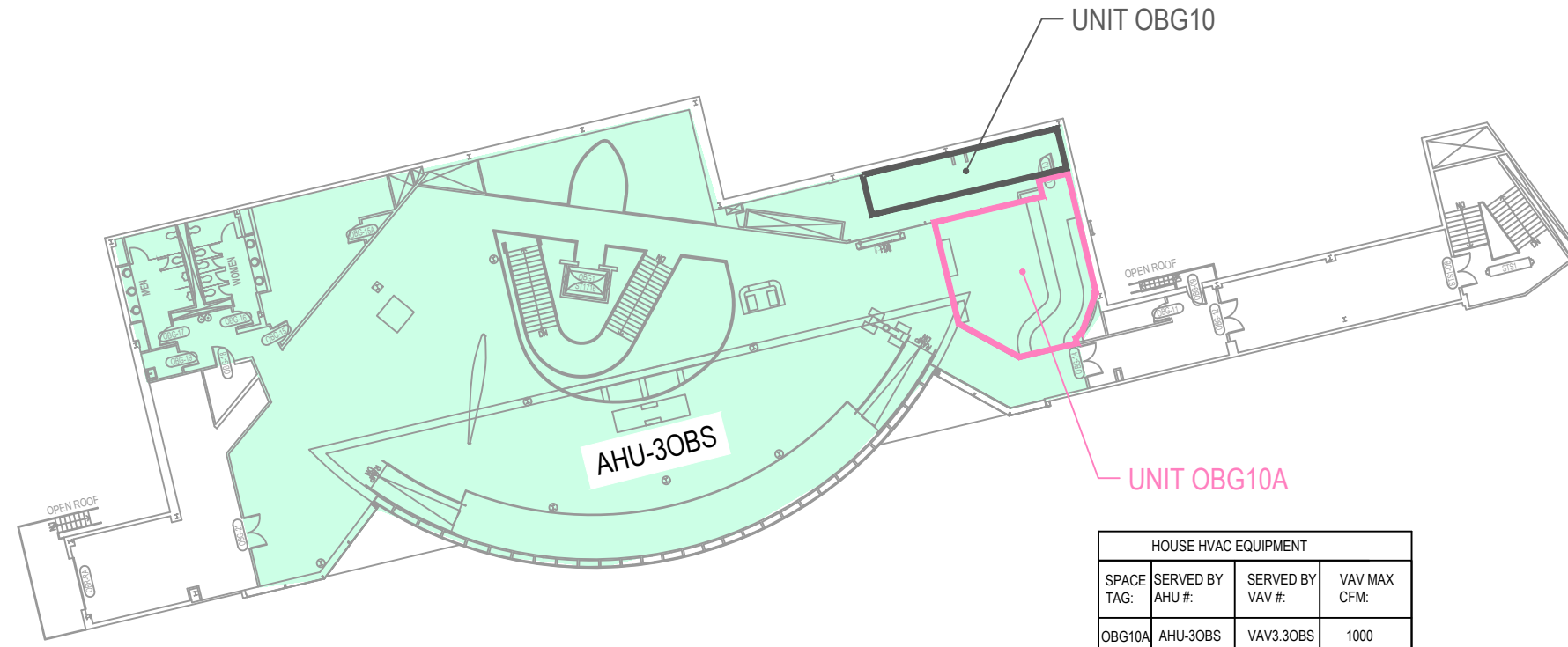

HOUSE HVAC EQUIPMENT			
SPACE TAG:	SERVED BY AHU #:	SERVED BY VAV #:	VAV MAX CFM:
OBG10A	AHU-3OBS	VAV3.3OBS	1000

HOUSE AHU AIRFLOW	
AHU TAG:	AHU MAX CFM:
AHU-3OBS	8000

1. REFER TO GROUND FLOOR DRAWINGS FOR LOCATIONS.
2. REFER TO FLOOR PLANS FOR AREAS SERVED.

## Concession Category

- |   |                    |   |                |
|---|--------------------|---|----------------|
|  | Food Service       |  | Services       |
|  | Convenience Retail |  | Support Space  |
|  | Specialty Retail   |  | MAA Controlled |
|  | Vending            |   |                |



SCALE: 1/32" = 1'-0"

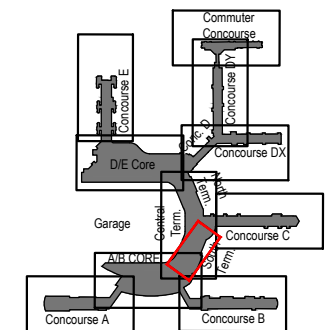

Key Plan: Airport



# Concourse A - Ground Level (Level 1a)

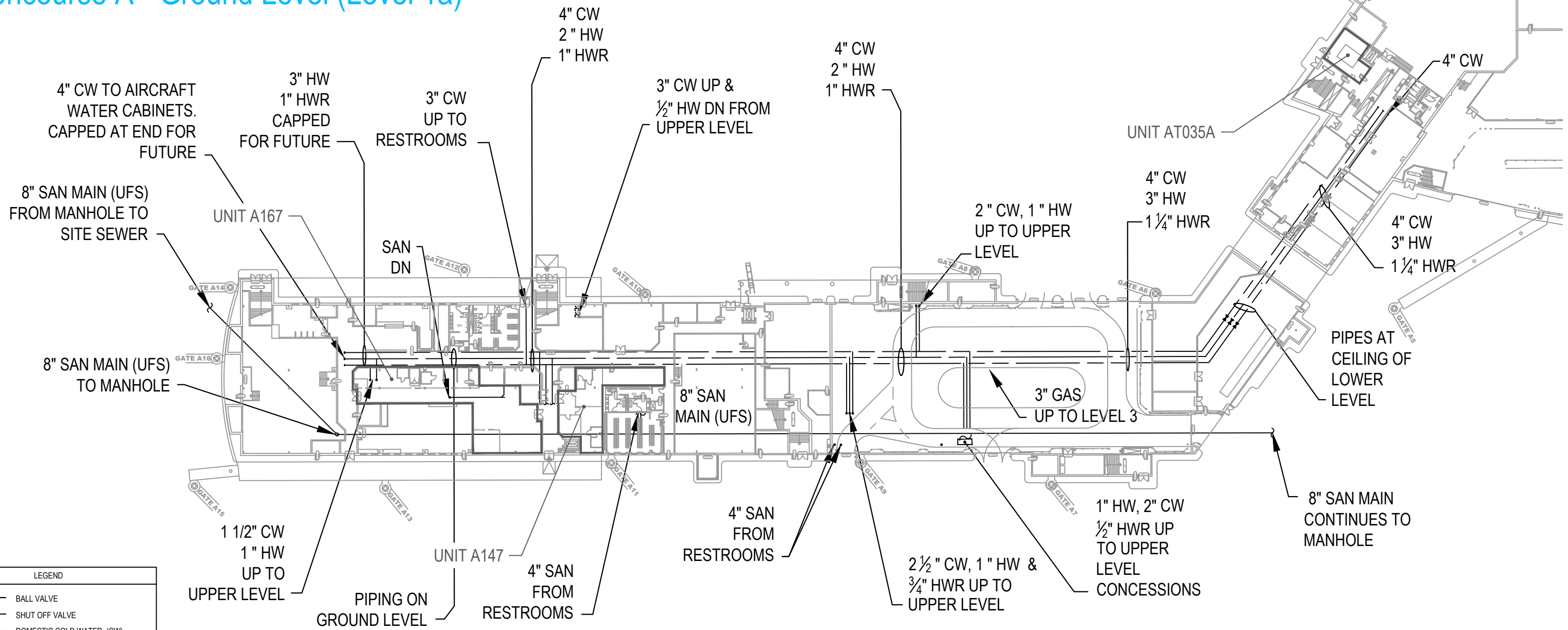

**LEGEND**

- BALL VALVE
- SHUT OFF VALVE
- DOMESTIC COLD WATER (CW)
- DOMESTIC HOT WATER (HW)
- DOMESTIC HOT WATER RECIRC. (HWR)
- ABOVE FINISHED FLOOR
- DRAINAGE FIXTURE UNIT
- WATER SUPPLY FIXTURE UNIT
- NOT APPLICABLE
- UNDER FLOOR SLAB

**SPARE PLUMBING CAPACITY\***

MAIN TYPE	MAIN SIZE	SUPPLY WATER CAPACITY (WSFU)	WASTE LINE CAPACITY (DFU)
CW	4"	1755	NA
HW	3"	620	NA
SAN	4"	NA	1300

\* REFER TO THE PLUMBING NARRATIVE FOR CAPACITY DETERMINATION AND LIMITATIONS.

**Concession Category**

- Food Service
- Services
- Convenience Retail
- Support Space
- Specialty Retail
- MAA Controlled
- Vending

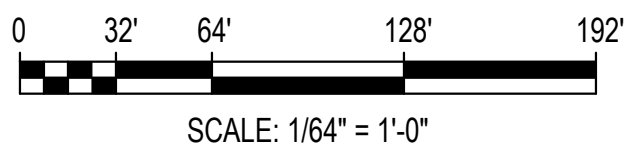
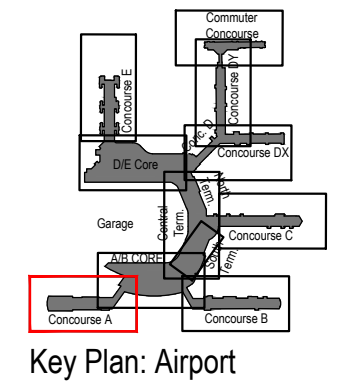

# A/B Core - Ground Level (Level 1a)

SPARE PLUMBING CAPACITY*			
MAIN TYPE	MAIN SIZE	SUPPLY WATER CAPACITY (WSFU)	WASTE LINE CAPACITY (DFU)
CW	6"	2000	NA
HW	3"	750	NA
SAN	4"	NA	1200

\* REFER TO THE PLUMBING NARRATIVE FOR CAPACITY DETERMINATION AND LIMITATIONS.

LEGEND	
	BALL VALVE
	SHUT OFF VALVE
	DOMESTIC COLD WATER (CW)
	DOMESTIC HOT WATER (HW)
	DOMESTIC HOT WATER RECIRC. (HWR)
AFF	ABOVE FINISHED FLOOR
DFU	DRAINAGE FIXTURE UNIT
WSFU	WATER SUPPLY FIXTURE UNIT
NA	NOT APPLICABLE
UFS	UNDER FLOOR SLAB

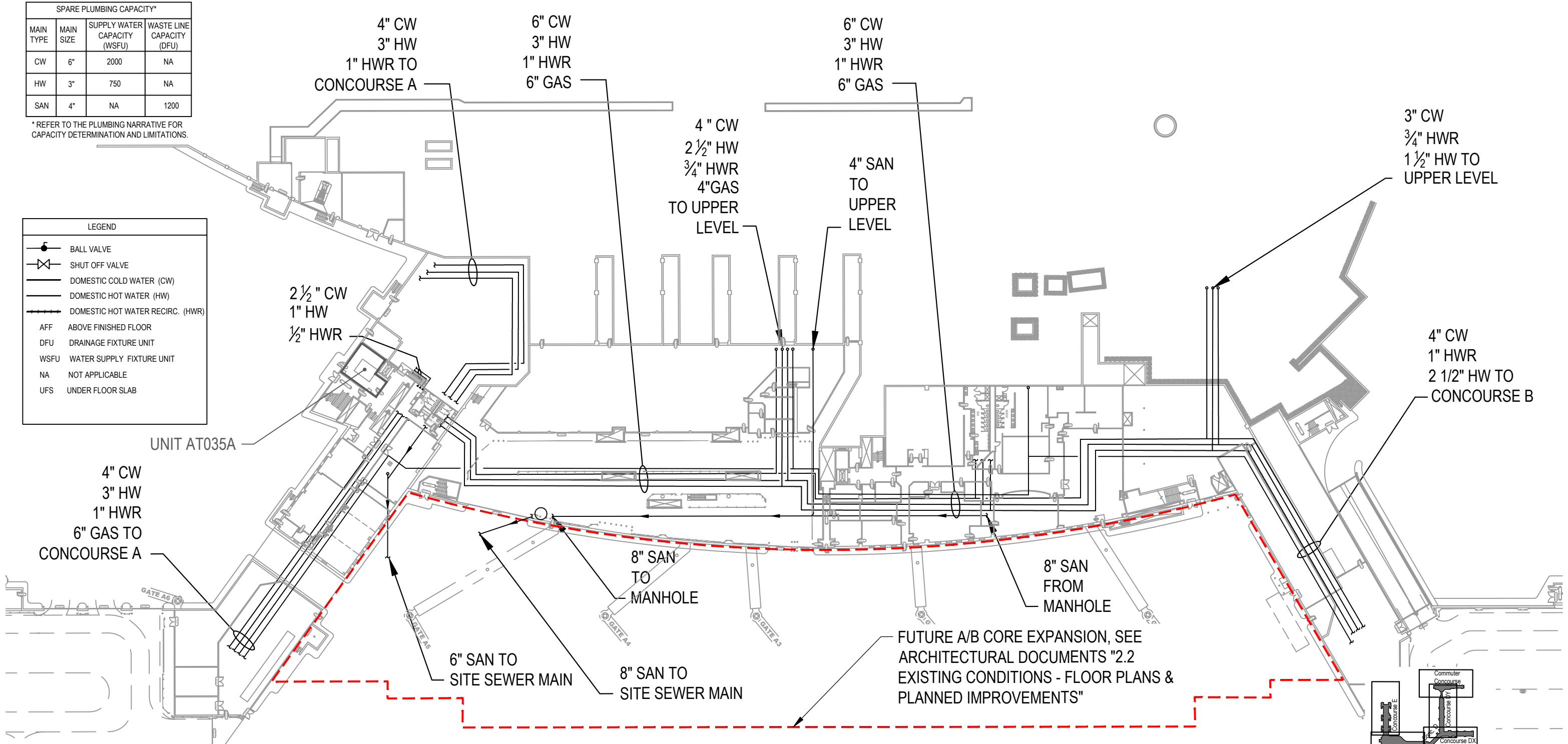

### Concession Category

- Food Service
- Services
- Convenience Retail
- Support Space
- Specialty Retail
- MAA Controlled
- Vending



SCALE: 1/64" = 1'-0"

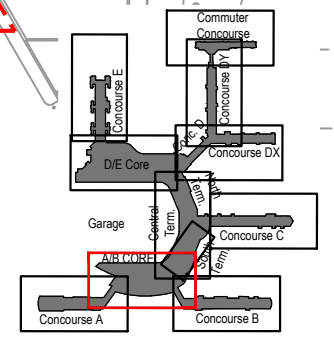

Key Plan: Airport

# Concourse B - Ground Level (Level 1a)

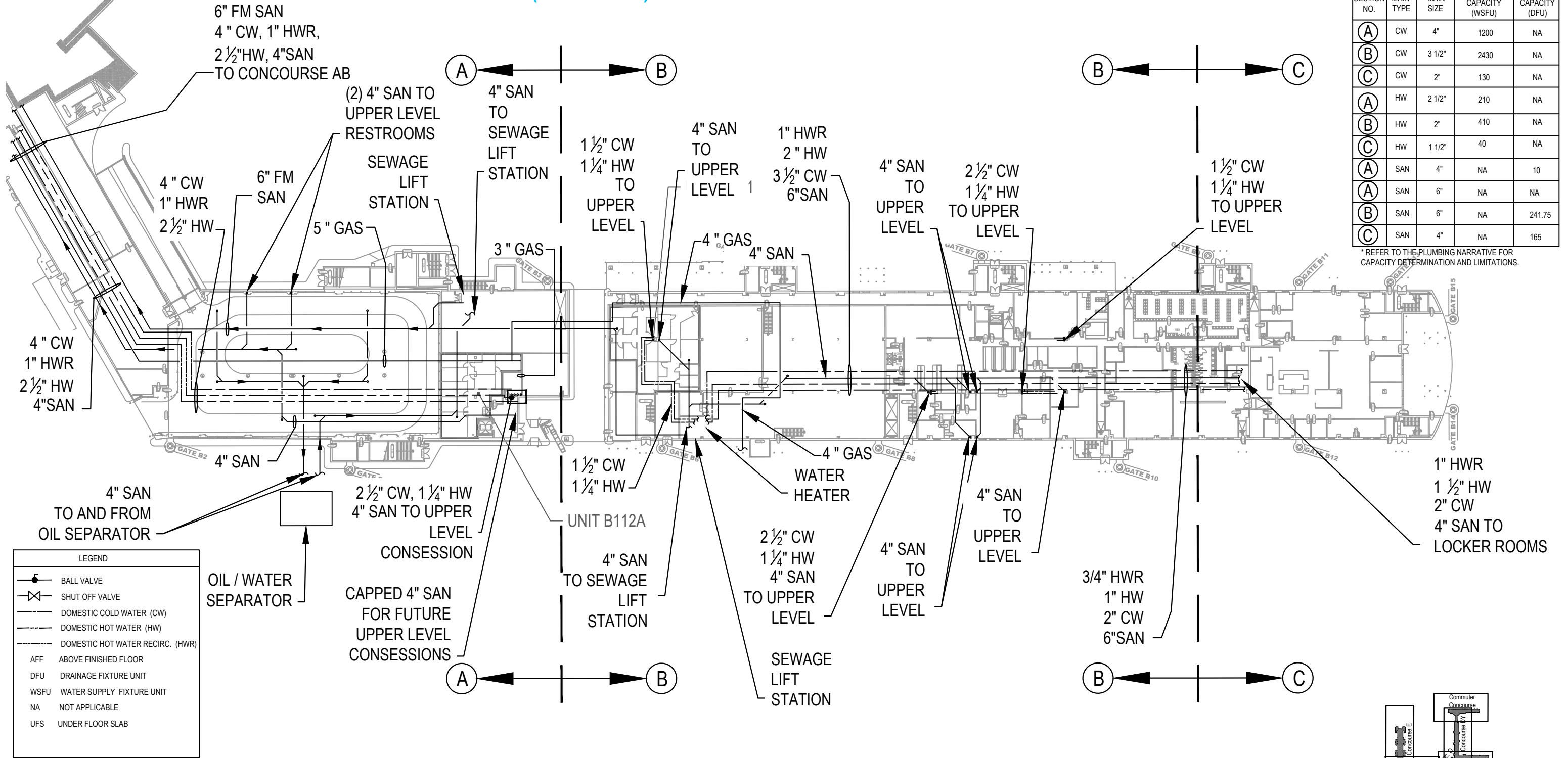

SPARE PLUMBING CAPACITY*				
SECTION NO.	MAIN TYPE	MAIN SIZE	SUPPLY WATER CAPACITY (WSFU)	WASTE LINE CAPACITY (DFU)
(A)	CW	4"	1200	NA
(B)	CW	3 1/2"	2430	NA
(C)	CW	2"	130	NA
(A)	HW	2 1/2"	210	NA
(B)	HW	2"	410	NA
(C)	HW	1 1/2"	40	NA
(A)	SAN	4"	NA	10
(A)	SAN	6"	NA	NA
(B)	SAN	6"	NA	241.75
(C)	SAN	4"	NA	165

\*REFER TO THE PLUMBING NARRATIVE FOR CAPACITY DETERMINATION AND LIMITATIONS.

LEGEND	
	BALL VALVE
	SHUT OFF VALVE
	DOMESTIC COLD WATER (CW)
	DOMESTIC HOT WATER (HW)
	DOMESTIC HOT WATER RECIRC. (HWR)
AFF	ABOVE FINISHED FLOOR
DFU	DRAINAGE FIXTURE UNIT
WSFU	WATER SUPPLY FIXTURE UNIT
NA	NOT APPLICABLE
UFS	UNDER FLOOR SLAB

Concession Category	
	Food Service
	Convenience Retail
	Specialty Retail
	Vending
	Services
	Support Space
	MAA Controlled

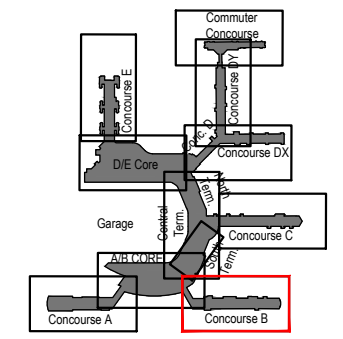
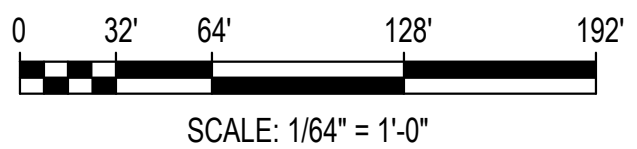



# A/B Core - Lower Level (Level 1)

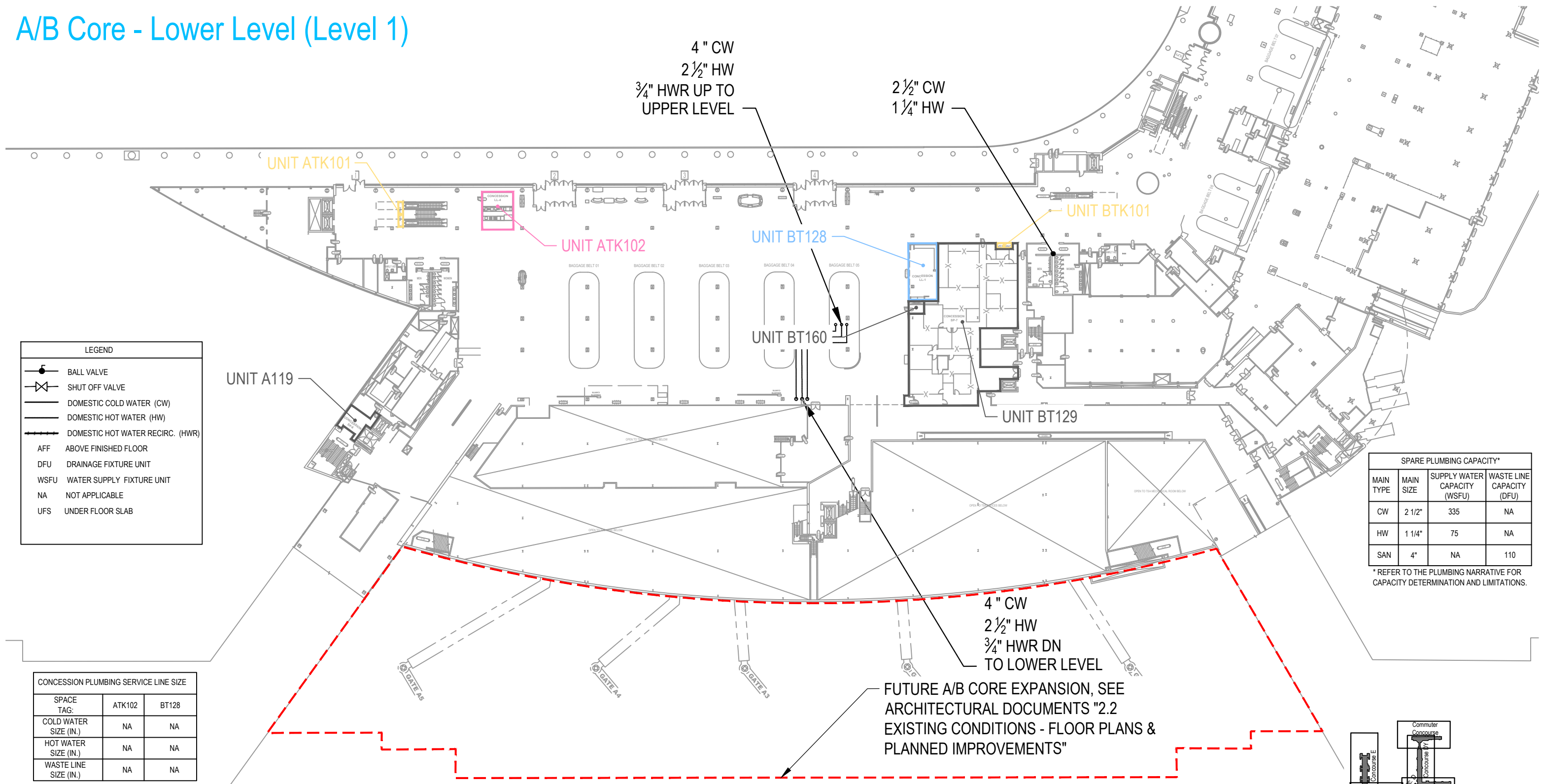

**LEGEND**

- BALL VALVE
- SHUT OFF VALVE
- DOMESTIC COLD WATER (CW)
- DOMESTIC HOT WATER (HW)
- DOMESTIC HOT WATER RECIRC. (HWR)
- AFF ABOVE FINISHED FLOOR
- DFU DRAINAGE FIXTURE UNIT
- WSFU WATER SUPPLY FIXTURE UNIT
- NA NOT APPLICABLE
- UFS UNDER FLOOR SLAB

**SPARE PLUMBING CAPACITY\***

MAIN TYPE	MAIN SIZE	SUPPLY WATER CAPACITY (WSFU)	WASTE LINE CAPACITY (DFU)
CW	2 1/2"	335	NA
HW	1 1/4"	75	NA
SAN	4"	NA	110

\* REFER TO THE PLUMBING NARRATIVE FOR CAPACITY DETERMINATION AND LIMITATIONS.

**CONCESSION PLUMBING SERVICE LINE SIZE**

SPACE TAG:	ATK102	BT128
COLD WATER SIZE (IN.)	NA	NA
HOT WATER SIZE (IN.)	NA	NA
WASTE LINE SIZE (IN.)	NA	NA

**Concession Category**

- Food Service
- Services
- Convenience Retail
- Support Space
- Specialty Retail
- MAA Controlled
- Vending

FUTURE A/B CORE EXPANSION, SEE ARCHITECTURAL DOCUMENTS "2.2 EXISTING CONDITIONS - FLOOR PLANS & PLANNED IMPROVEMENTS"

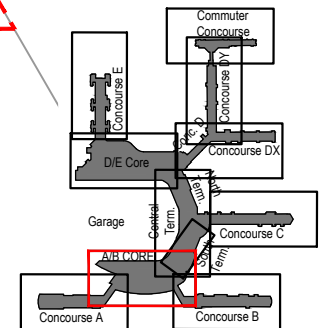

Key Plan: Airport



SCALE: 1/64" = 1'-0"



# Terminal South, Center, North - Lower Level (Level 1)

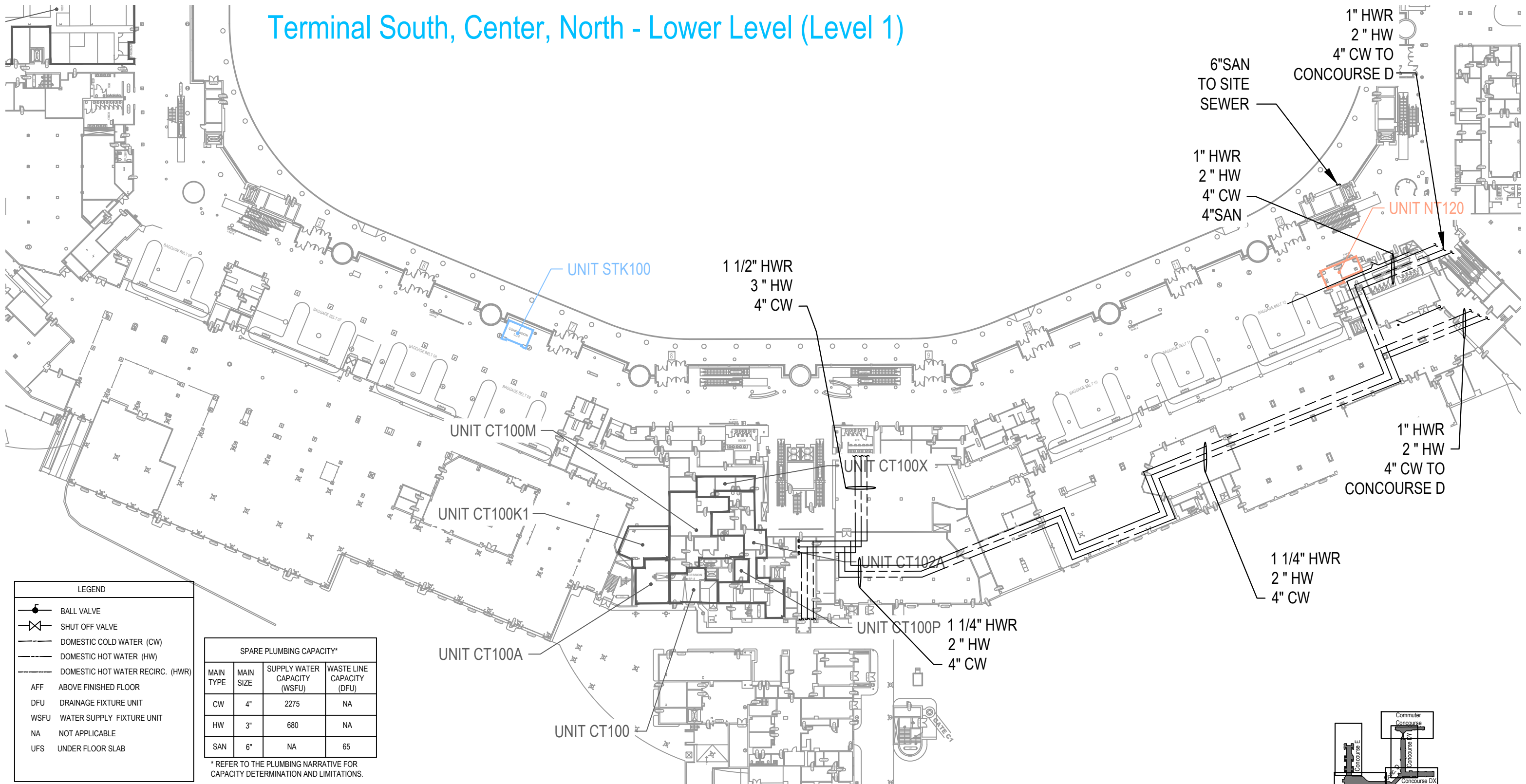

**LEGEND**

- BALL VALVE
- SHUT OFF VALVE
- DOMESTIC COLD WATER (CW)
- DOMESTIC HOT WATER (HW)
- DOMESTIC HOT WATER RECIRC. (HWR)
- AFF ABOVE FINISHED FLOOR
- DFU DRAINAGE FIXTURE UNIT
- WSFU WATER SUPPLY FIXTURE UNIT
- NA NOT APPLICABLE
- UFS UNDER FLOOR SLAB

SPARE PLUMBING CAPACITY*			
MAIN TYPE	MAIN SIZE	SUPPLY WATER CAPACITY (WSFU)	WASTE LINE CAPACITY (DFU)
CW	4"	2275	NA
HW	3"	680	NA
SAN	6"	NA	65

\* REFER TO THE PLUMBING NARRATIVE FOR CAPACITY DETERMINATION AND LIMITATIONS.

**Concession Category**

- Food Service
- Convenience Retail
- Specialty Retail
- Vending
- Services
- Support Space
- MAA Controlled

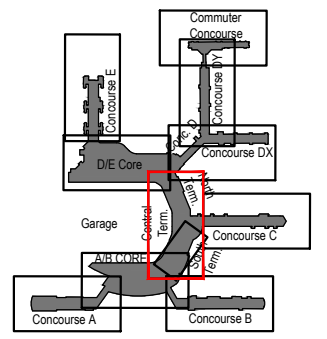
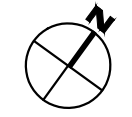
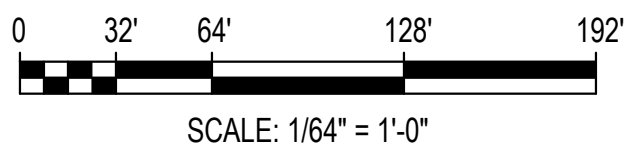

Key Plan: Airport

# Concourse C - Lower Level (Level 1)

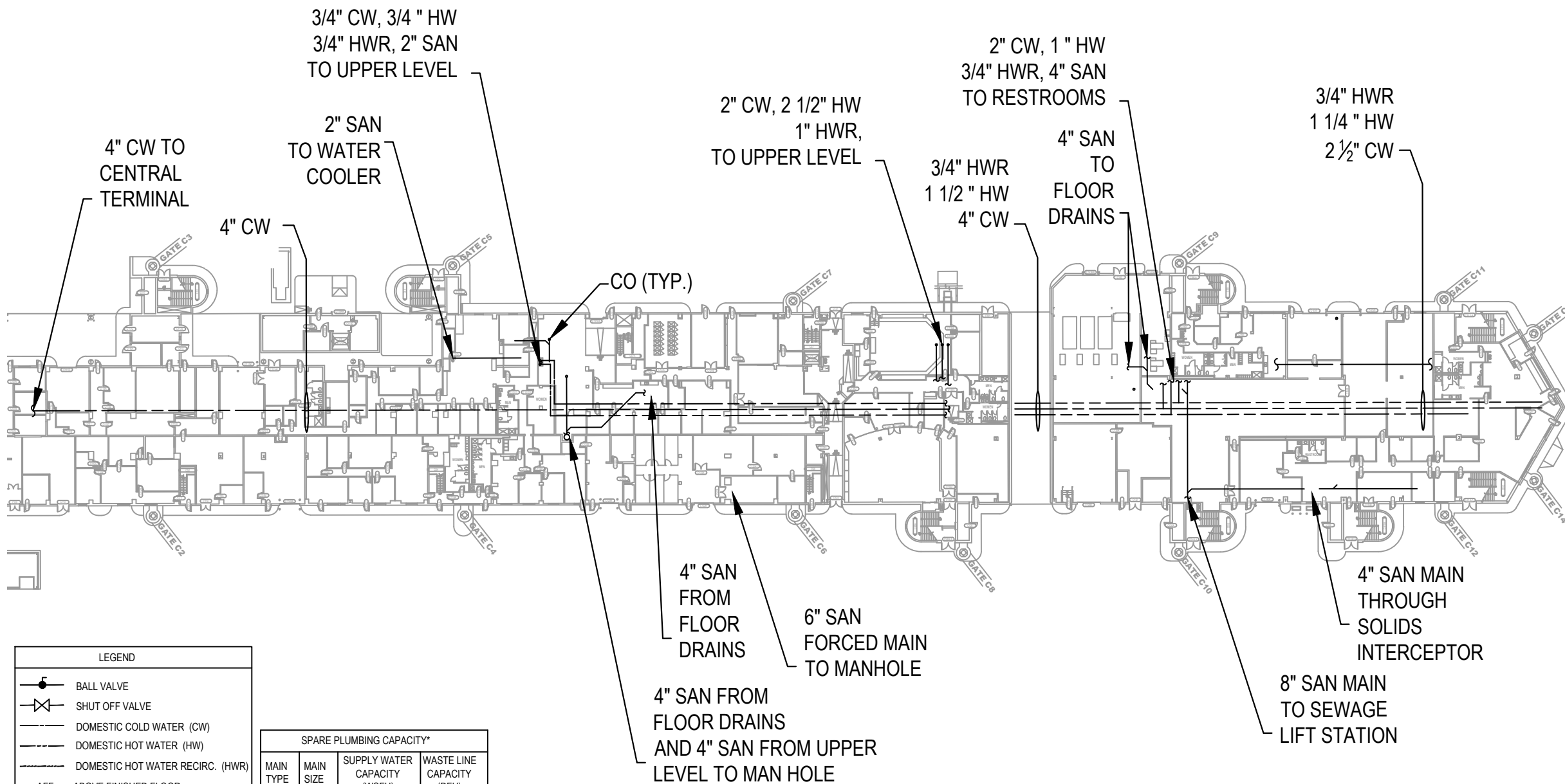

**LEGEND**

- BALL VALVE
- SHUT OFF VALVE
- DOMESTIC COLD WATER (CW)
- DOMESTIC HOT WATER (HW)
- DOMESTIC HOT WATER RECIRC. (HWR)
- AFF ABOVE FINISHED FLOOR
- DFU DRAINAGE FIXTURE UNIT
- WSFU WATER SUPPLY FIXTURE UNIT
- NA NOT APPLICABLE
- UFS UNDER FLOOR SLAB

**SPARE PLUMBING CAPACITY\***

MAIN TYPE	MAIN SIZE	SUPPLY WATER CAPACITY (WSFU)	WASTE LINE CAPACITY (DFU)
CW	4"	--	--
HW	3"	--	--
SAN	4"	--	--

\* REFER TO THE PLUMBING NARRATIVE FOR CAPACITY DETERMINATION AND LIMITATIONS.

**Concession Category**

- Food Service
- Convenience Retail
- Specialty Retail
- Vending
- Services
- Support Space
- MAA Controlled

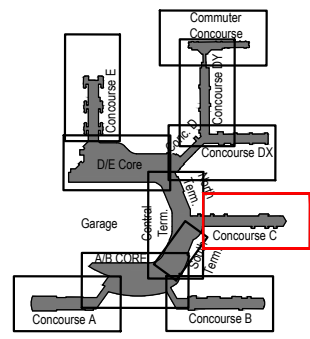
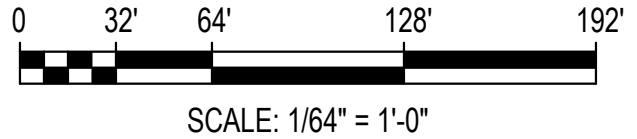

Key Plan: Airport



# Concourse D, DX - Lower Level (Level 1)

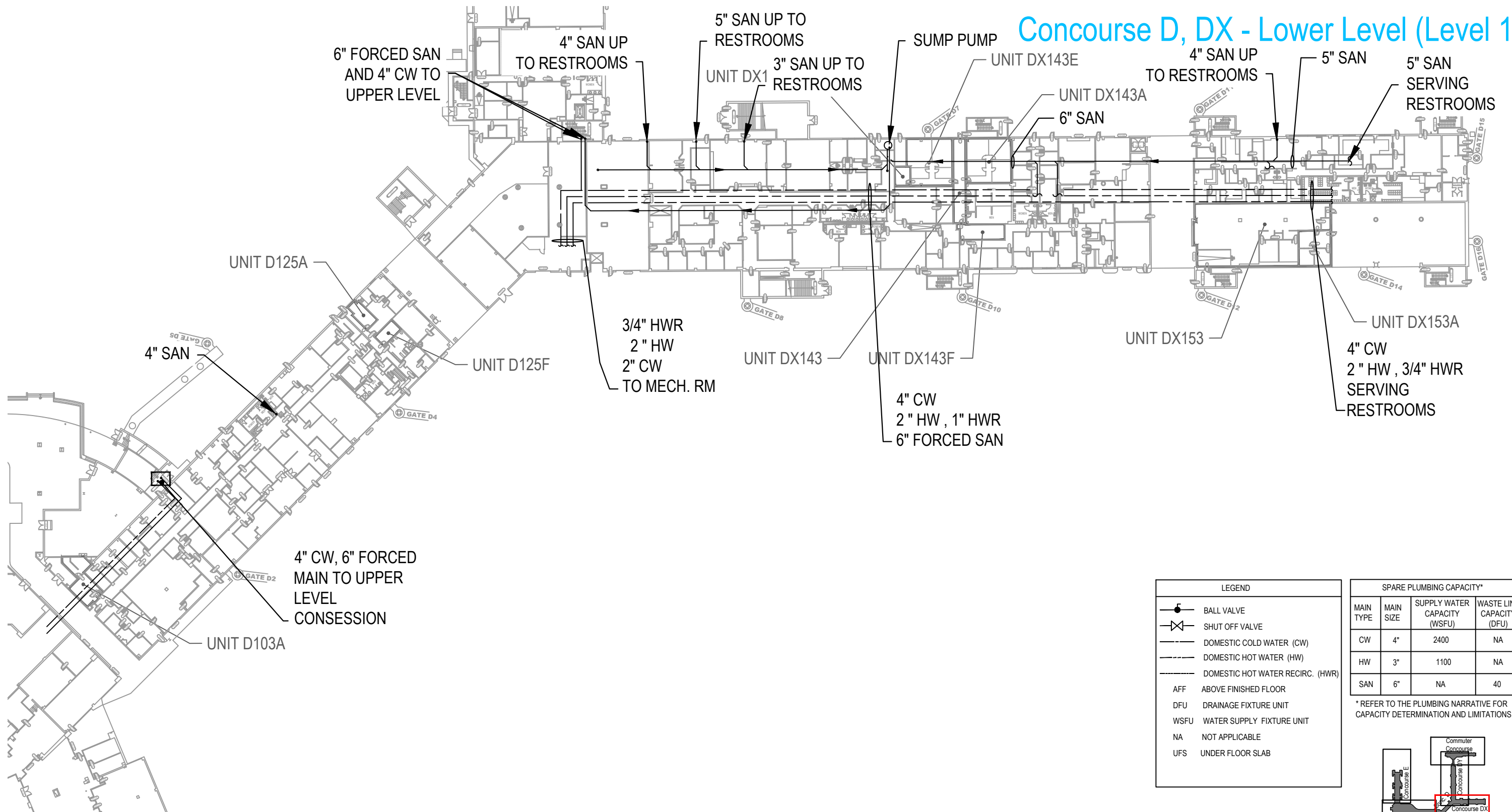

### Concession Category

- Food Service
- Convenience Retail
- Specialty Retail
- Vending
- Services
- Support Space
- MAA Controlled

LEGEND	
	BALL VALVE
	SHUT OFF VALVE
	DOMESTIC COLD WATER (CW)
	DOMESTIC HOT WATER (HW)
	DOMESTIC HOT WATER RECIRC. (HWR)
AFF	ABOVE FINISHED FLOOR
DFU	DRAINAGE FIXTURE UNIT
WSFU	WATER SUPPLY FIXTURE UNIT
NA	NOT APPLICABLE
UFS	UNDER FLOOR SLAB

SPARE PLUMBING CAPACITY*			
MAIN TYPE	MAIN SIZE	SUPPLY WATER CAPACITY (WSFU)	WASTE LINE CAPACITY (DFU)
CW	4"	2400	NA
HW	3"	1100	NA
SAN	6"	NA	40

\* REFER TO THE PLUMBING NARRATIVE FOR CAPACITY DETERMINATION AND LIMITATIONS.

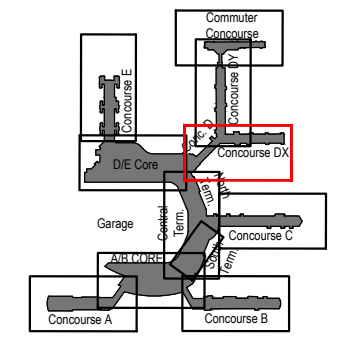

Key Plan: Airport



SCALE: 1/64" = 1'-0"

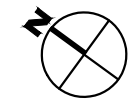



# Concourse DY - Lower Level (Level 1)

LEGEND	
	BALL VALVE
	SHUT OFF VALVE
	DOMESTIC COLD WATER (CW)
	DOMESTIC HOT WATER (HW)
	DOMESTIC HOT WATER RECIRC. (HWR)
AFF	ABOVE FINISHED FLOOR
DFU	DRAINAGE FIXTURE UNIT
WSFU	WATER SUPPLY FIXTURE UNIT
NA	NOT APPLICABLE
UFS	UNDER FLOOR SLAB

SPARE PLUMBING CAPACITY*			
MAIN TYPE	MAIN SIZE	SUPPLY WATER CAPACITY (WSFU)	WASTE LINE CAPACITY (DFU)
CW	4"	1200	NA
HW	2"	40	NA
SAN	4"	NA	10

\* REFER TO THE PLUMBING NARRATIVE FOR CAPACITY DETERMINATION AND LIMITATIONS.

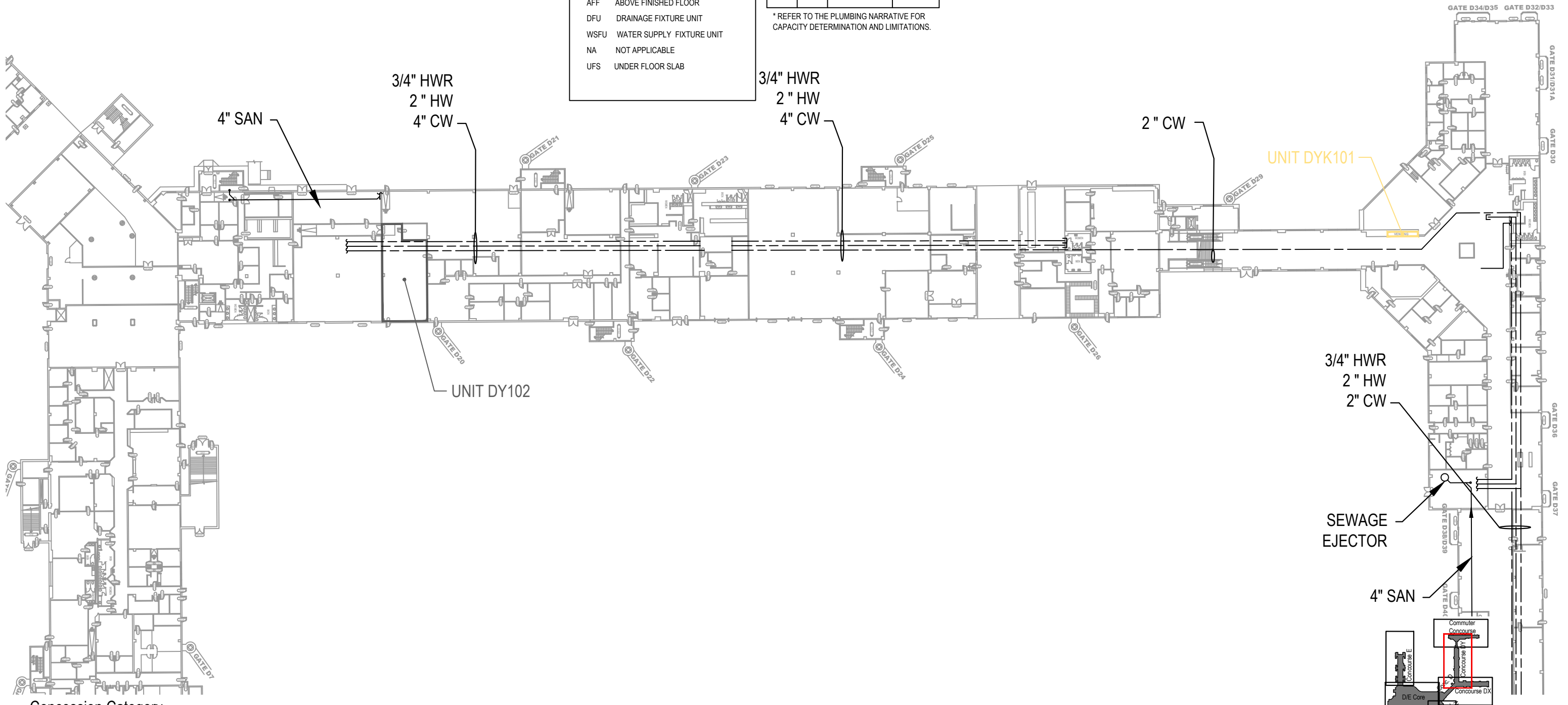

### Concession Category

- |  |                    |  |                |
|--|--------------------|--|----------------|
|  | Food Service       |  | Services       |
|  | Convenience Retail |  | Support Space  |
|  | Specialty Retail   |  | MAA Controlled |
|  | Vending            |  |                |



SCALE: 1/64" = 1'-0"

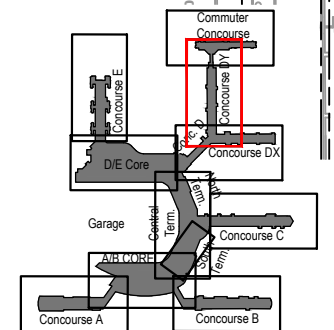

Key Plan: Airport

# Commuter Concourse D - Lower Level (Level 1)

LEGEND	
	BALL VALVE
	SHUT OFF VALVE
	DOMESTIC COLD WATER (CW)
	DOMESTIC HOT WATER (HW)
	DOMESTIC HOT WATER RECIRC. (HWR)
AFF	ABOVE FINISHED FLOOR
DFU	DRAINAGE FIXTURE UNIT
WSFU	WATER SUPPLY FIXTURE UNIT
NA	NOT APPLICABLE
UFS	UNDER FLOOR SLAB

SPARE PLUMBING CAPACITY*				
SECTION NO.	MAIN TYPE	MAIN SIZE	SUPPLY WATER CAPACITY (WSFU)	WASTE LINE CAPACITY (DFU)
(A)	CW	3"	1100	--
(B)	CW	3"	850	--
(C)	CW	2"	60	--
(A)	SAN	NA	NA	NA
(B)	SAN	6"	NA	2
(C)	SAN	4"	NA	25

\* REFER TO THE PLUMBING NARRATIVE FOR CAPACITY DETERMINATION AND LIMITATIONS.

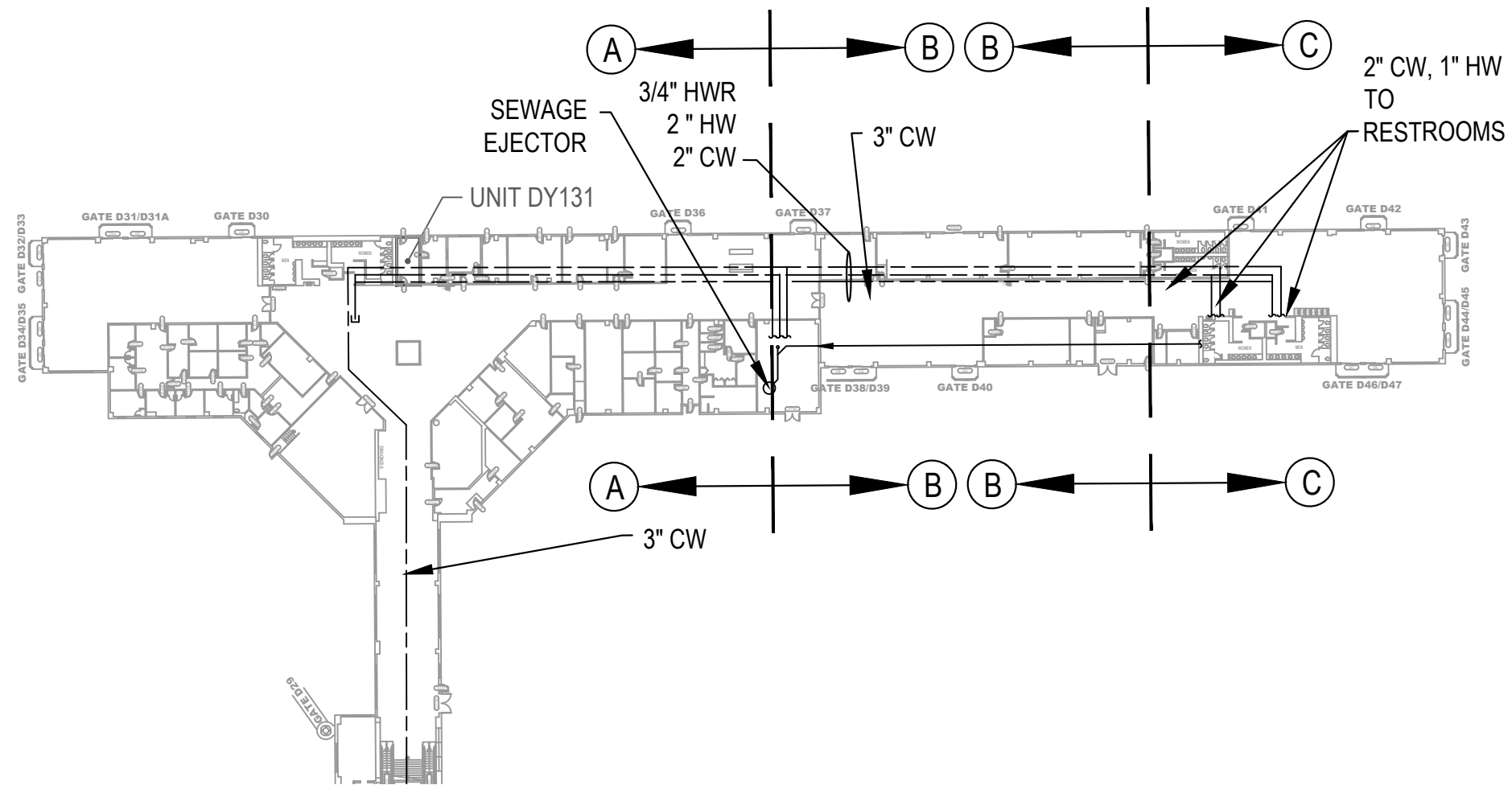

### Concession Category

	Food Service		Services
	Convenience Retail		Support Space
	Specialty Retail		MAA Controlled
	Vending		



SCALE: 1/64" = 1'-0"

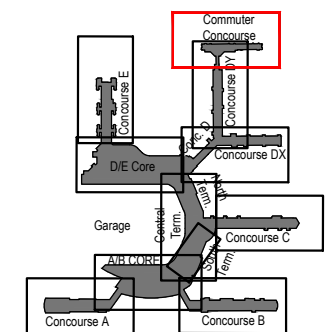

Key Plan: Airport

# D/E Core - Lower Level (Level 1)

LEGEND	
	BALL VALVE
	SHUT OFF VALVE
	DOMESTIC COLD WATER (CW)
	DOMESTIC HOT WATER (HW)
	DOMESTIC HOT WATER RECIRC. (HWR)
	AFF ABOVE FINISHED FLOOR
	DFU DRAINAGE FIXTURE UNIT
	WSFU WATER SUPPLY FIXTURE UNIT
	NA NOT APPLICABLE
	UFS UNDER FLOOR SLAB

PIPE MAIN - SPARE CAPACITY - DE CORE			
MAIN TYPE	MAIN SIZE	SUPPLY WATER CAPACITY (WSFU)	WASTE LINE CAPACITY (DFU)
CW	4"	NA	NA
HW	3"	NA	NA
SAN	4"	NA	NA

SPARE PLUMBING CAPACITY*			
SPACE TAG:	COLD WATER CAPACITY (WSFU)	HOT WATER CAPACITY (WSFU)	WASTE LINE CAPACITY (DFU)
EK105	14	15	155

\* REFER TO THE PLUMBING NARRATIVE FOR CAPACITY DETERMINATION AND LIMITATIONS.

CONCESSION PLUMBING SERVICE SIZE	
SPACE TAG:	EK105
COLD WATER SIZE (IN.)	1 1/4"
HOT WATER SIZE (IN.)	1"
WASTE LINE SIZE (IN.)	4"

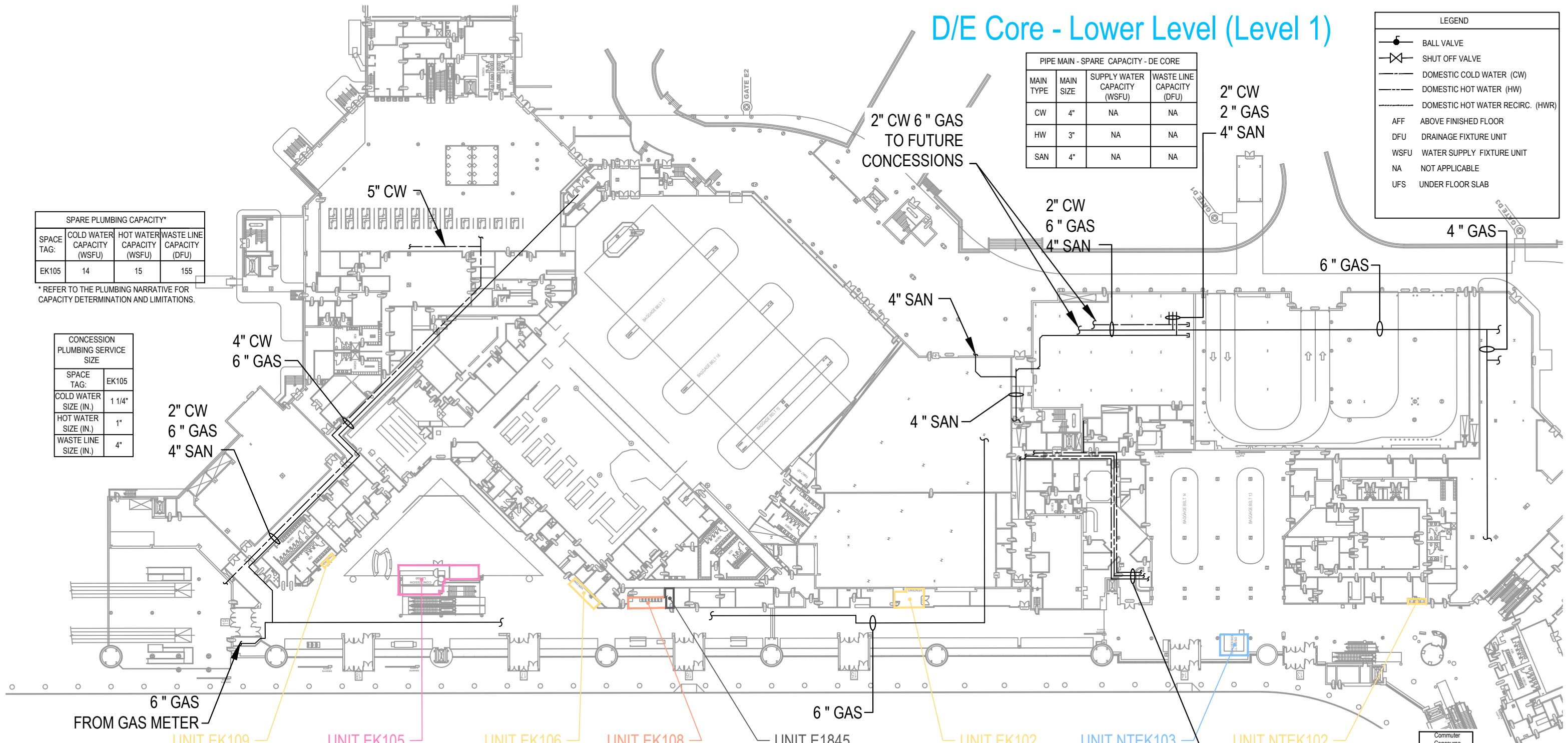

### Concession Category

- Food Service
- Convenience Retail
- Specialty Retail
- Vending
- Services
- Support Space
- MAA Controlled



SCALE: 1/64" = 1'-0"

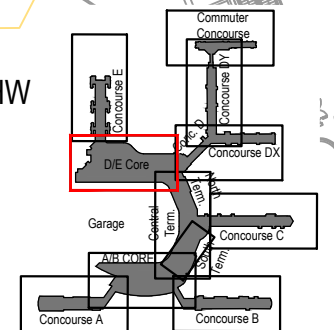

Key Plan: Airport

# Concourse E - Lower Level (Level 1)

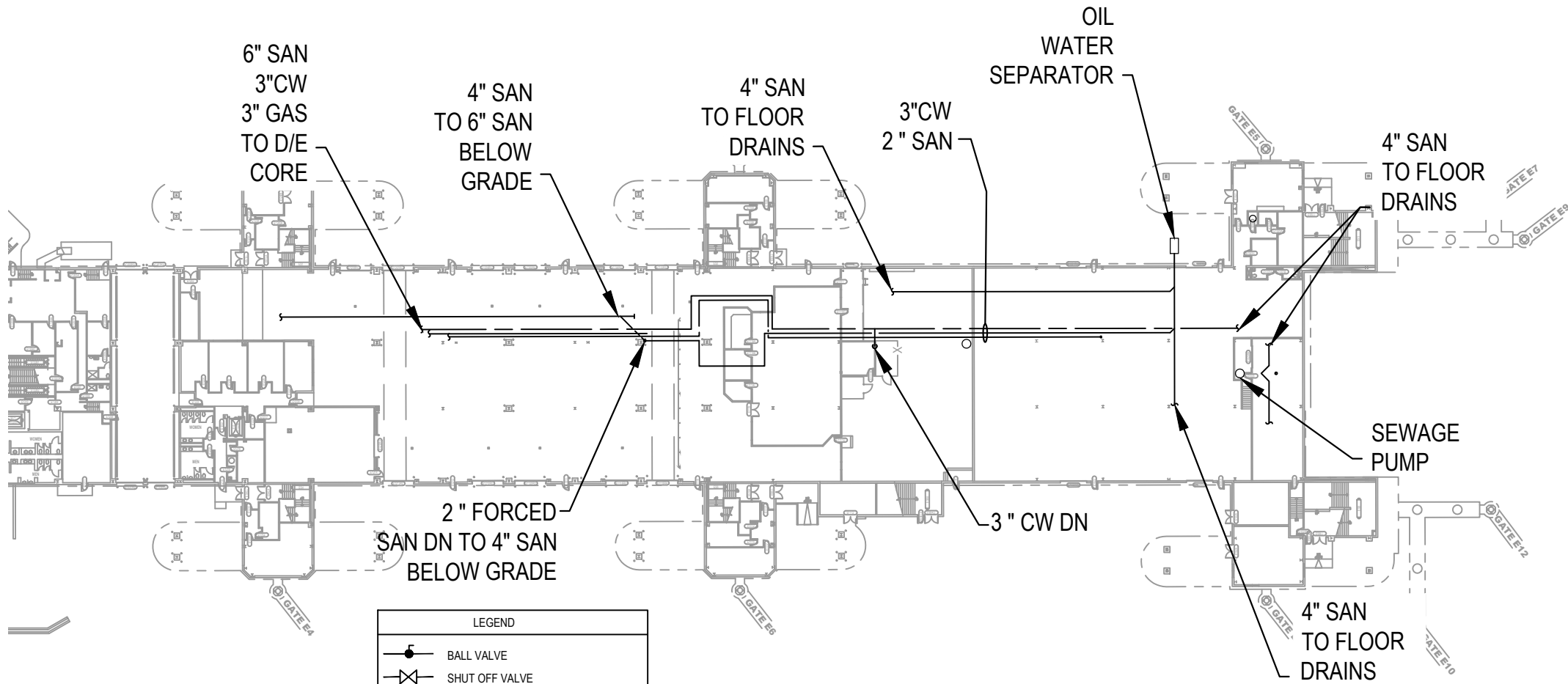

**LEGEND**

- BALL VALVE
- SHUT OFF VALVE
- DOMESTIC COLD WATER (CW)
- DOMESTIC HOT WATER (HW)
- DOMESTIC HOT WATER RECIRC. (HWR)
- AFF ABOVE FINISHED FLOOR
- DFU DRAINAGE FIXTURE UNIT
- WSFU WATER SUPPLY FIXTURE UNIT
- NA NOT APPLICABLE
- UFS UNDER FLOOR SLAB

**SPARE PLUMBING CAPACITY\***

MAIN TYPE	MAIN SIZE	SUPPLY WATER CAPACITY (WSFU)	WASTE LINE CAPACITY (DFU)
CW	4"	1500	--
HW	3"	575	--
SAN	6"	--	115

\* REFER TO THE PLUMBING NARRATIVE FOR CAPACITY DETERMINATION AND LIMITATIONS.

**Concession Category**

- Food Service
- Services
- Convenience Retail
- Support Space
- Specialty Retail
- MAA Controlled
- Vending

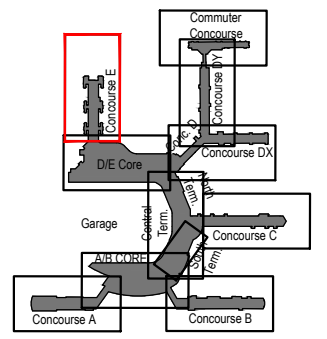
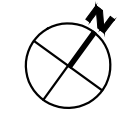
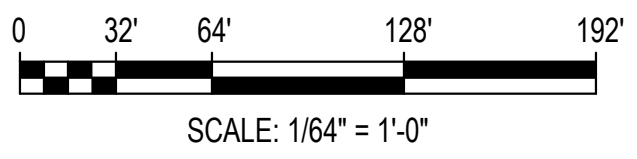

Key Plan: Airport



# Concourse A - Upper Level (Level 2)

SPARE PLUMBING CAPACITY*			
SPACE TAG:	COLD WATER CAPACITY (WSFU)	HOT WATER CAPACITY (WSFU)	WASTE LINE CAPACITY (DFU)
A239	100	35	90
A231	NA	NA	NA
A212A A212C	210	33	130
A212B	3	5	115
A211A	6	NA	140
A211B	8	NA	122
AK204	110	25	130
A201	6	NA	140

\* REFER TO THE PLUMBING NARRATIVE FOR CAPACITY DETERMINATION AND LIMITATIONS.

CONCESSION PLUMBING SERVICE LINE SIZE									
SPACE TAG:	A239	A231	A212A	A212C	A212B	A211A	A211B	AK204	A201
COLD WATER SIZE (IN.)	1 1/2"	NA	3/4"	2"	2"	3/4"	3/4"	1 1/2"	3/4"
HOT WATER SIZE (IN.)	1 1/4"	NA	3/4"	1"	1"	3/4"	3/4"	1 1/4"	3/4"
WASTE LINE SIZE (IN.)	4"	NA	4"	4"	4"	4"	4"	4"	4"

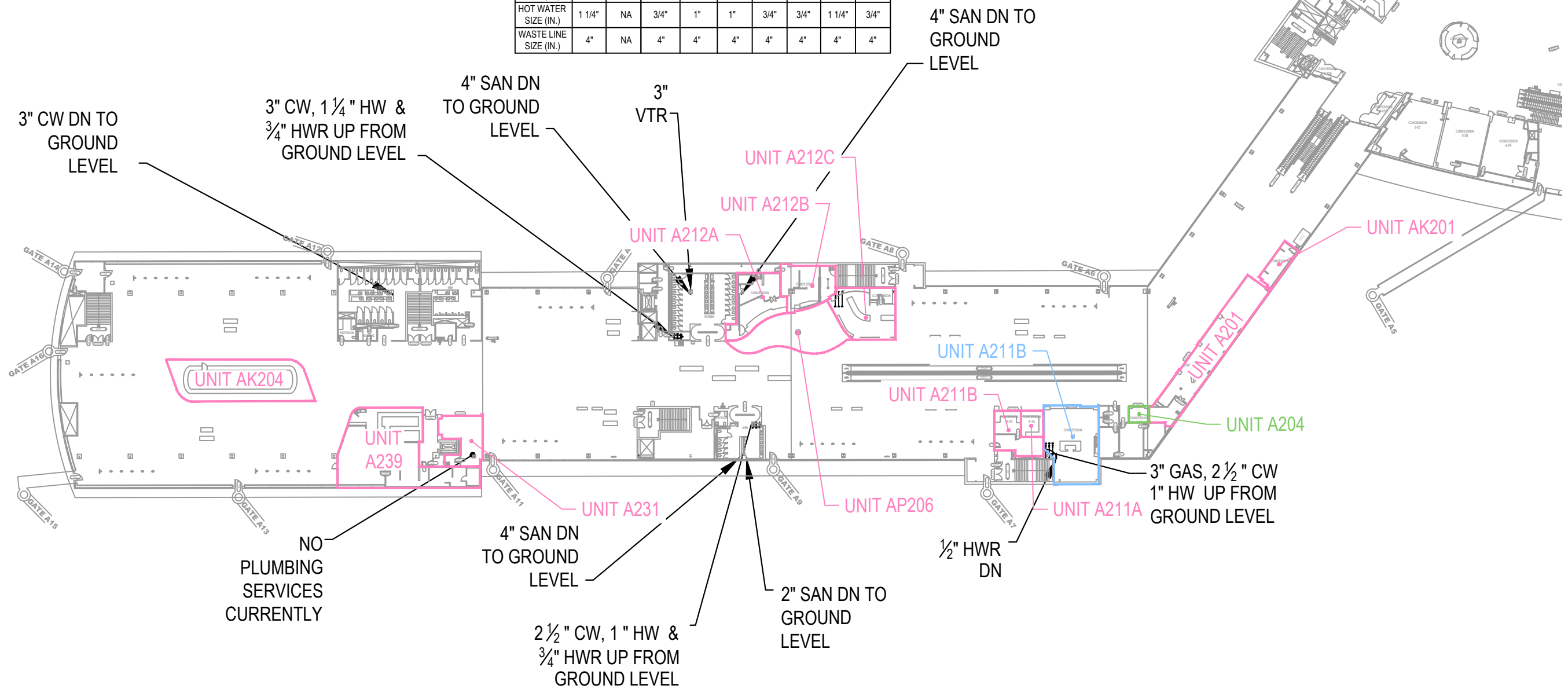

LEGEND	
	BALL VALVE
	SHUT OFF VALVE
	DOMESTIC COLD WATER (CW)
	DOMESTIC HOT WATER (HW)
	DOMESTIC HOT WATER RECIRC. (HWR)
AFF	ABOVE FINISHED FLOOR
DFU	DRAINAGE FIXTURE UNIT
WSFU	WATER SUPPLY FIXTURE UNIT
NA	NOT APPLICABLE
UFS	UNDER FLOOR SLAB

### Concession Category

- Food Service
- Convenience Retail
- Specialty Retail
- Vending
- Services
- Support Space
- MAA Controlled



SCALE: 1/64" = 1'-0"

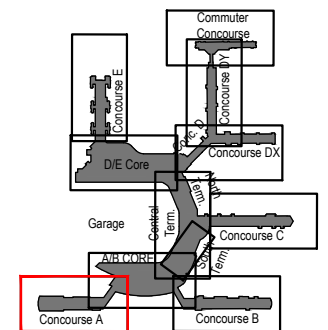

Key Plan: Airport

# A/B Core - Upper Level (Level 2)

**LEGEND**

- BALL VALVE
- SHUT OFF VALVE
- DOMESTIC COLD WATER (CW)
- DOMESTIC HOT WATER (HW)
- DOMESTIC HOT WATER RECIRC. (HWR)
- AFF ABOVE FINISHED FLOOR
- DFU DRAINAGE FIXTURE UNIT
- WSFU WATER SUPPLY FIXTURE UNIT
- NA NOT APPLICABLE
- UFS UNDER FLOOR SLAB

**SPARE PLUMBING CAPACITY**

SPACE TAG:	COLD WATER CAPACITY (WSFU)	HOT WATER CAPACITY (WSFU)	WASTE LINE CAPACITY (DFU)
BT275A	200	33	110
BT275B	8	14	118
AT275C	9	12	122
AT275D	4	8	104
AT275E	10	12	118
AT235	4	6	19
AT233	4	6	19
AT222	NA	NA	130
ATK202	NA	NA	16
AK201	3	5	115
A201	6	NA	140
A211B	8	NA	122
A204	110	25	130

**PIPE MAIN - SPARE CAPACITY - TERMINAL A**

MAIN TYPE	MAIN SIZE	SUPPLY WATER CAPACITY (WSFU)	WASTE LINE CAPACITY (DFU)
CW	4"	1755	NA
HW	3"	620	NA
SAN	4"	NA	90

**CONCESSION PLUMBING SERVICE LINE SIZE**

SPACE TAG:	BT275A	BT275B	AT275C	AT275D	AT275E	AT235	AT233	AT222	ATK202	AK201	A201	A211B	A204	BT250	BT210	BTK212	BT208	BT206	BT202	BK201
COLD WATER SIZE (IN.)	2"	1"	1"	3/4"	1"	3/4"	3/4"	?	1/2"	1"	3/4"	2"	2"	2"	2"	2"	1"	1/2"	2"	3/4"
HOT WATER SIZE (IN.)	1"	1"	1"	3/4"	1"	3/4"	3/4"	?	1/2"	1"	3/4"	1"	1"	1"	1"	1"	NA	1/2"	1"	1"
WASTE LINE SIZE (IN.)	4"	4"	4"	4"	4"	3"	3"	?	3"	4"	4"	4"	4"	4"	4"	4"	3"	3"	4"	3"

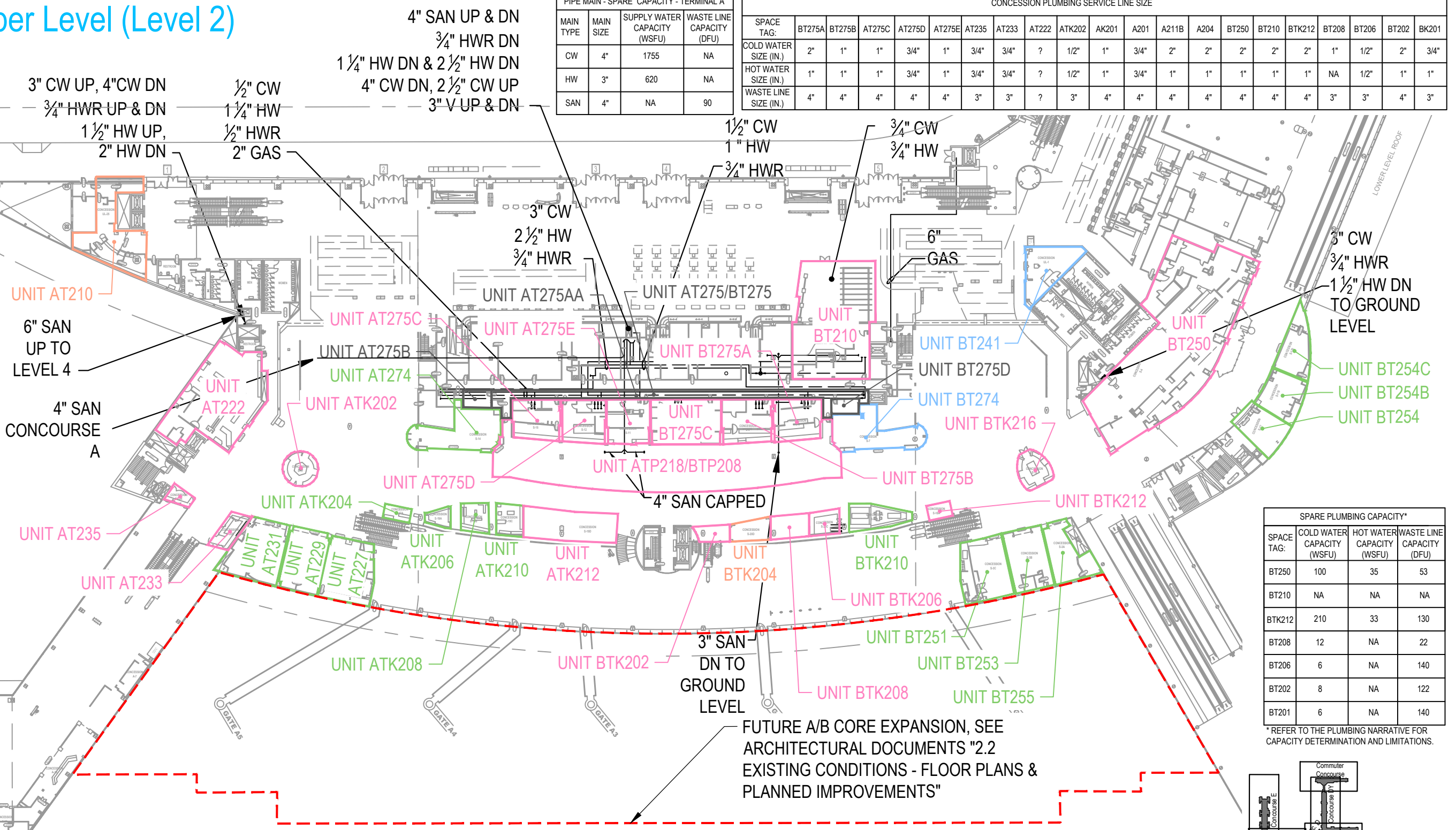

**SPARE PLUMBING CAPACITY\***

SPACE TAG:	COLD WATER CAPACITY (WSFU)	HOT WATER CAPACITY (WSFU)	WASTE LINE CAPACITY (DFU)
BT250	100	35	53
BT210	NA	NA	NA
BTK212	210	33	130
BT208	12	NA	22
BT206	6	NA	140
BT202	8	NA	122
BT201	6	NA	140

\* REFER TO THE PLUMBING NARRATIVE FOR CAPACITY DETERMINATION AND LIMITATIONS.

**Concession Category**

- Food Service
- Convenience Retail
- Specialty Retail
- Vending
- Services
- Support Space
- MAA Controlled



SCALE: 1/64" = 1'-0"

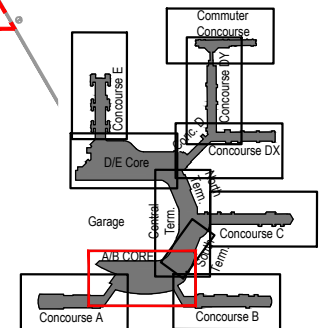
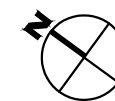

# Concourse B - Upper Level (Level 2)

SPARE PLUMBING CAPACITY*			
SPACE TAG:	COLD WATER CAPACITY (WSFU)	HOT WATER CAPACITY (WSFU)	WASTE LINE CAPACITY (DFU)
B240	NA	NA	30
B239	NA	NA	-10
B229	NA	NA	NA
B227	NA	NA	NA
B225	NA	NA	NA
B223A	3	3	31
B223B	3	5	31
B220A	NA	NA	NA
B217D	8	NA	122
B212	96.25	18.25	130
BK201	8	NA	122

\* REFER TO THE PLUMBING NARRATIVE FOR CAPACITY DETERMINATION AND LIMITATIONS.

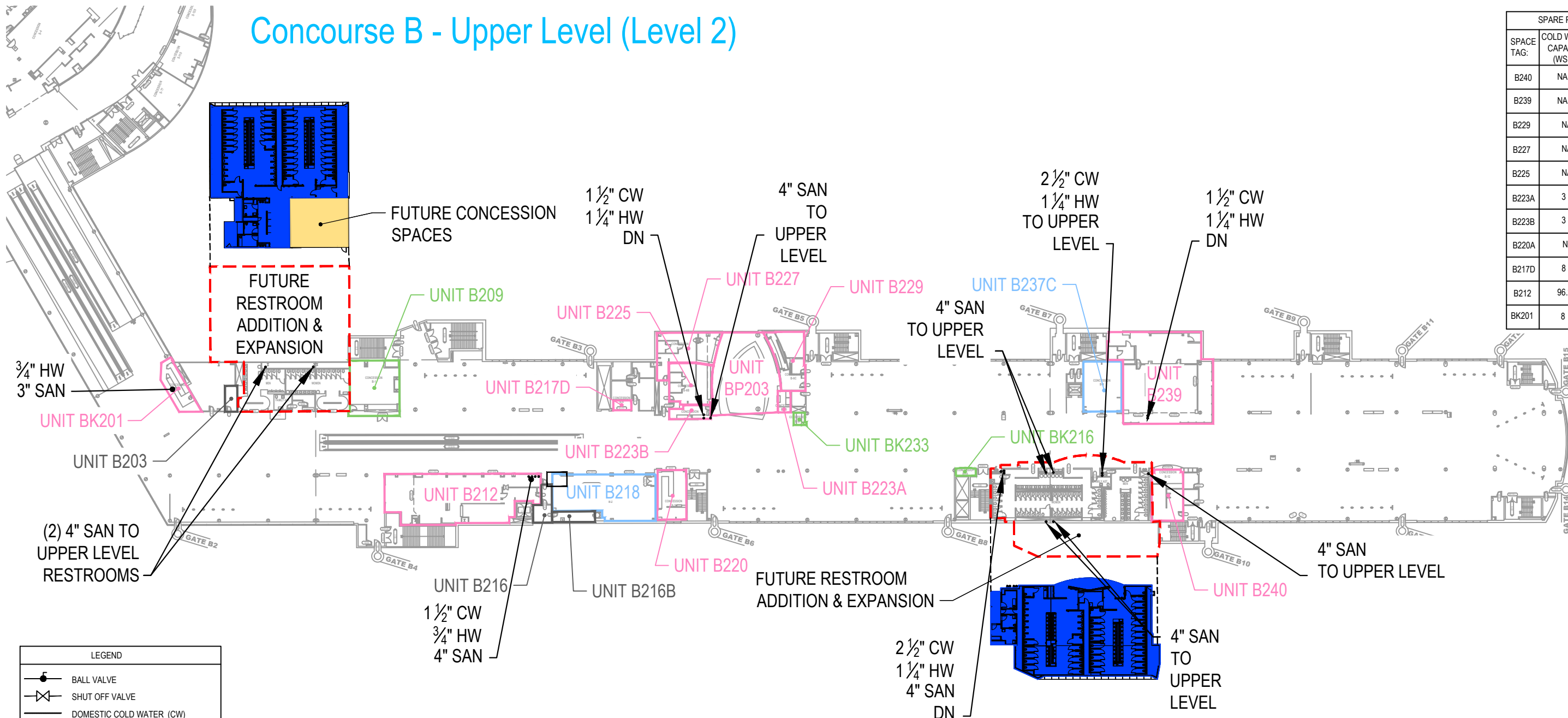

**LEGEND**

- BALL VALVE
- SHUT OFF VALVE
- DOMESTIC COLD WATER (CW)
- DOMESTIC HOT WATER (HW)
- DOMESTIC HOT WATER RECIRC. (HWR)
- AFF ABOVE FINISHED FLOOR
- DFU DRAINAGE FIXTURE UNIT
- WSFU WATER SUPPLY FIXTURE UNIT
- NA NOT APPLICABLE
- UFS UNDER FLOOR SLAB

PIPE MAIN - SPARE CAPACITY - CONCOURSE B\*\*

MAIN TYPE	MAIN SIZE	SUPPLY WATER CAPACITY (WSFU)	WASTE LINE CAPACITY (DFU)
CW	4"	--	--
HW	3"	--	--
SAN	4"	--	--

\*\*REFER TO LOWER LEVEL PLAN FOR PIPE MAINS

CONCESSION PLUMBING SERVICE LINE SIZE

SPACE TAG:	B240	B239	B229	B227	B225	B223A	B223B	B220A	B217D	B212	BK201
COLD WATER SIZE (IN.)	NA	NA	NA	3/4"	1/2"	3/4"	1 1/2"	NA	NA	1 1/2"	3/4"
HOT WATER SIZE (IN.)	NA	NA	NA	1/2"	1/2"	3/4"	1"	NA	NA	3/4"	NA
WASTE LINE SIZE (IN.)	4"	3"	NA	3"	3"	3"	3"	NA	NA	4"	3"

**Concession Category**

- Food Service
- Convenience Retail
- Specialty Retail
- Vending
- Services
- Support Space
- MAA Controlled

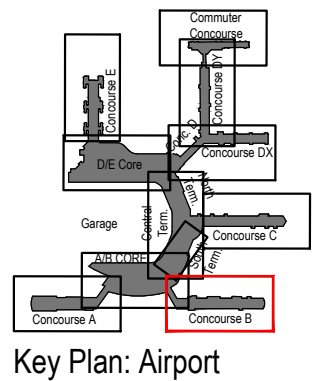
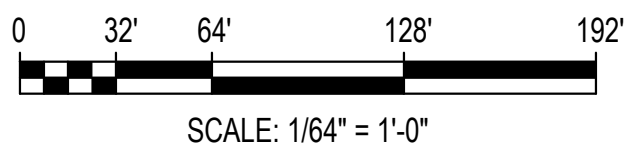



# Terminal South, Center, North - Upper Level (Level 2)

CONCESSION PLUMBING SERVICE LINE SIZE									
SPACE TAG:	SP203	ST205A	SPT207	ST200B	C200D	C200M	C200E1	NT237	NT243
COLD WATER SIZE (IN.)	1 1/2"	2"	1"	NA	1 1/4"	1 1/4"	1"	NA	1/2"
HOT WATER SIZE (IN.)	1"	1"	1"	NA	3/4"	3/4"	3/4"	NA	1/2"
WASTE LINE SIZE (IN.)	4"	4"	4"	NA	4"	NA	3"	NA	3"

SPARE PLUMBING CAPACITY*			
SPACE TAG:	COLD WATER CAPACITY (WSFU)	HOT WATER CAPACITY (WSFU)	WASTE LINE CAPACITY (DFU)
NT243	1/2"	1/2"	1
NT237	NA	NA	NA
C200D	80	8	110
C200E1	6	0	11
C200M	2	8	NA
ST200B	NA	NA	NA
STP207	6	10	25
ST205A	125	8	18
ST203	NA	NA	40

LEGEND	
	BALL VALVE
	SHUT OFF VALVE
	DOMESTIC COLD WATER (CW)
	DOMESTIC HOT WATER (HW)
	DOMESTIC HOT WATER RECIRC. (HWR)
AFF	ABOVE FINISHED FLOOR
DFU	DRAINAGE FIXTURE UNIT
WSFU	WATER SUPPLY FIXTURE UNIT
NA	NOT APPLICABLE
UFS	UNDER FLOOR SLAB

### Concession Category

- Food Service
- Convenience Retail
- Specialty Retail
- Vending
- Services
- Support Space
- MAA Controlled



SCALE: 1/64" = 1'-0"

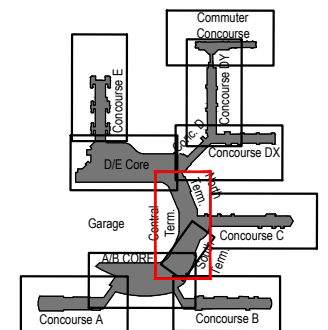

Key Plan: Airport

# Concourse C - Upper Level (Level 2)

LEGEND	
	BALL VALVE
	SHUT OFF VALVE
	DOMESTIC COLD WATER (CW)
	DOMESTIC HOT WATER (HW)
	DOMESTIC HOT WATER RECIRC. (HWR)
AFF	ABOVE FINISHED FLOOR
DFU	DRAINAGE FIXTURE UNIT
WSFU	WATER SUPPLY FIXTURE UNIT
NA	NOT APPLICABLE
UFS	UNDER FLOOR SLAB

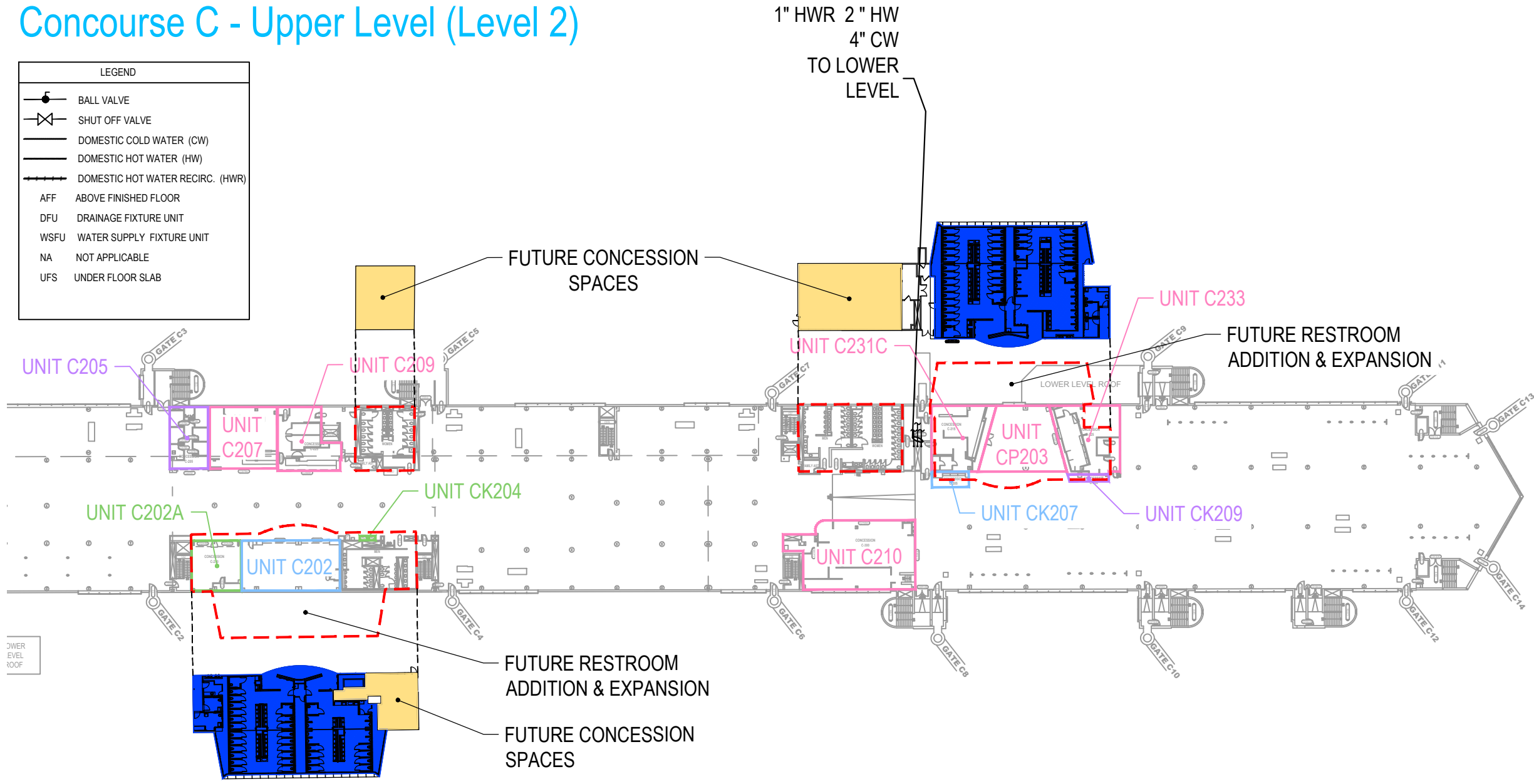

SPARE PLUMBING CAPACITY*			
SPACE TAG:	COLD WATER CAPACITY (WSFU)	HOT WATER CAPACITY (WSFU)	WASTE LINE CAPACITY (DFU)
C207	100	35	90
C209	NA	NA	100
C210	65	33	40
C231C	10	5	120
C233	15	NA	140
CP203	25	10	100

\*REFER TO THE PLUMBING NARRATIVE FOR CAPACITY DETERMINATION AND LIMITATIONS.

CONCESSION PLUMBING SERVICE LINE SIZE						
SPACE TAG:	C207	C209	C210	C231C	C233	CP203
COLD WATER SIZE (IN.)	1 1/2"	1"	3/4"	2"	2"	3/4"
HOT WATER SIZE (IN.)	1 1/4"	1"	3/4"	1"	1"	3/4"
WASTE LINE SIZE (IN.)	4"	NA	4"	4"	4"	4"

PIPE MAIN - SPARE CAPACITY - CONCOURSE B**			
MAIN TYPE	MAIN SIZE	SUPPLY WATER CAPACITY (WSFU)	WASTE LINE CAPACITY (DFU)
CW	4"	--	--
HW	3"	--	--
SAN	4"	--	--

\*\*REFER TO LOWER LEVEL PLAN FOR PIPE MAINS

### Concession Category

- Food Service
- Convenience Retail
- Specialty Retail
- Vending
- Services
- Support Space
- MAA Controlled

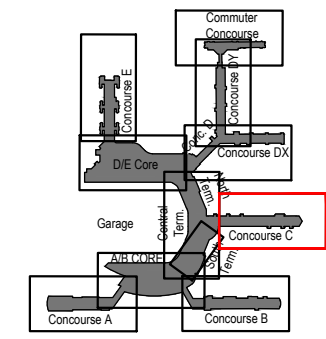
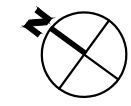
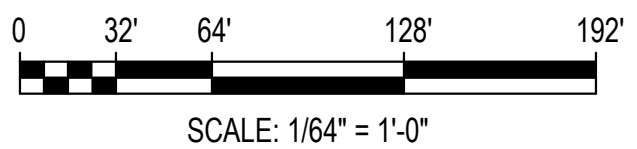

Key Plan: Airport

# Concourse D, DX - Upper Level (Level 2)

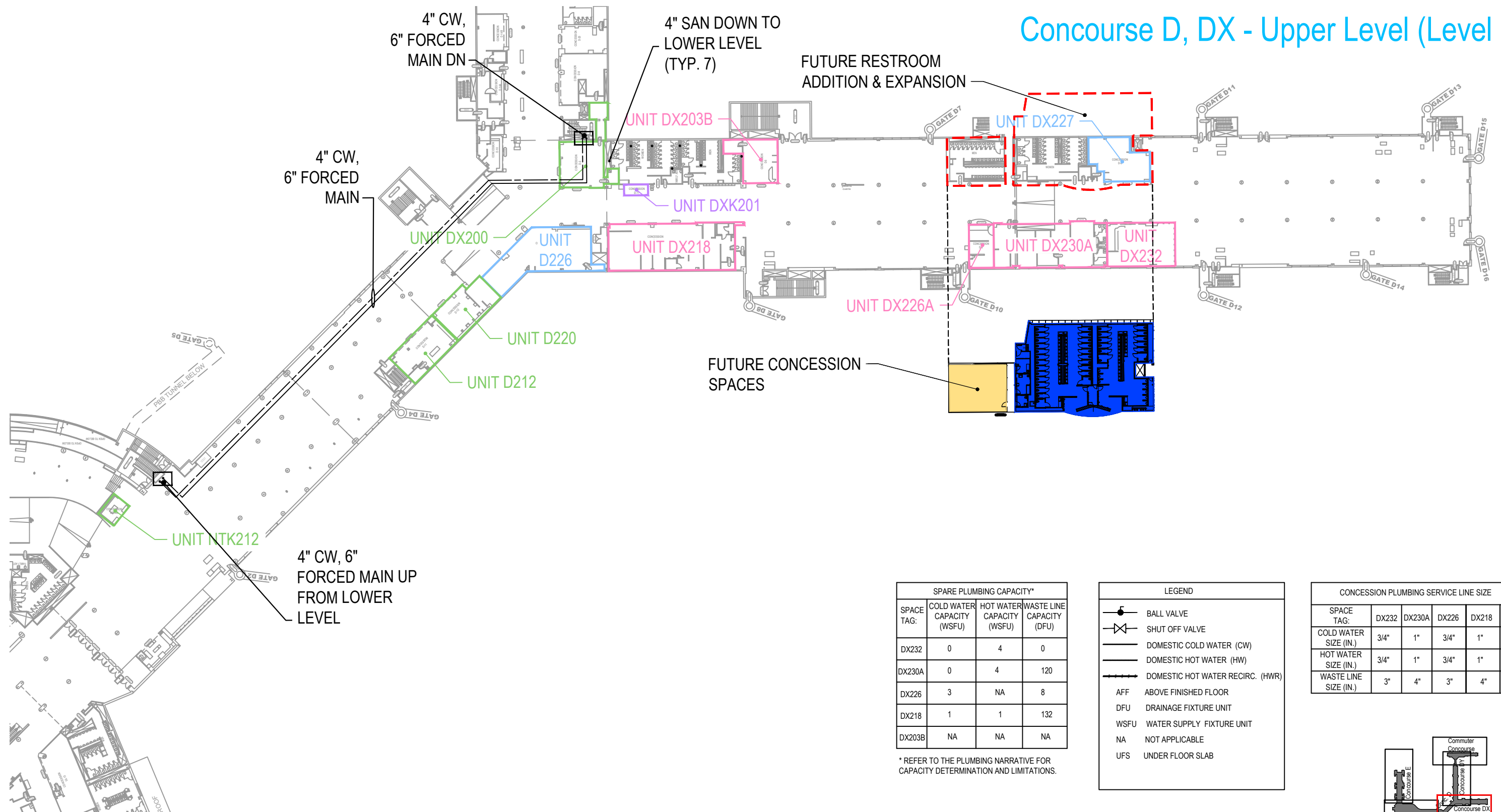

SPARE PLUMBING CAPACITY*			
SPACE TAG:	COLD WATER CAPACITY (WSFU)	HOT WATER CAPACITY (WSFU)	WASTE LINE CAPACITY (DFU)
DX232	0	4	0
DX230A	0	4	120
DX226	3	NA	8
DX218	1	1	132
DX203B	NA	NA	NA

\* REFER TO THE PLUMBING NARRATIVE FOR CAPACITY DETERMINATION AND LIMITATIONS.

LEGEND	
	BALL VALVE
	SHUT OFF VALVE
	DOMESTIC COLD WATER (CW)
	DOMESTIC HOT WATER (HW)
	DOMESTIC HOT WATER RECIRC. (HWR)
AFF	ABOVE FINISHED FLOOR
DFU	DRAINAGE FIXTURE UNIT
WSFU	WATER SUPPLY FIXTURE UNIT
NA	NOT APPLICABLE
UFS	UNDER FLOOR SLAB

CONCESSION PLUMBING SERVICE LINE SIZE					
SPACE TAG:	DX232	DX230A	DX226	DX218	DX203B
COLD WATER SIZE (IN.)	3/4"	1"	3/4"	1"	NA
HOT WATER SIZE (IN.)	3/4"	1"	3/4"	1"	NA
WASTE LINE SIZE (IN.)	3"	4"	3"	4"	NA

### Concession Category

- Food Service
- Services
- Convenience Retail
- Support Space
- Specialty Retail
- MAA Controlled
- Vending

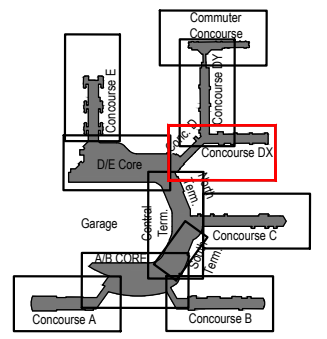
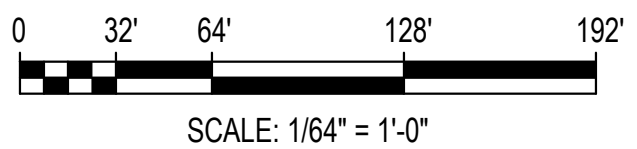

Key Plan: Airport



# Concourse DY - Upper Level (Level 2)

SPARE PLUMBING CAPACITY*			
SPACE TAG:	COLD WATER CAPACITY (WSFU)	HOT WATER CAPACITY (WSFU)	WASTE LINE CAPACITY (DFU)
DX232	NA	NA	NA
DX230A	NA	NA	NA
DX226	NA	NA	NA
DX218	NA	NA	NA
DX203B	NA	NA	NA
DY211	NA	NA	NA
DY209	NA	NA	NA
DY205	NA	NA	NA

\* REFER TO THE PLUMBING NARRATIVE FOR CAPACITY DETERMINATION AND LIMITATIONS.

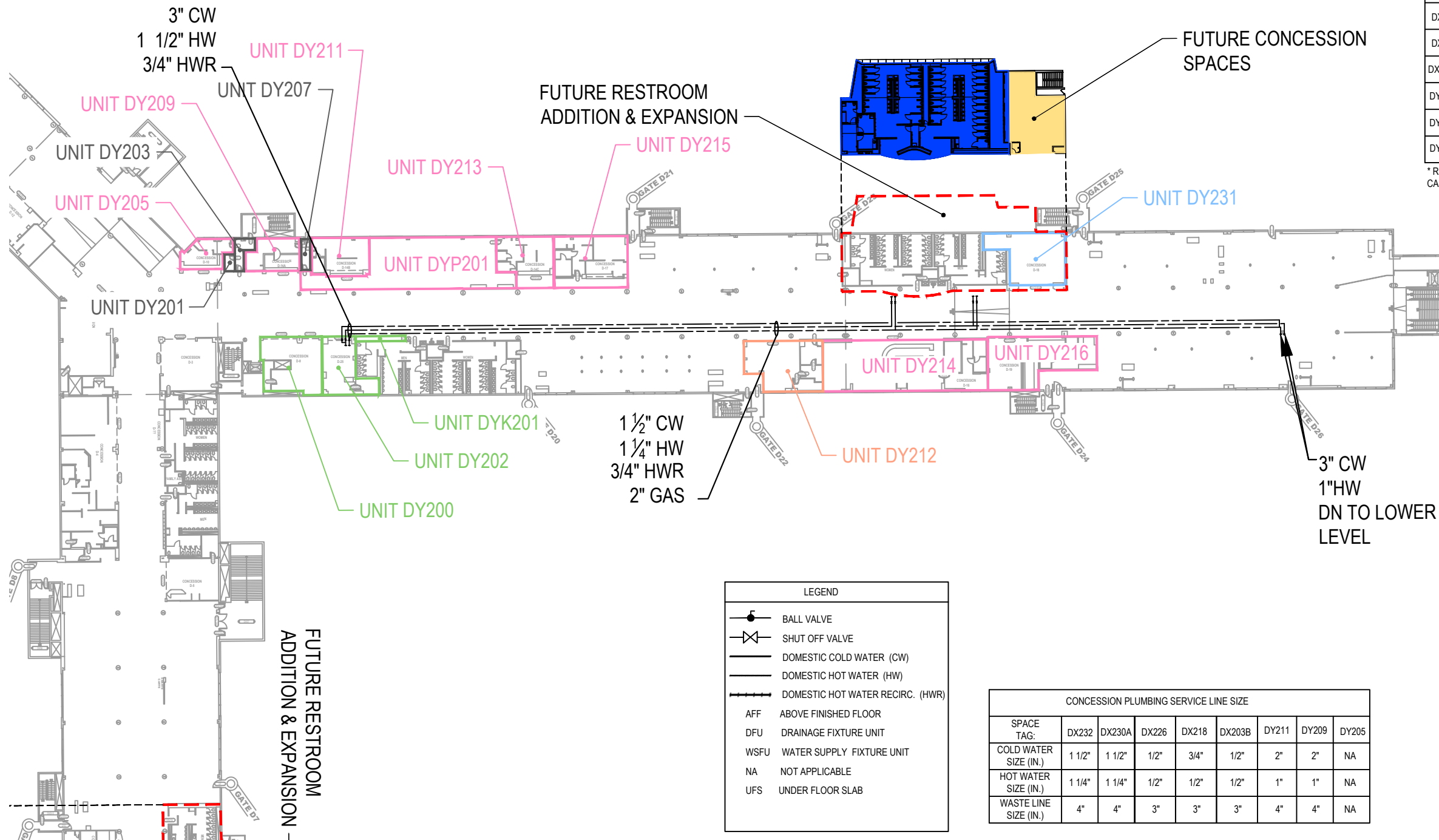

FUTURE RESTROOM ADDITION & EXPANSION

LEGEND	
	BALL VALVE
	SHUT OFF VALVE
	DOMESTIC COLD WATER (CW)
	DOMESTIC HOT WATER (HW)
	DOMESTIC HOT WATER RECIRC. (HWR)
AFF	ABOVE FINISHED FLOOR
DFU	DRAINAGE FIXTURE UNIT
WSFU	WATER SUPPLY FIXTURE UNIT
NA	NOT APPLICABLE
UFS	UNDER FLOOR SLAB

CONCESSION PLUMBING SERVICE LINE SIZE								
SPACE TAG:	DX232	DX230A	DX226	DX218	DX203B	DY211	DY209	DY205
COLD WATER SIZE (IN.)	1 1/2"	1 1/2"	1/2"	3/4"	1/2"	2"	2"	NA
HOT WATER SIZE (IN.)	1 1/4"	1 1/4"	1/2"	1/2"	1/2"	1"	1"	NA
WASTE LINE SIZE (IN.)	4"	4"	3"	3"	3"	4"	4"	NA

**Concession Category**

- Food Service
- Services
- Convenience Retail
- Support Space
- Specialty Retail
- MAA Controlled
- Vending

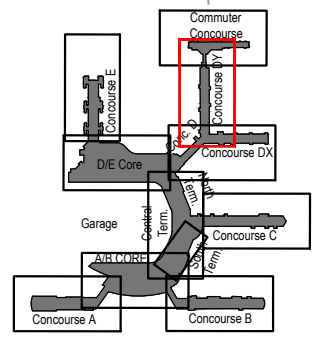

Key Plan: Airport



SCALE: 1/64" = 1'-0"

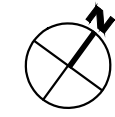

# D/E Core - Upper Level (Level 2)

LEGEND	
	BALL VALVE
	SHUT OFF VALVE
	DOMESTIC COLD WATER (CW)
	DOMESTIC HOT WATER (HW)
	DOMESTIC HOT WATER RECIRC. (HWR)
	AFF ABOVE FINISHED FLOOR
	DFU DRAINAGE FIXTURE UNIT
	WSFU WATER SUPPLY FIXTURE UNIT
	NA NOT APPLICABLE
	UFS UNDER FLOOR SLAB

SPARE PLUMBING CAPACITY*			
MAIN TYPE	MAIN SIZE	SUPPLY WATER CAPACITY (WSFU)	WASTE LINE CAPACITY (DFU)
CW	4"	20	NA
HW	3"	8	NA
SAN	6"	NA	320

SPARE PLUMBING CAPACITY*			
SPACE TAG:	COLD WATER CAPACITY (WSFU)	HOT WATER CAPACITY (WSFU)	WASTE LINE CAPACITY (DFU)
NTE260D	100	35	15
NTE260E	NA	NA	NA
EK3010	NA	NA	NA
EP3002	NA	NA	NA

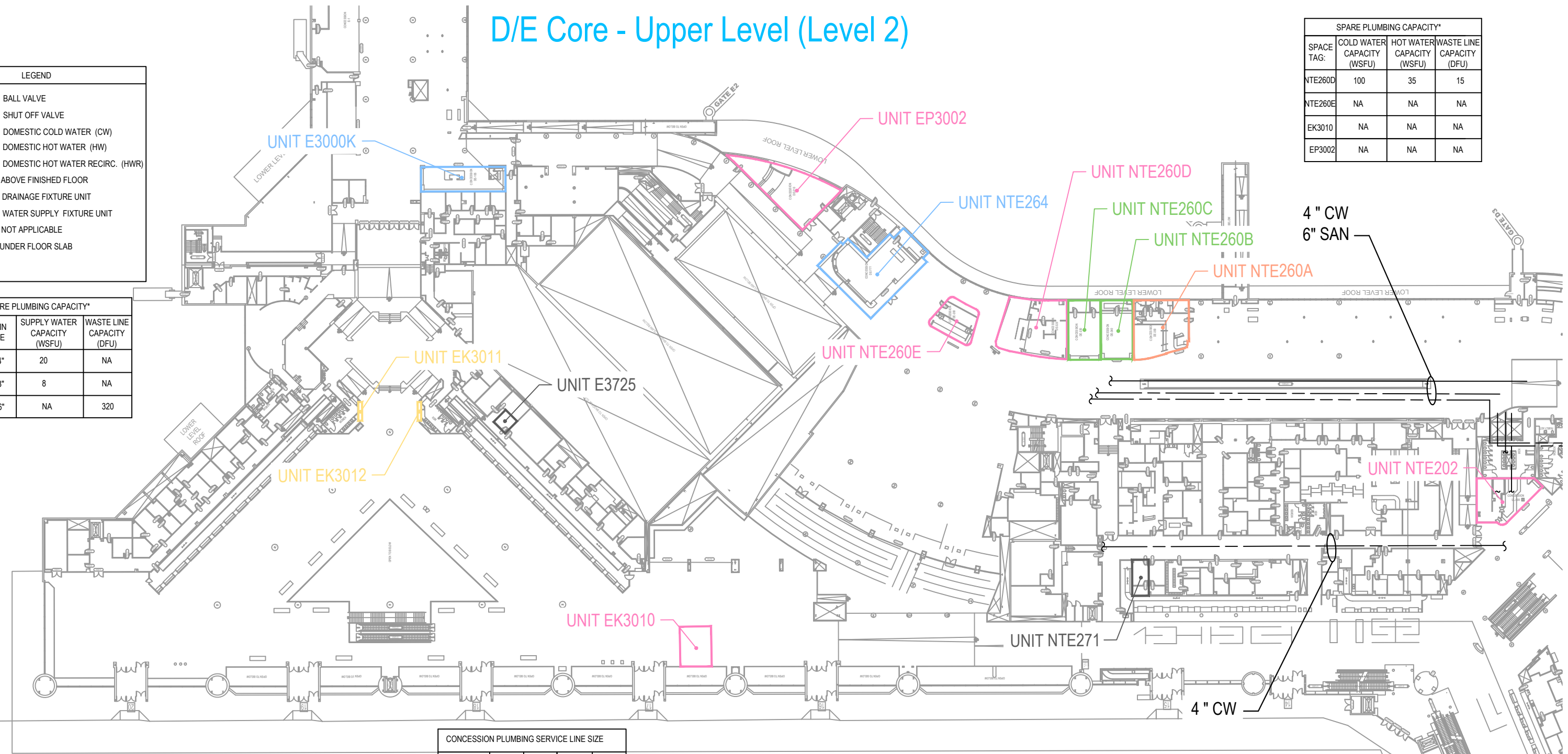

CONCESSION PLUMBING SERVICE LINE SIZE				
SPACE TAG:	NTE260D	NTE260E	EK3010	EP3002
COLD WATER SIZE (IN.)	2"	NA	NA	NA
HOT WATER SIZE (IN.)	1"	NA	NA	NA
WASTE LINE SIZE (IN.)	3"	NA	NA	NA

\* REFER TO THE PLUMBING NARRATIVE FOR CAPACITY DETERMINATION AND LIMITATIONS.

### Concession Category

- Food Service
- Convenience Retail
- Specialty Retail
- Vending
- Services
- Support Space
- MAA Controlled

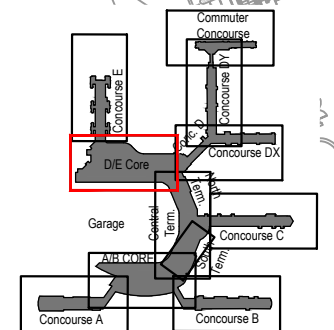

SCALE: 1/64" = 1'-0"



# Concourse E - Upper Level (Level 2)

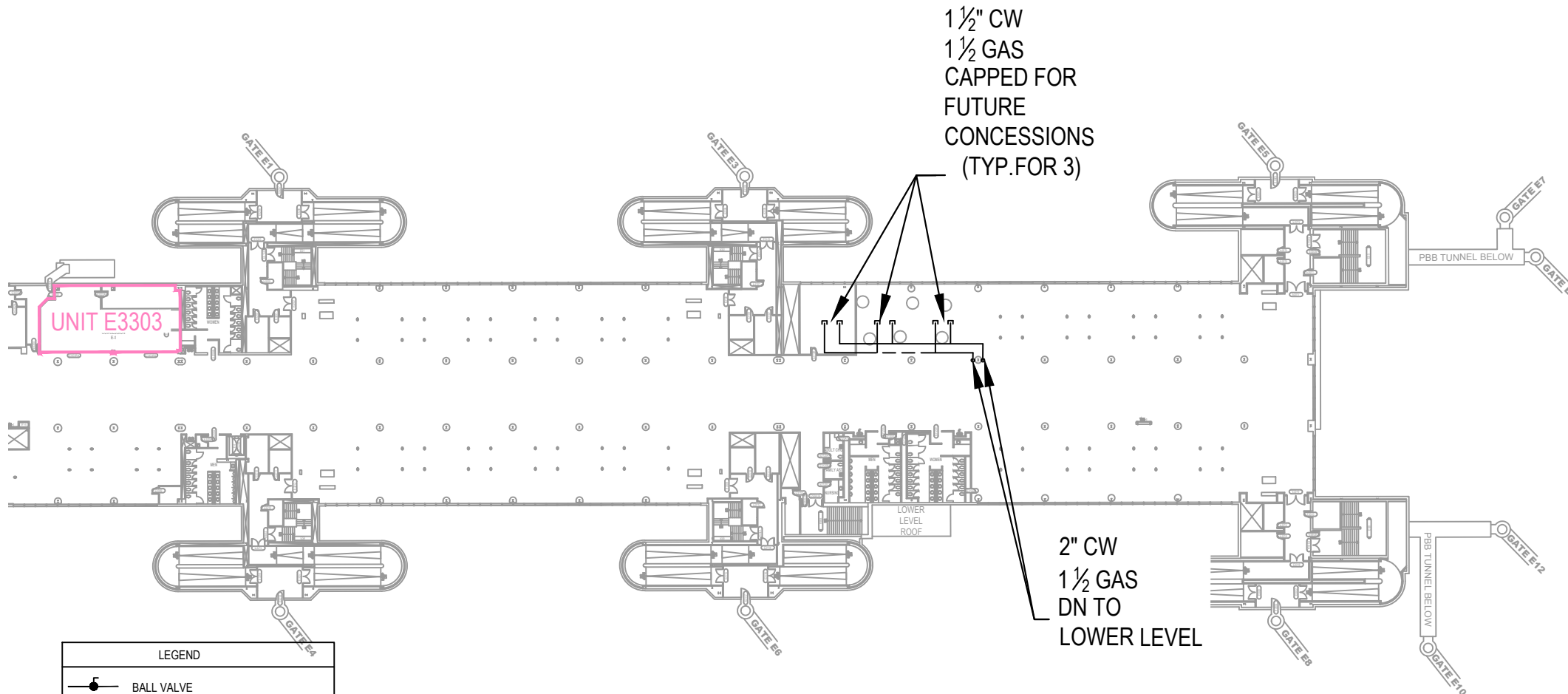

**LEGEND**

- BALL VALVE
- SHUT OFF VALVE
- DOMESTIC COLD WATER (CW)
- DOMESTIC HOT WATER (HW)
- DOMESTIC HOT WATER RECIRC. (HWR)
- AFF ABOVE FINISHED FLOOR
- DFU DRAINAGE FIXTURE UNIT
- WSFU WATER SUPPLY FIXTURE UNIT
- NA NOT APPLICABLE
- UFS UNDER FLOOR SLAB

CONCESSION PLUMBING SERVICE SIZE	
SPACE TAG:	E3303
COLD WATER SIZE (IN.)	1"
HOT WATER SIZE (IN.)	1"
WASTE LINE SIZE (IN.)	4"

SPARE PLUMBING CAPACITY*			
SPACE TAG:	COLD WATER CAPACITY (WSFU)	HOT WATER CAPACITY (WSFU)	WASTE LINE CAPACITY (DFU)
E3303	16.5	19	136

\* REFER TO THE PLUMBING NARRATIVE FOR CAPACITY DETERMINATION AND LIMITATIONS.

### Concession Category

- Food Service
- Services
- Convenience Retail
- Support Space
- Specialty Retail
- MAA Controlled
- Vending



SCALE: 1/64" = 1'-0"

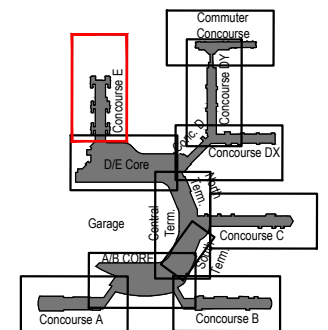

Key Plan: Airport

# Terminal Observation Gallery - Upper Level Mezzanine

SPARE PLUMBING CAPACITY*			
SPACE TAG:	COLD WATER CAPACITY (WSFU)	HOT WATER CAPACITY (WSFU)	WASTE LINE CAPACITY (DFU)
OBG10A	10	4	90

LEGEND	
	BALL VALVE
	SHUT OFF VALVE
	DOMESTIC COLD WATER (CW)
	DOMESTIC HOT WATER (HW)
	DOMESTIC HOT WATER RECIRC. (HWR)
AFF	ABOVE FINISHED FLOOR
DFU	DRAINAGE FIXTURE UNIT
WSFU	WATER SUPPLY FIXTURE UNIT
NA	NOT APPLICABLE
UFS	UNDER FLOOR SLAB

PIPE MAIN - SPARE CAPACITY - TERMINAL OBSERVATION GALLERY*			
MAIN TYPE	MAIN SIZE	SUPPLY WATER CAPACITY (WSFU)	WASTE LINE CAPACITY (DFU)
CW	2"	4	NA
HW	3"	0	NA
SAN	4"	NA	90

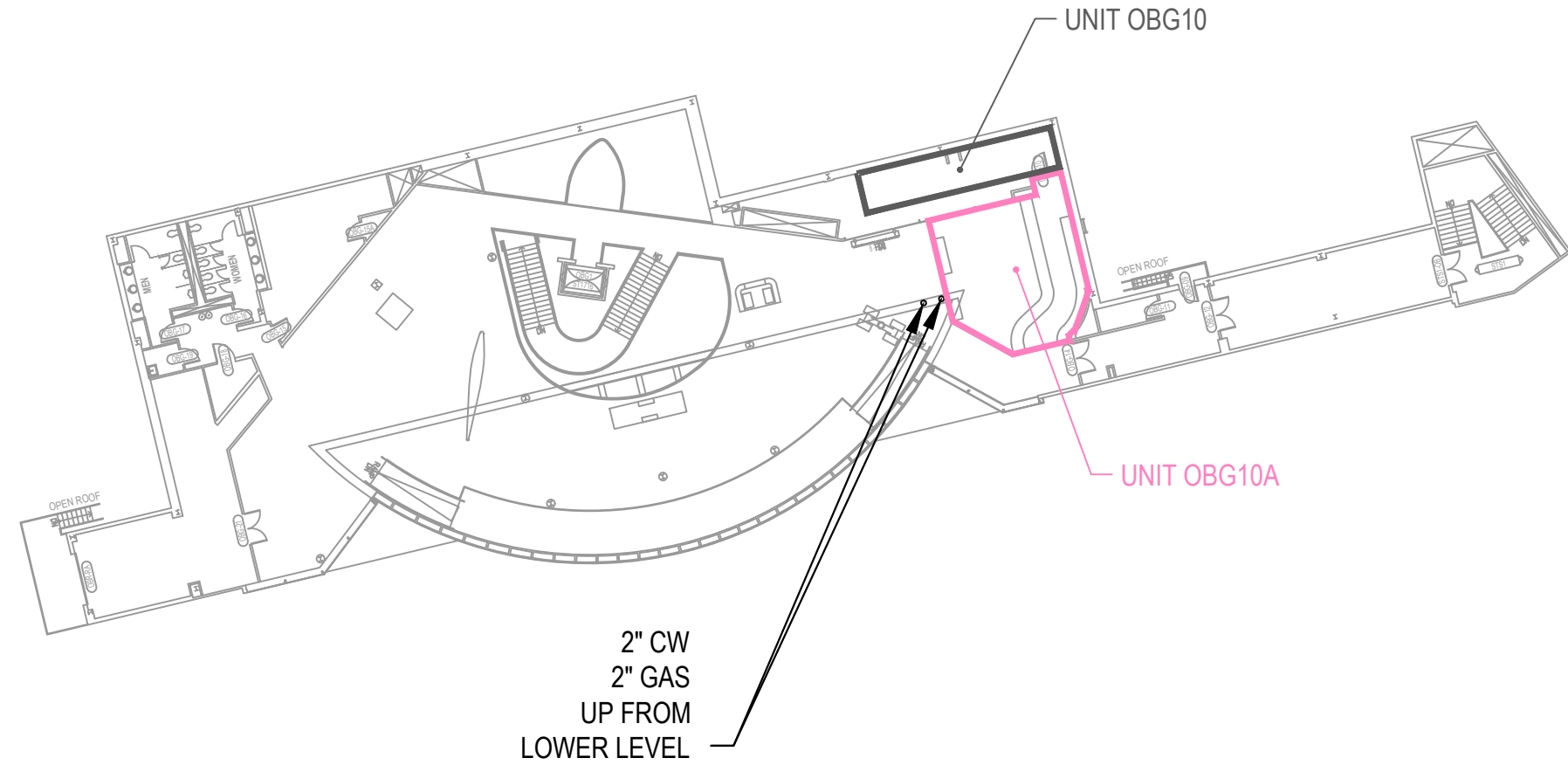

CONCESSION PLUMBING SERVICE LINE SIZE	
SPACE TAG:	OBG10A
COLD WATER SIZE (IN.)	1"
HOT WATER SIZE (IN.)	1"
WASTE LINE SIZE (IN.)	4"

\* REFER TO THE PLUMBING NARRATIVE FOR CAPACITY DETERMINATION AND LIMITATIONS.

### Concession Category

- Food Service
- Convenience Retail
- Specialty Retail
- Vending
- Services
- Support Space
- MAA Controlled

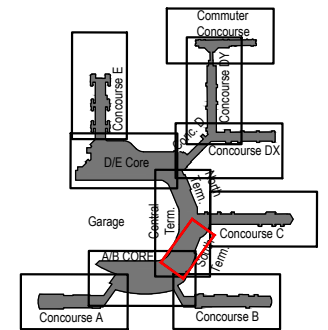

Key Plan: Airport



SCALE: 1/32" = 1'-0"





# Concourse A - Ground Level (Level 1a)

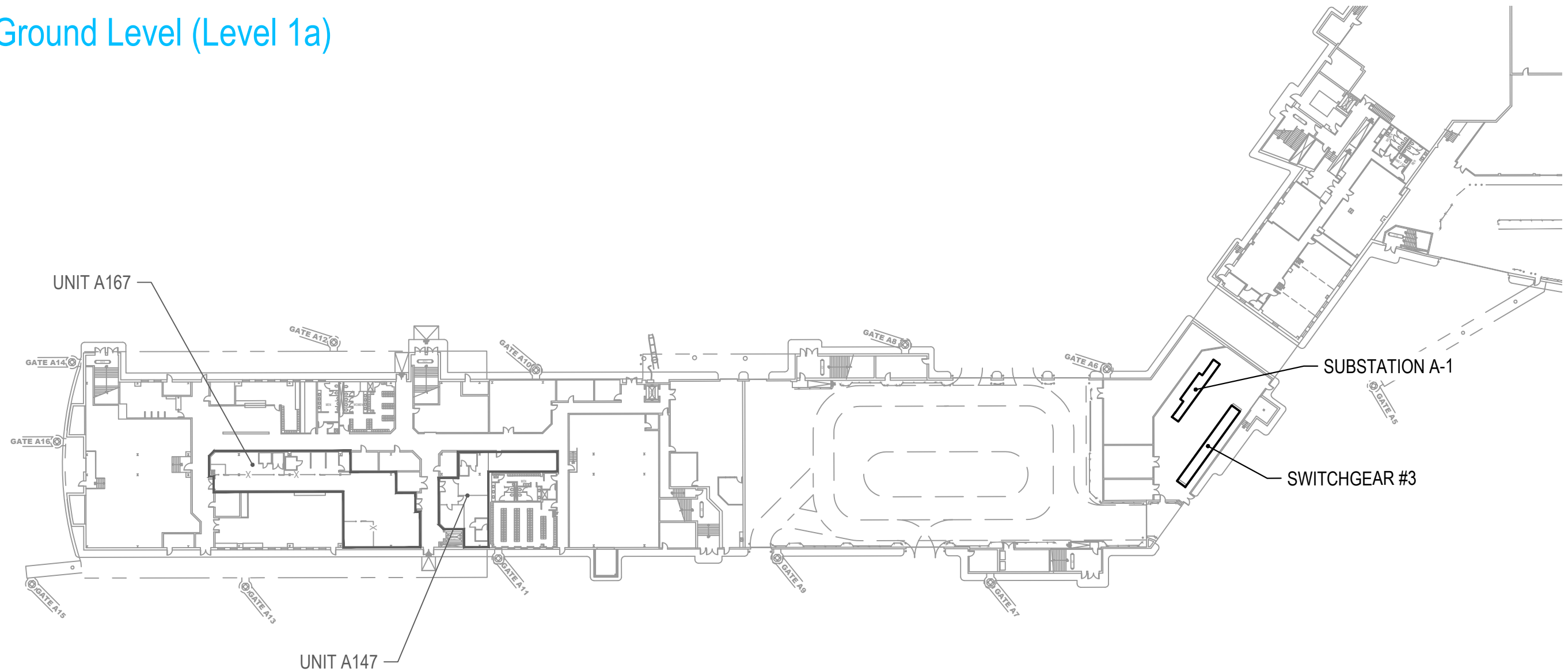

### Concession Category

- |   |                    |   |                |
|---|--------------------|---|----------------|
|  | Food Service       |  | Services       |
|  | Convenience Retail |  | Support Space  |
|  | Specialty Retail   |  | MAA Controlled |
|  | Vending            |   |                |



SCALE: 1/64" = 1'-0"

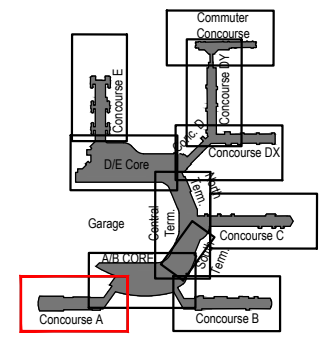

Key Plan: Airport



# A/B Core - Ground Level (Level 1a)

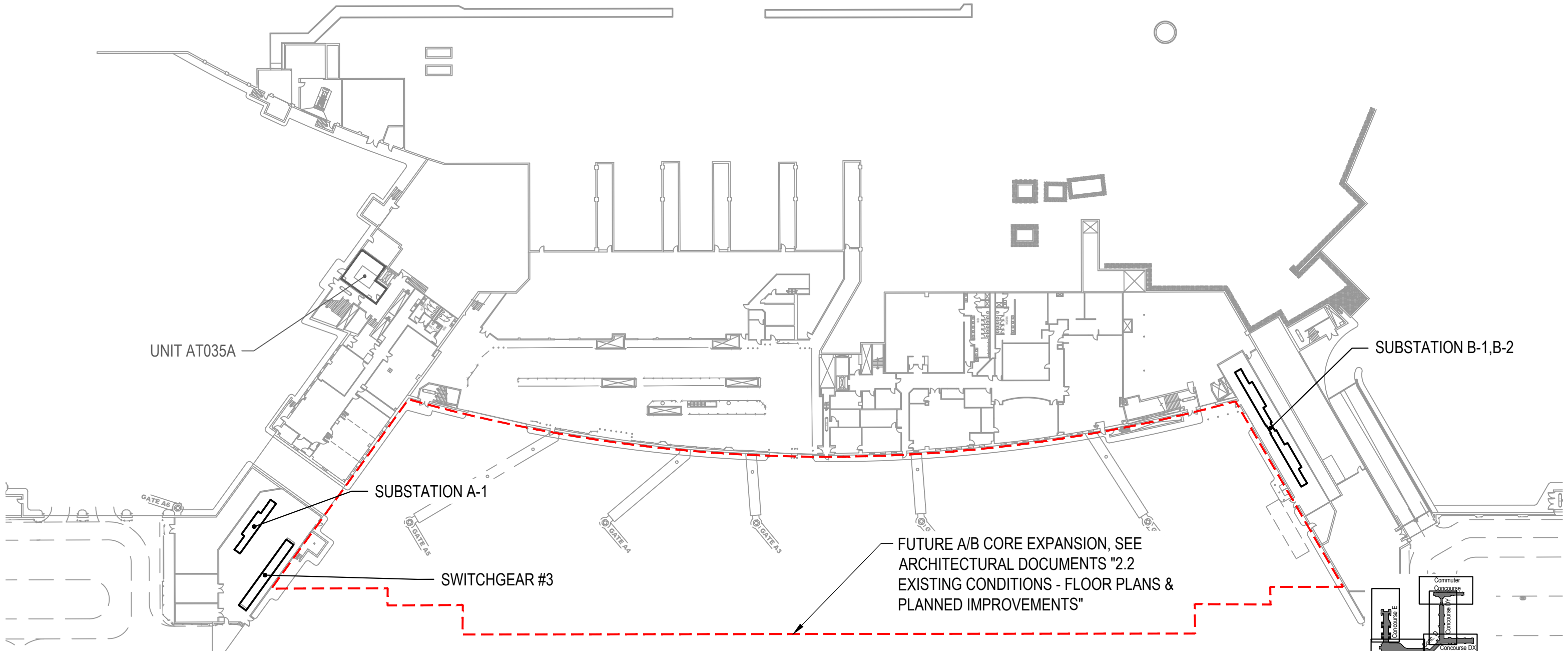

### Concession Category

- |   |                    |   |                |
|---|--------------------|---|----------------|
|  | Food Service       |  | Services       |
|  | Convenience Retail |  | Support Space  |
|  | Specialty Retail   |  | MAA Controlled |
|  | Vending            |   |                |



SCALE: 1/64" = 1'-0"

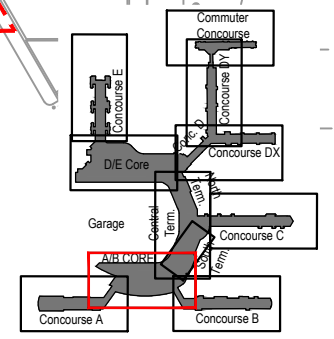

Key Plan: Airport

# Concourse B - Ground Level (Level 1a)

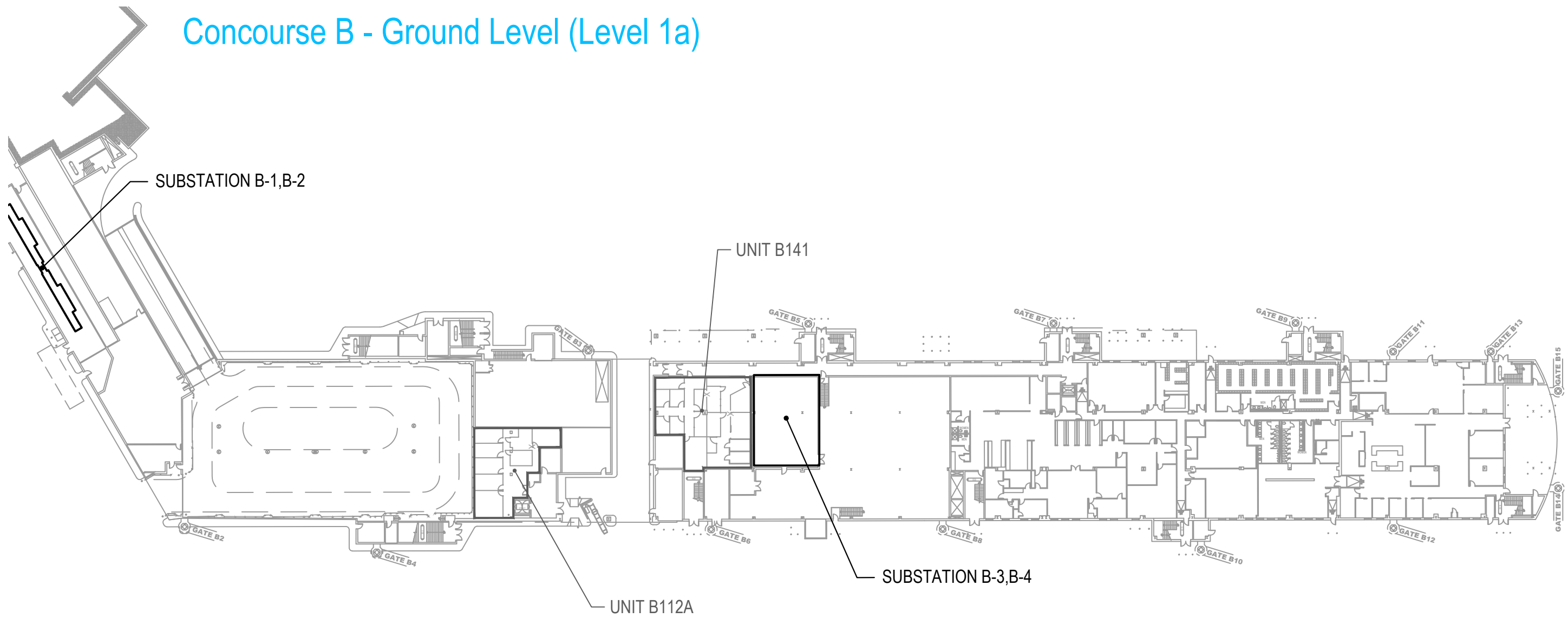

### Concession Category

- |   |                    |   |                |
|---|--------------------|---|----------------|
|  | Food Service       |  | Services       |
|  | Convenience Retail |  | Support Space  |
|  | Specialty Retail   |  | MAA Controlled |
|  | Vending            |   |                |



SCALE: 1/64" = 1'-0"

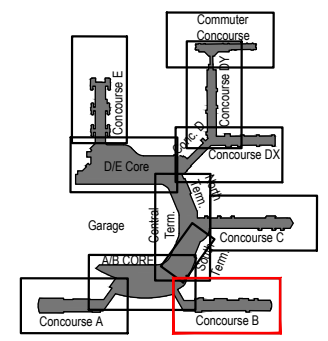

Key Plan: Airport

# A/B Core - Lower Level (Level 1)

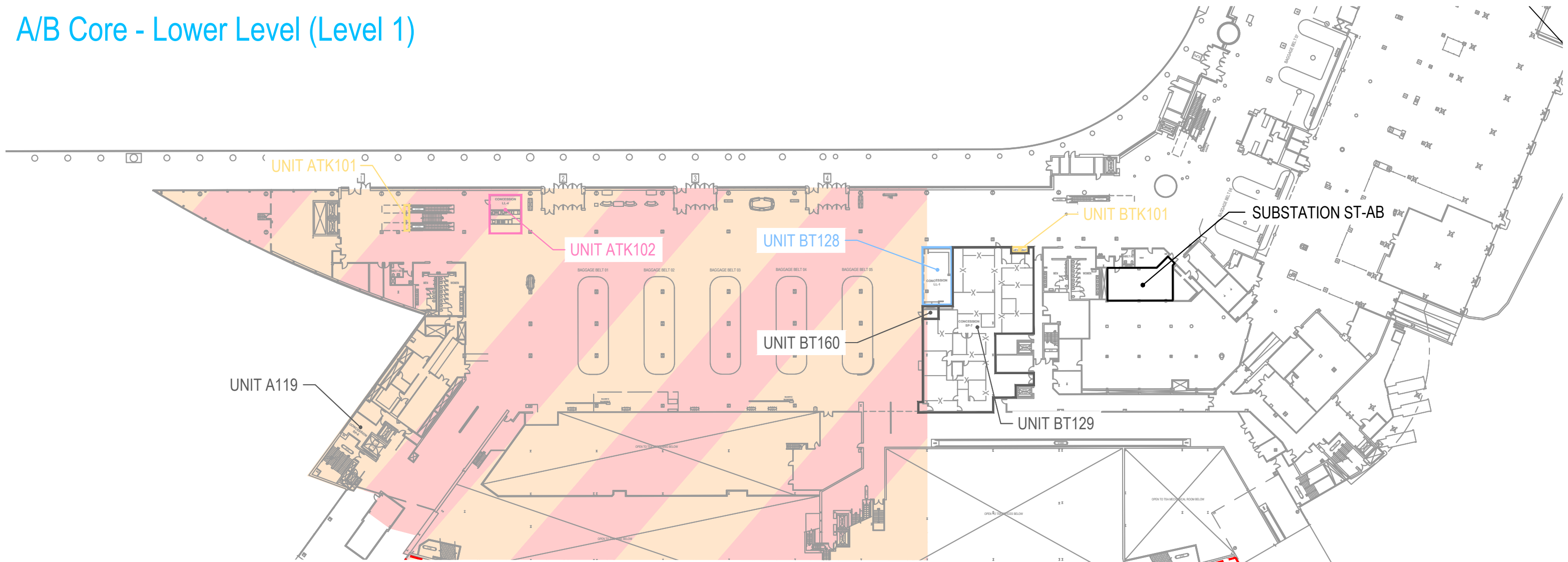

CONCESSIONS POWER SOURCE:	SUBSTATION AMPACITY/ VOLTAGE:	EXISTING PEAK DEMAND (kW-Date):	125% OF PEAK DEMAND:	REMAINING LOAD AVAILABLE (kVA):	50% AVAILABLE FOR CONCESSIONS (kVA):
SUBSTATION A-1	4000A / 480V	1728kW - DATE N/A	2160kW	920kVA	460kVA
SUBSTATION B-2	4000A / 480V	638kW - DATE N/A	798kW	2430kVA	1215kVA
*SUBST. ST-AB	3000A / 480V	350-500kW - DATE N/A	625kW	1970kVA	985kVA

\*THE AREAS SERVED BY SUBSTATION ST-AB ARE UNKNOWN.

### Concession Category

- Food Service
- Convenience Retail
- Specialty Retail
- Vending
- Services
- Support Space
- MAA Controlled

FUTURE A/B CORE EXPANSION, SEE ARCHITECTURAL DOCUMENTS "2.2 EXISTING CONDITIONS - FLOOR PLANS & PLANNED IMPROVEMENTS"

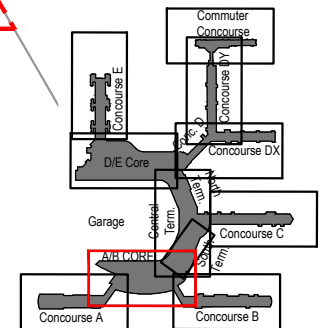



Key Plan: Airport



SCALE: 1/64" = 1'-0"



# Terminal South, Center, North - Lower Level (Level 1)

CONCESSIONS POWER SOURCE:	SUBSTATION AMPACITY/VOLTAGE:	EXISTING PEAK DEMAND (kW-Date):	125% OF PEAK DEMAND:	REMAINING LOAD AVAILABLE (kVA):	50% AVAILABLE FOR CONCESSIONS (kVA):
 SUBSTATION NT-D	4000A / 480V	749kW - 10/15	936kW	2280kVA	1140kVA
 SUBSTATION NT-D1	4000A / 480V	557kW - 10/17	696kW	2550kVA	1275kVA

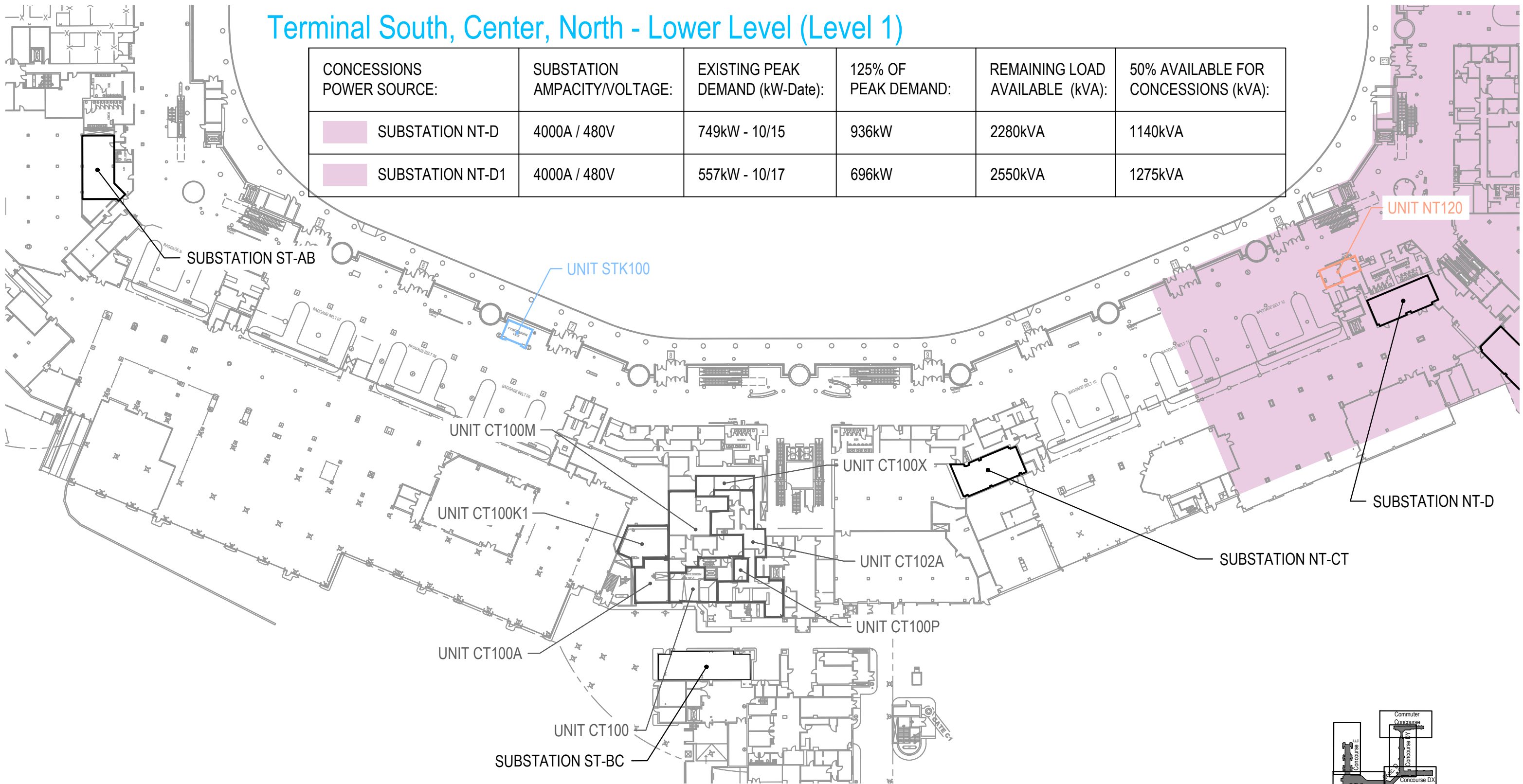

### Concession Category

-  Food Service
-  Convenience Retail
-  Specialty Retail
-  Vending
-  Services
-  Support Space
-  MAA Controlled

0 32' 64' 128' 192'



SCALE: 1/64" = 1'-0"

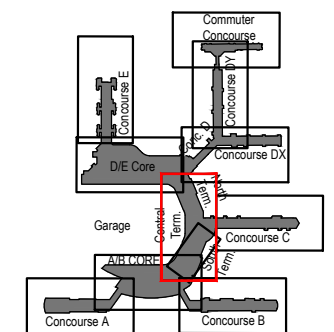

Key Plan: Airport



# Concourse C - Lower Level (Level 1)

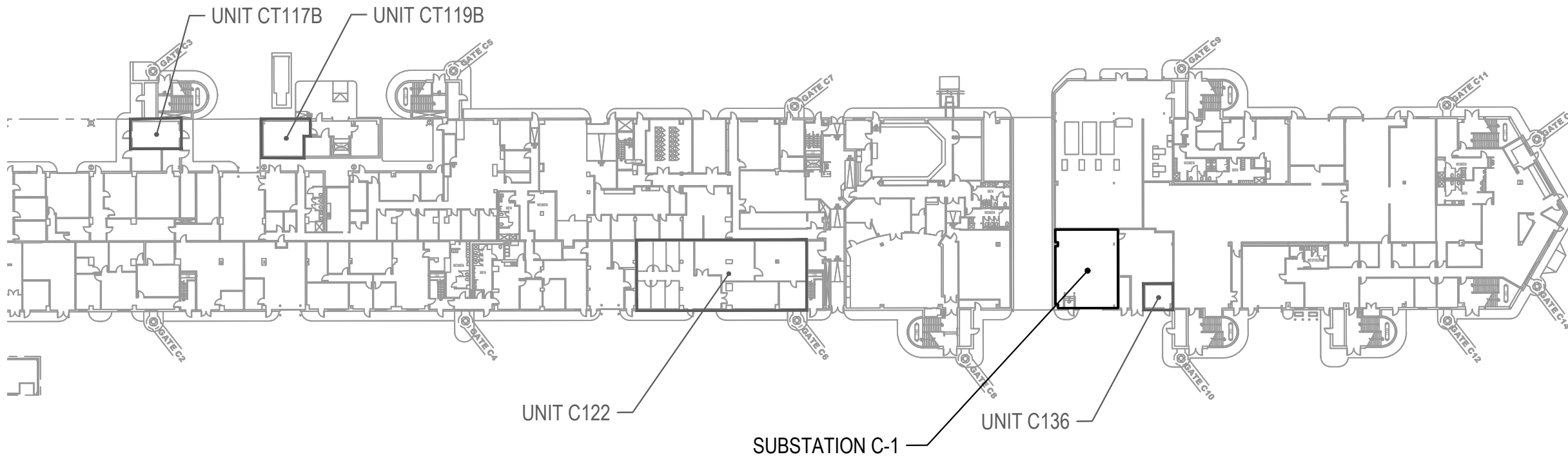

## Concession Category

- |   |                    |   |                |
|---|--------------------|---|----------------|
|  | Food Service       |  | Services       |
|  | Convenience Retail |  | Support Space  |
|  | Specialty Retail   |  | MAA Controlled |
|  | Vending            |   |                |



SCALE: 1/64" = 1'-0"

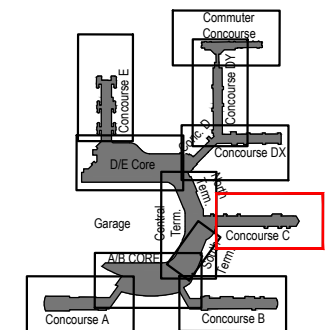

Key Plan: Airport

# Concourse D, DX - Lower Level (Level 1)

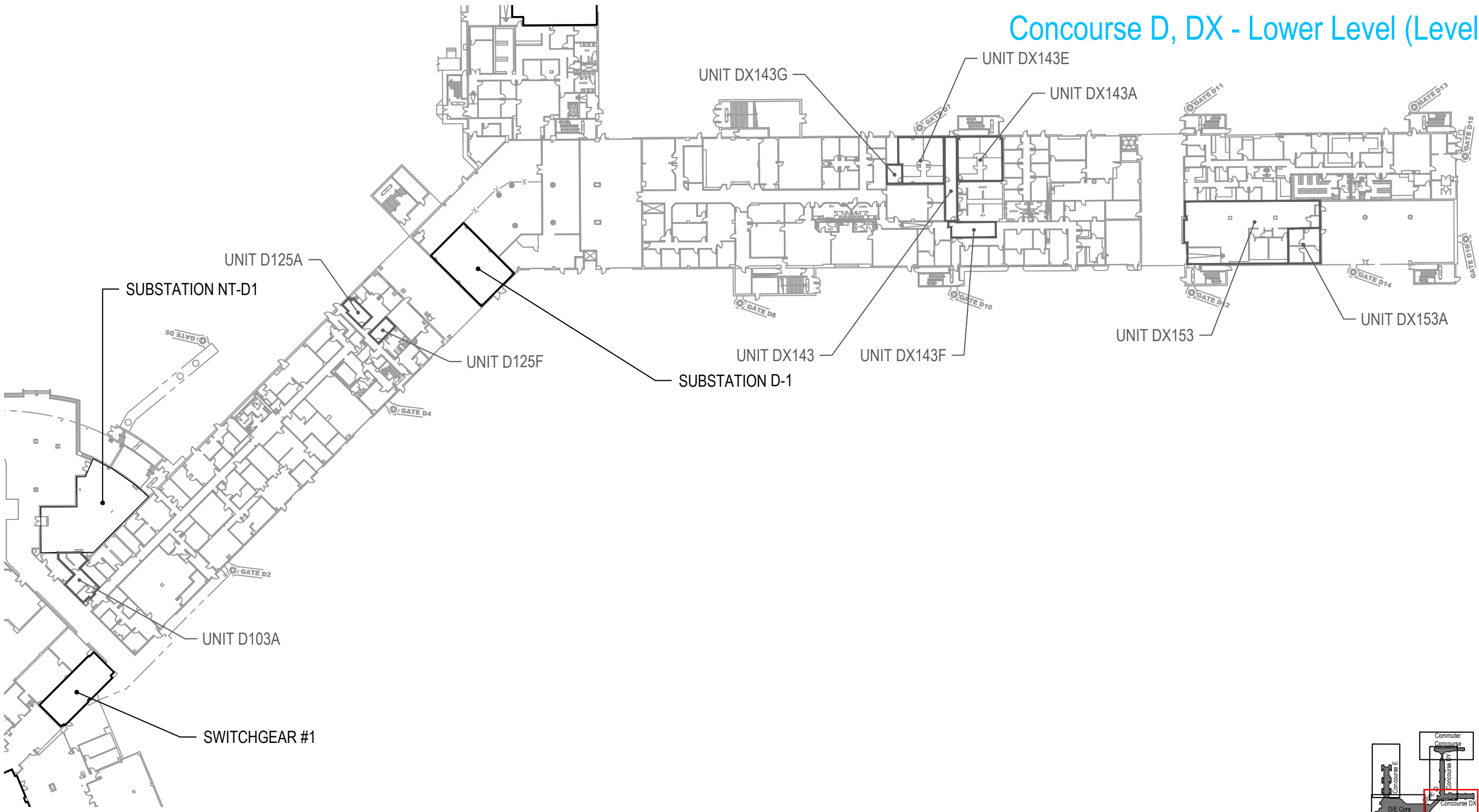

- Concession Category
- Food Service
  - Convenience Retail
  - Specialty Retail
  - Services
  - Support Space
  - MAA Controlled
  - Vending

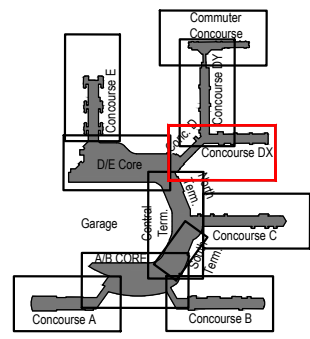
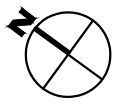
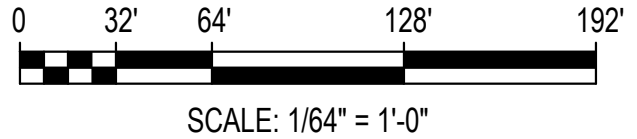

Key Plan: Airport

# Concourse DY - Lower Level (Level 1)

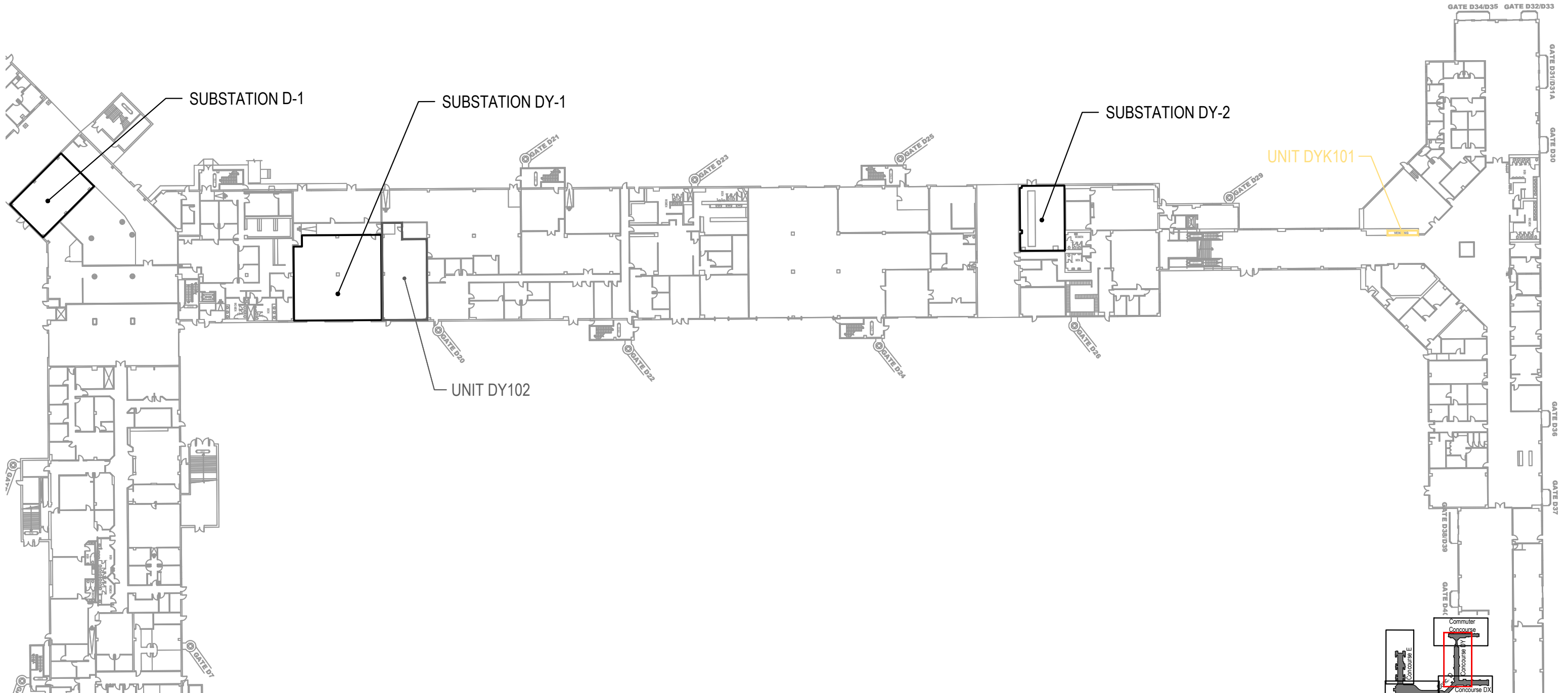

**Concession Category**

- |   |  |
|---|--|
| <span style="border: 1px solid pink; display: inline-block; width: 15px; height: 10px;"></span> Food Service            | <span style="border: 1px solid orange; display: inline-block; width: 15px; height: 10px;"></span> Services       |
| <span style="border: 1px solid lightblue; display: inline-block; width: 15px; height: 10px;"></span> Convenience Retail | <span style="border: 1px solid gray; display: inline-block; width: 15px; height: 10px;"></span> Support Space    |
| <span style="border: 1px solid green; display: inline-block; width: 15px; height: 10px;"></span> Specialty Retail       | <span style="border: 1px solid purple; display: inline-block; width: 15px; height: 10px;"></span> MAA Controlled |
| <span style="border: 1px solid yellow; display: inline-block; width: 15px; height: 10px;"></span> Vending               |  |

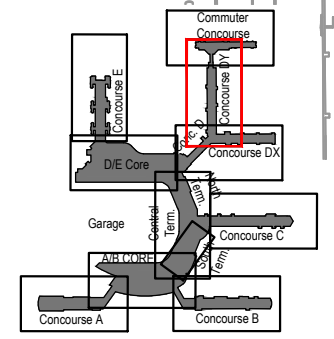

Key Plan: Airport



SCALE: 1/64" = 1'-0"

# Commuter Concourse D - Lower Level (Level 1)

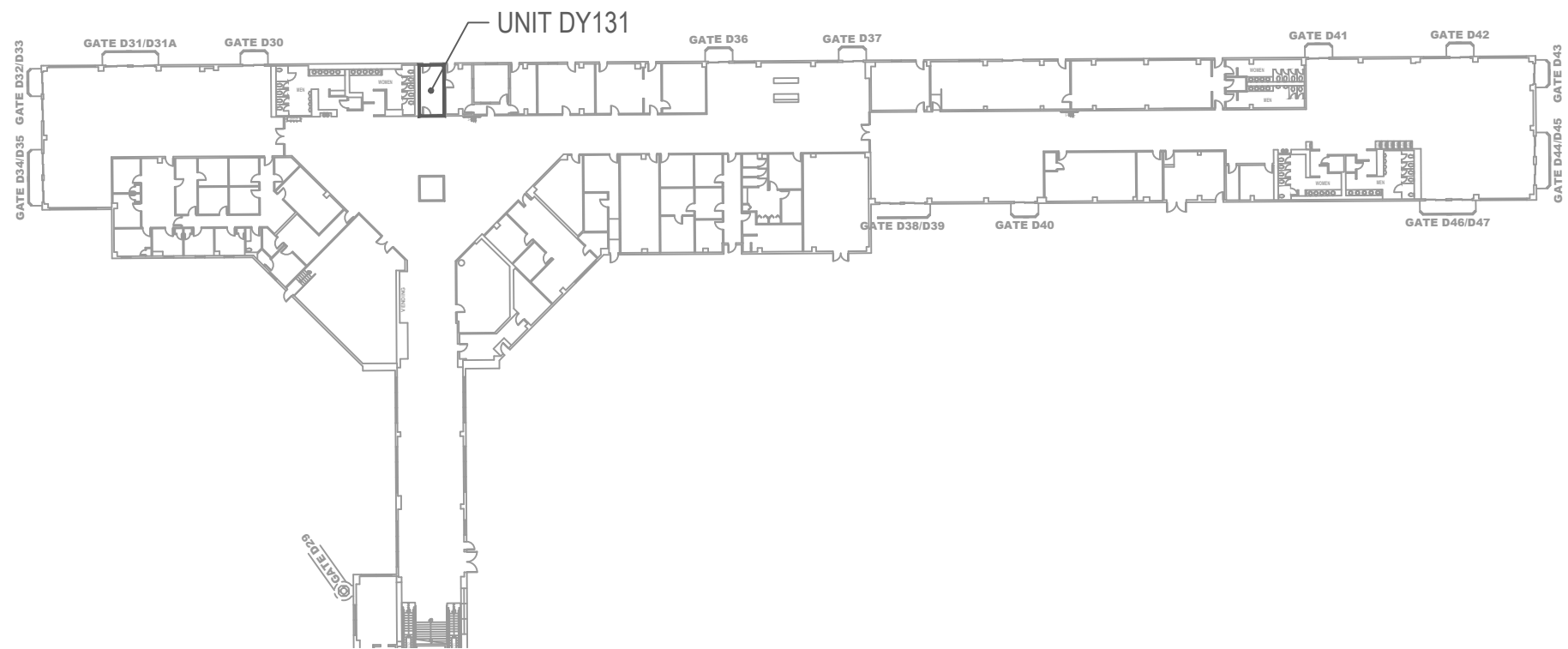

## Concession Category

- |   |                    |   |                |
|---|--------------------|---|----------------|
|  | Food Service       |  | Services       |
|  | Convenience Retail |  | Support Space  |
|  | Specialty Retail   |  | MAA Controlled |
|  | Vending            |   |                |



SCALE: 1/64" = 1'-0"

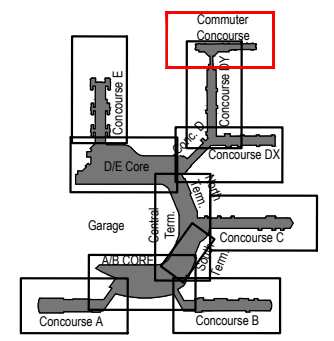

Key Plan: Airport



# D/E Core - Lower Level (Level 1)

CONCESSIONS POWER SOURCE:	SUBSTATION AMPACITY/VOLTAGE:	EXISTING PEAK DEMAND (kW-Date):	125% OF PEAK DEMAND:	REMAINING LOAD AVAILABLE (kVA):	50% AVAILABLE FOR CONCESSIONS (kVA):
 SUBSTATION E-1	4000A / 480V	1186kW - DATE N/A	1483kW	1670kVA	835kVA

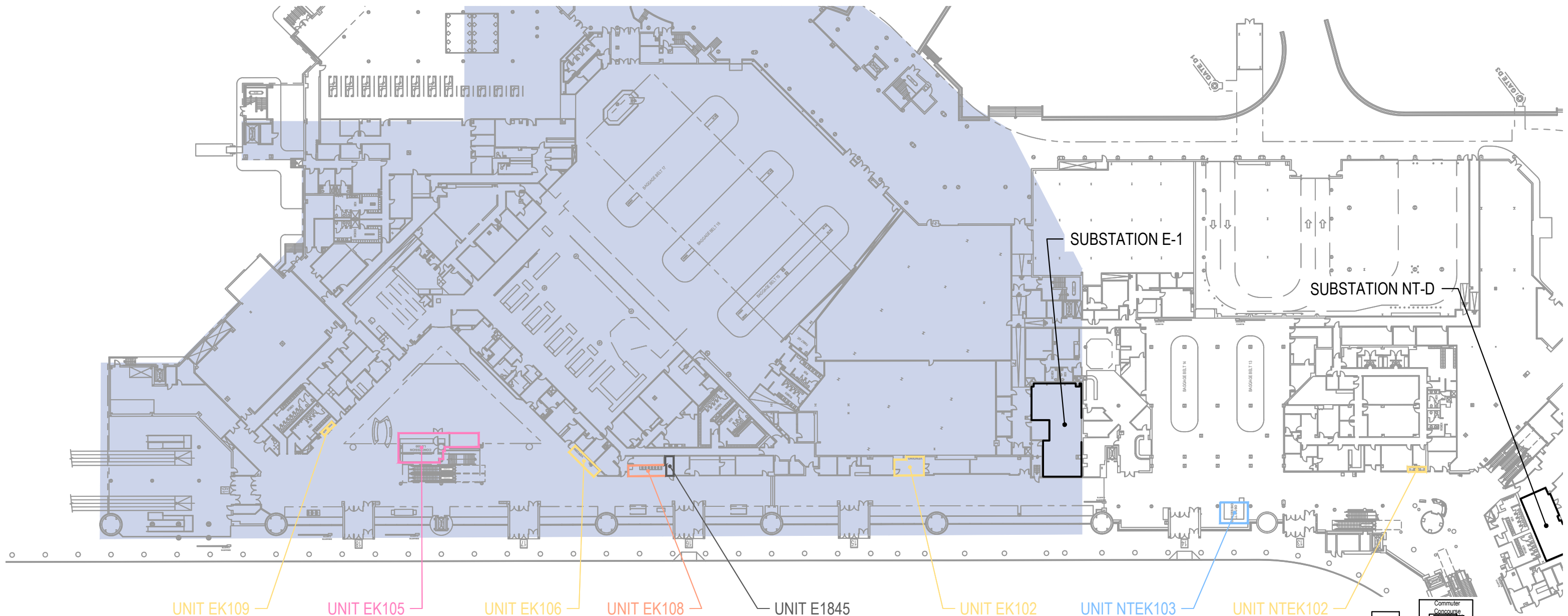

### Concession Category

-  Food Service
-  Convenience Retail
-  Specialty Retail
-  Vending
-  Services
-  Support Space
-  MAA Controlled



SCALE: 1/64" = 1'-0"

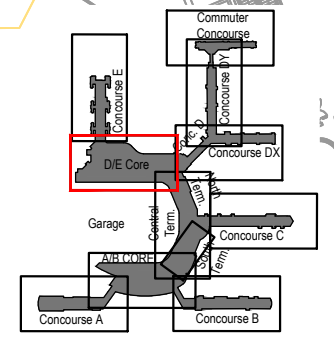

Key Plan: Airport

# Concourse E - Lower Level (Level 1)

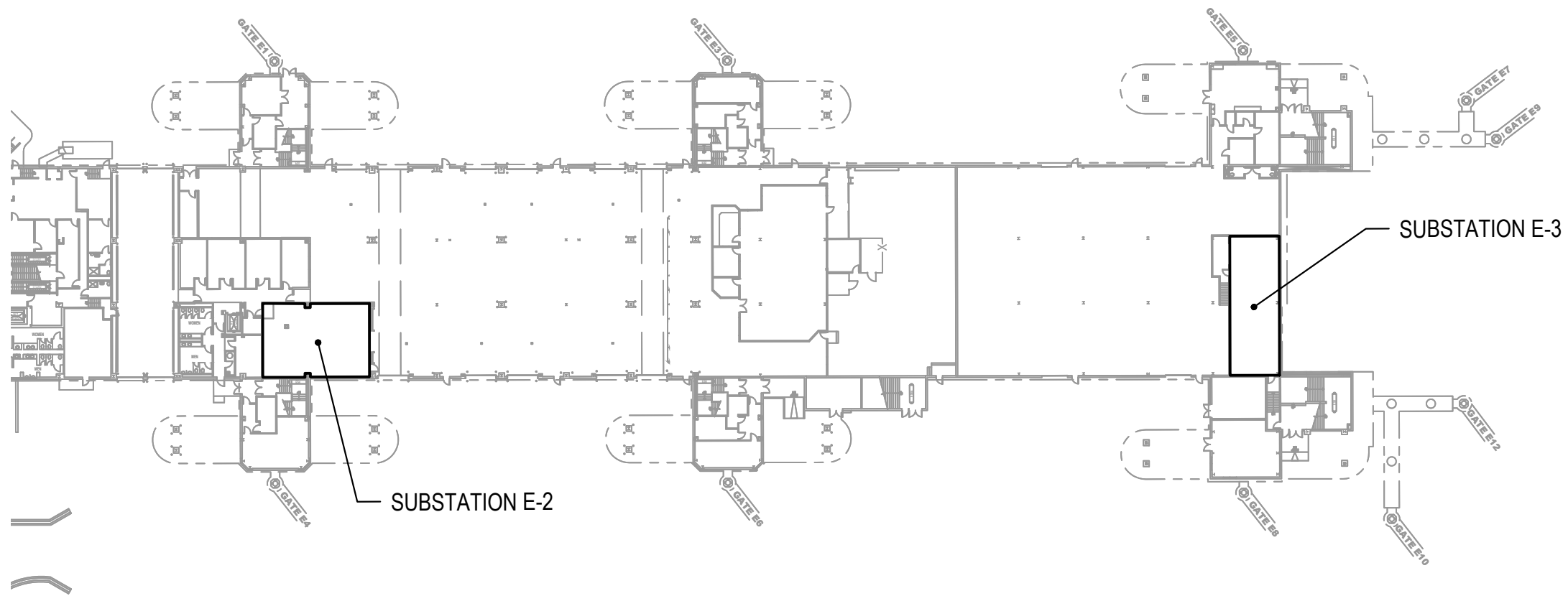

ITE E2

### Concession Category

- |   |                    |   |                |
|---|--------------------|---|----------------|
|  | Food Service       |  | Services       |
|  | Convenience Retail |  | Support Space  |
|  | Specialty Retail   |  | MAA Controlled |
|  | Vending            |   |                |



SCALE: 1/64" = 1'-0"

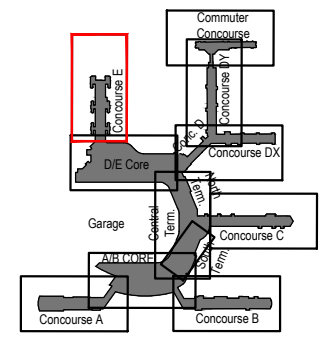

Key Plan: Airport

# Concourse A - Upper Level (Level 2)

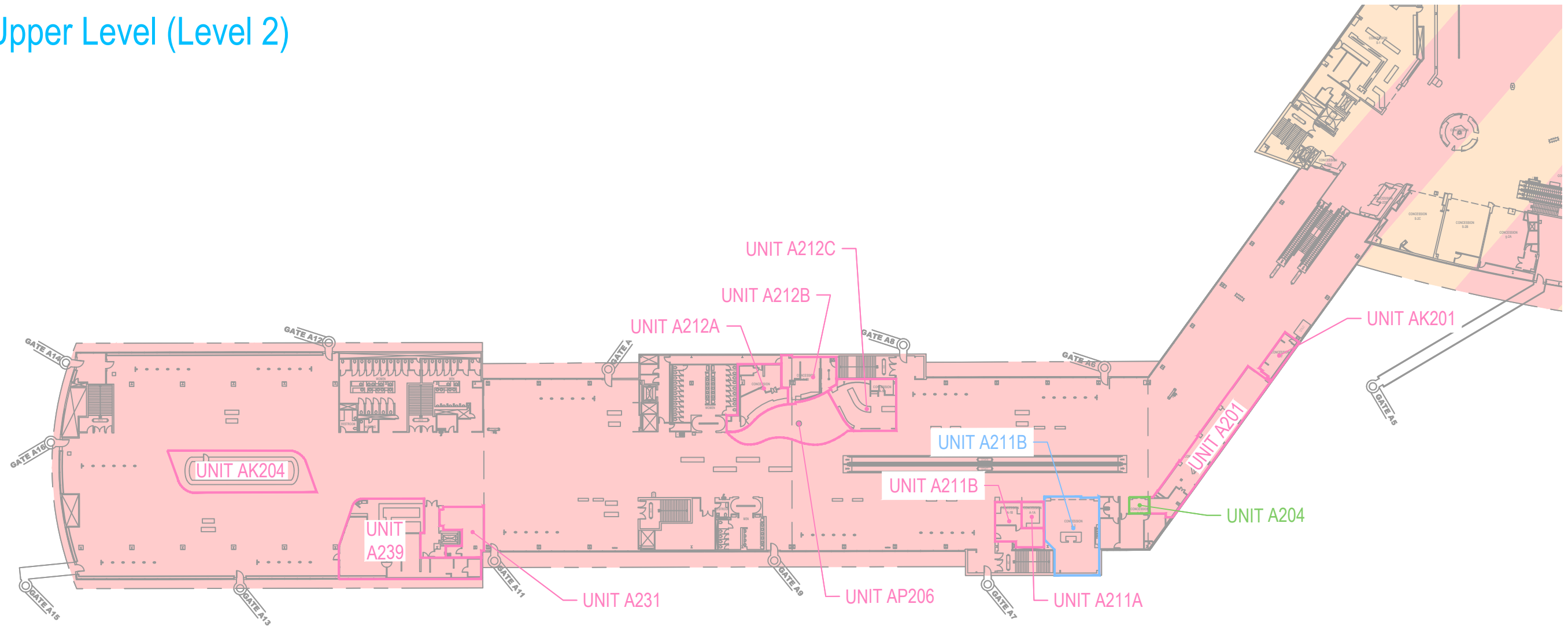

CONCESSIONS POWER SOURCE:	SUBSTATION AMPACITY/VOLTAGE:	EXISTING PEAK DEMAND (kW-Date):	125% OF PEAK DEMAND:	REMAINING LOAD AVAILABLE (kVA):	50% AVAILABLE FOR CONCESSIONS (kVA):
<span style="display:inline-block; width:15px; height:15px; background-color:#f8d7da;"></span> SUBSTATION A-1	4000A / 480V	1728kW - DATE N/A	2160kW	920kVA	460kVA
<span style="display:inline-block; width:15px; height:15px; background-color:#fff3cd;"></span> SUBSTATION B-2	4000A / 480V	638kW - DATE N/A	798kW	2430kVA	1215kVA

### Concession Category

- Food Service
- Convenience Retail
- Specialty Retail
- Vending
- Services
- Support Space
- MAA Controlled



SCALE: 1/64" = 1'-0"

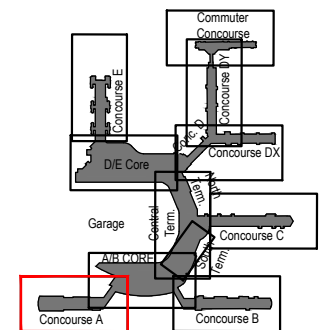

Key Plan: Airport

# A/B Core - Upper Level (Level 2)

\*THE AREAS SERVED BY SUBSTATION ST-AB ARE UNKNOWN.

CONCESSIONS POWER SOURCE:	SUBSTATION AMPACITY/ VOLTAGE:	EXISTING PEAK DEMAND (kW-Date):	125% OF PEAK DEMAND:	REMAINING LOAD AVAILABLE (kVA):	50% AVAILABLE FOR CONCESSIONS (kVA):
SUBSTATION A-1	4000A / 480V	1728kW - DATE N/A	2160kW	920kVA	460kVA
SUBSTATION B-1	4000A / 480V	1075kW - DATE N/A	1344kW	1830kVA	915kVA
SUBSTATION B-2	4000A / 480V	638kW - DATE N/A	798kW	2430kVA	1215kVA
*SUBST. ST-AB	3000A / 480V	350-500kW - DATE N/A	625kW	1970kVA	985kVA

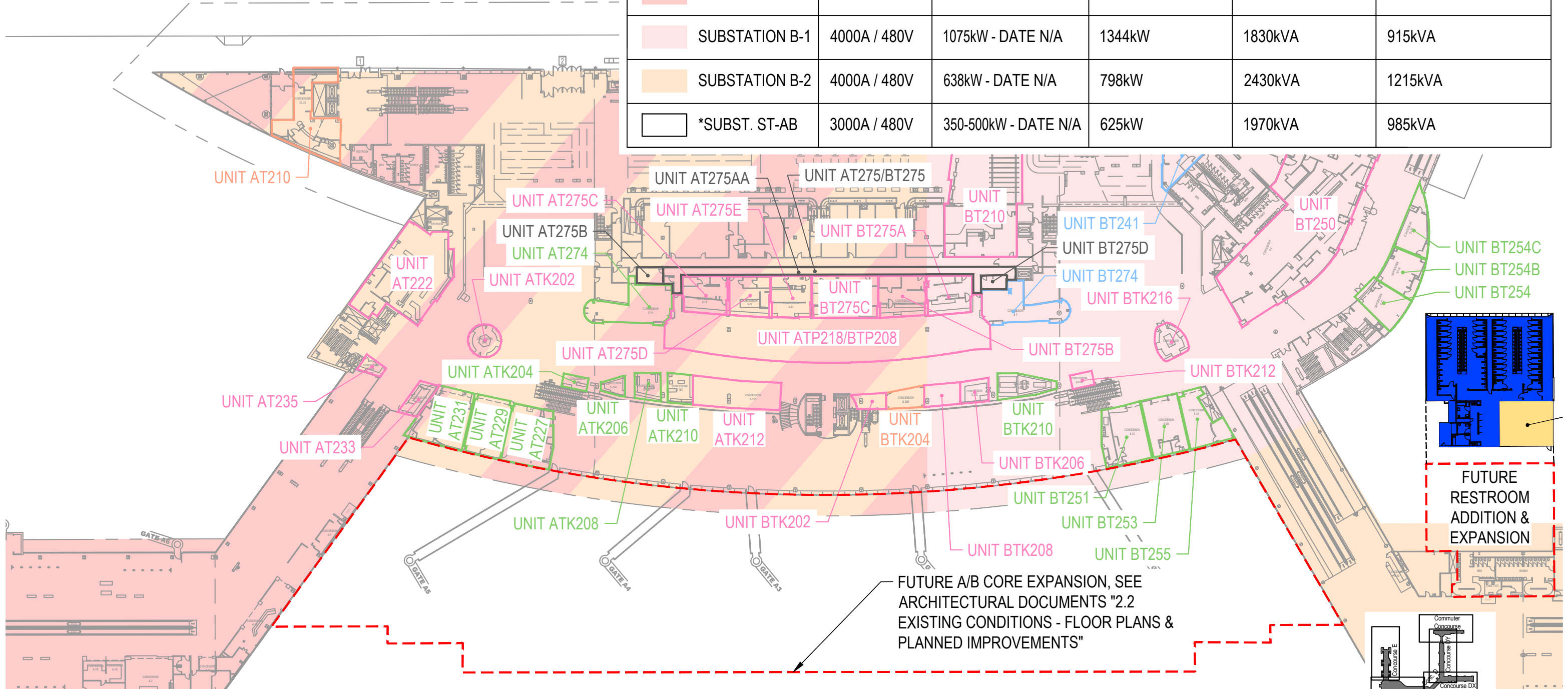

**Concession Category**

Food Service	Services
Convenience Retail	Support Space
Specialty Retail	MAA Controlled
Vending	

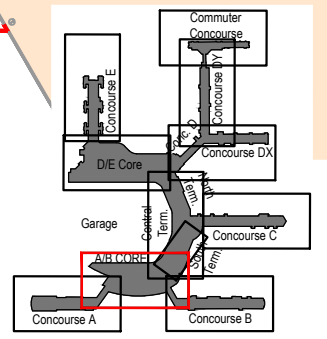
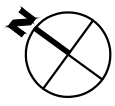
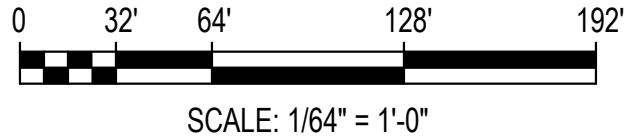



# Concourse B - Upper Level (Level 2)

\* INDIVIDUAL PEAK DEMAND FOR SUBSTATION B-3 AND B-4 NOT AVAILABLE. PEAK DEMAND FROM UPSTREAM SWITCHGEAR #3 BREAKER S31 AND ASSUMED EVEN LOAD BETWEEN THE TWO SUBSTATIONS.  
 FUTURE CONCESSION SPACES  
 FUTURE RESTROOM ADDITION & EXPANSION

CONCESSIONS POWER SOURCE:	SUBSTATION AMPACITY/VOLTAGE:	EXISTING PEAK DEMAND (kW-Date):	125% OF PEAK DEMAND:	REMAINING LOAD AVAILABLE (kVA):	50% AVAILABLE FOR CONCESSIONS (kVA):
SUBSTATION B-1	4000A / 480V	1075kW - DATE N/A	1344kW	1830kVA	915kVA
SUBSTATION B-2	4000A / 480V	638kW - DATE N/A	798kW	2430kVA	1215kVA
SUBSTATION B-3	4000A / 480V	818kW* - DATE N/A	1023kW	360kVA	180kVA
SUBSTATION B-4	4000A / 480V	818kW* - DATE N/A	1023kW	360kVA	180kVA

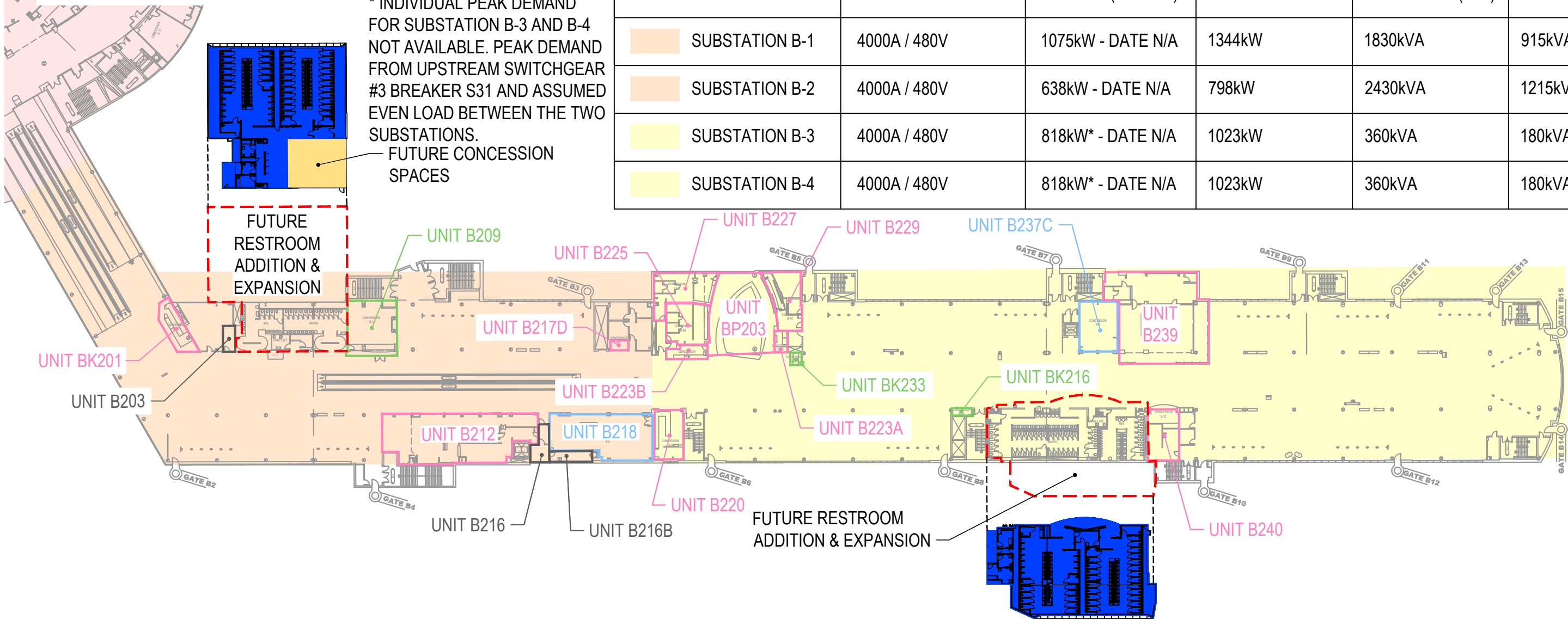

### Concession Category

- Food Service
- Services
- Convenience Retail
- Support Space
- Specialty Retail
- MAA Controlled
- Vending



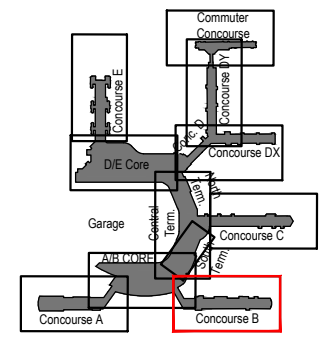

SCALE: 1/64" = 1'-0"



Key Plan: Airport

# Terminal South, Center, North - Upper Level (Level 2)

CONCESSIONS POWER SOURCE:	SUBSTATION AMPACITY/VOLTAGE:	EXISTING PEAK DEMAND (kW-Date):	125% OF PEAK DEMAND:	REMAINING LOAD AVAILABLE (kVA):	50% AVAILABLE FOR CONCESSIONS (kVA):
 SUBSTATION ST-BC	4000A / 480V	707kW - 07/21	884kW	2340kVA	1170kVA
 SUBSTATION NT-CT	4000A / 480V	579kW - 07/20	724kW	2520kVA	1260kVA
 SUBSTATION NT-D	4000A / 480V	749kW - 10/15	696kW	2550kVA	1275kVA

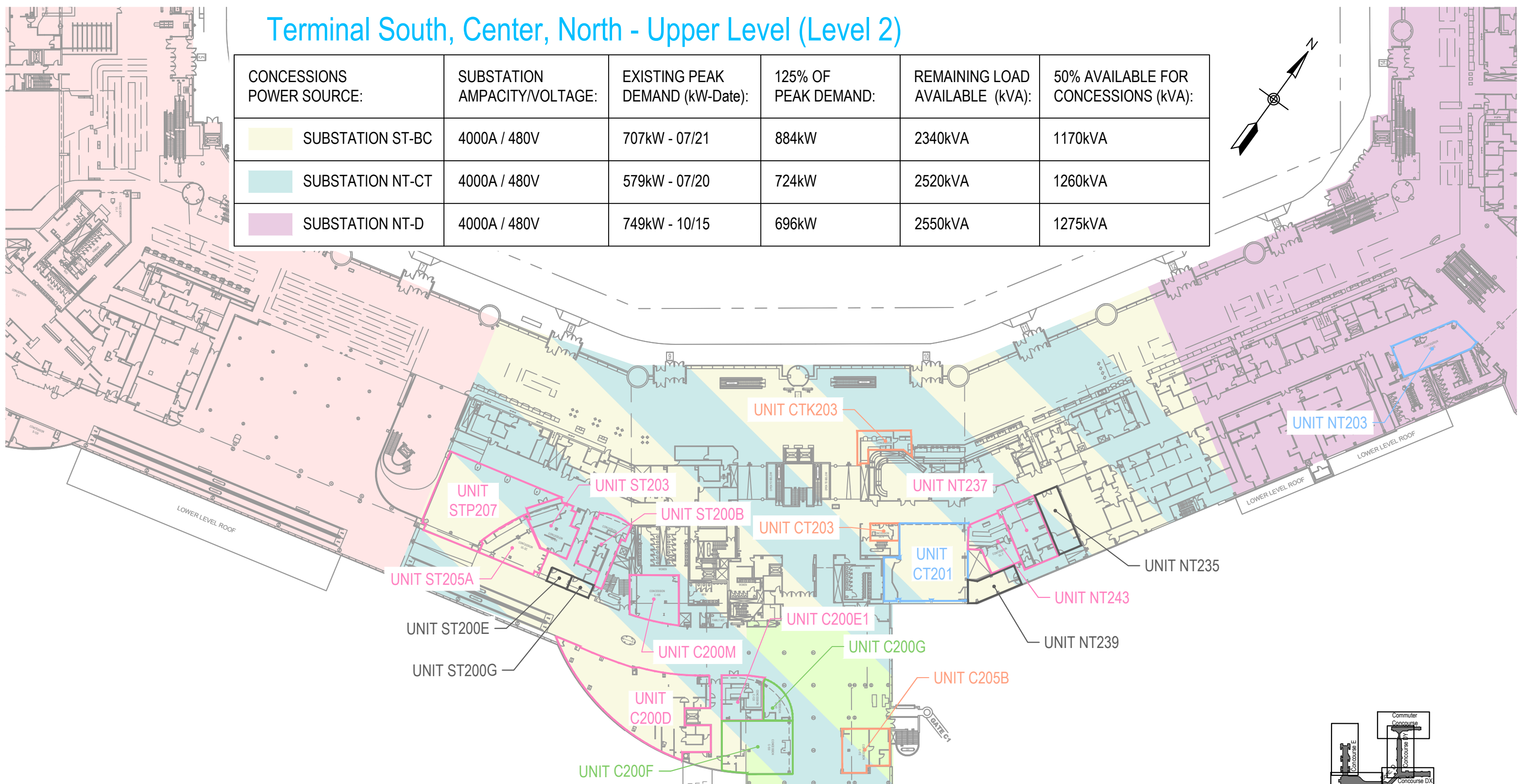
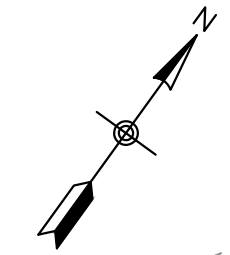

### Concession Category

-  Food Service
-  Convenience Retail
-  Specialty Retail
-  Vending
-  Services
-  Support Space
-  MAA Controlled



SCALE: 1/64" = 1'-0"

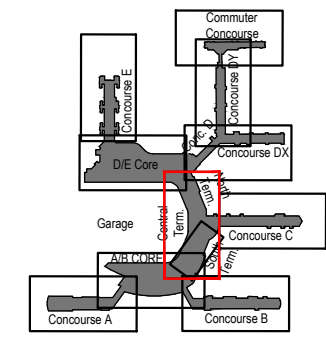

Key Plan: Airport

# Concourse C - Upper Level (Level 2)

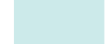
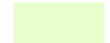
CONCESSIONS POWER SOURCE:	SUBSTATION AMPACITY/VOLTAGE:	EXISTING PEAK DEMAND (kW-Date):	125% OF PEAK DEMAND:	REMAINING LOAD AVAILABLE (kVA):	50% AVAILABLE FOR CONCESSIONS (kVA):
 SUBSTATION NT-CT	4000A / 480V	579kW - 07/20	724kW	2520kVA	1260kVA
 SUBSTATION C-1	4000A / 480V	1941kW* - DATE N/A	2426kW	620kVA*	310kVA

\* PEAK DEMAND FROM SWITCHGEAR #1 BREAKER N14 WHICH INCLUDES SUBSTATION C-1, R/W PUMP STATION AND AIRFIELD LIGHTING SUBSTATION. THE AVAILABLE CAPACITY LISTED IS A MINIMUM.

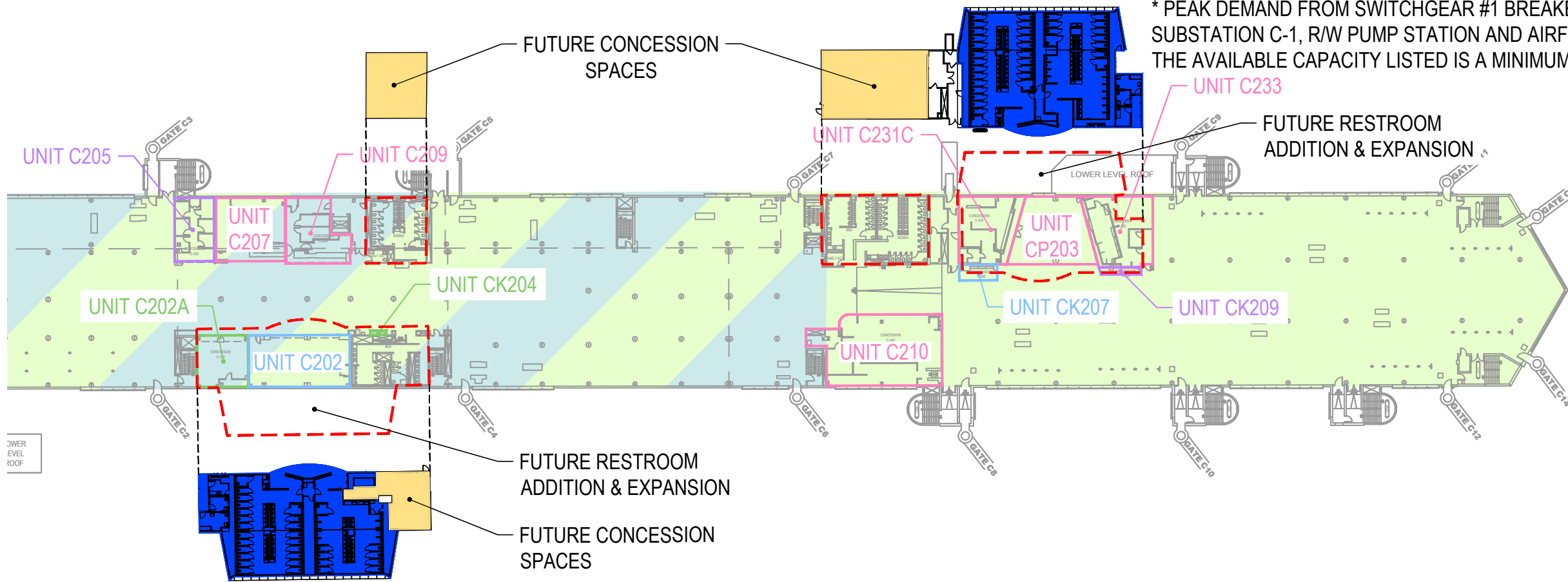

### Concession Category

-  Food Service
-  Convenience Retail
-  Specialty Retail
-  Vending
-  Services
-  Support Space
-  MAA Controlled



SCALE: 1/64" = 1'-0"

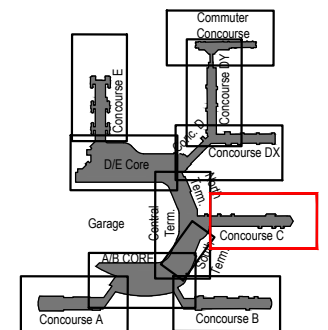

Key Plan: Airport



# Concourse D, DX - Upper Level (Level 2)

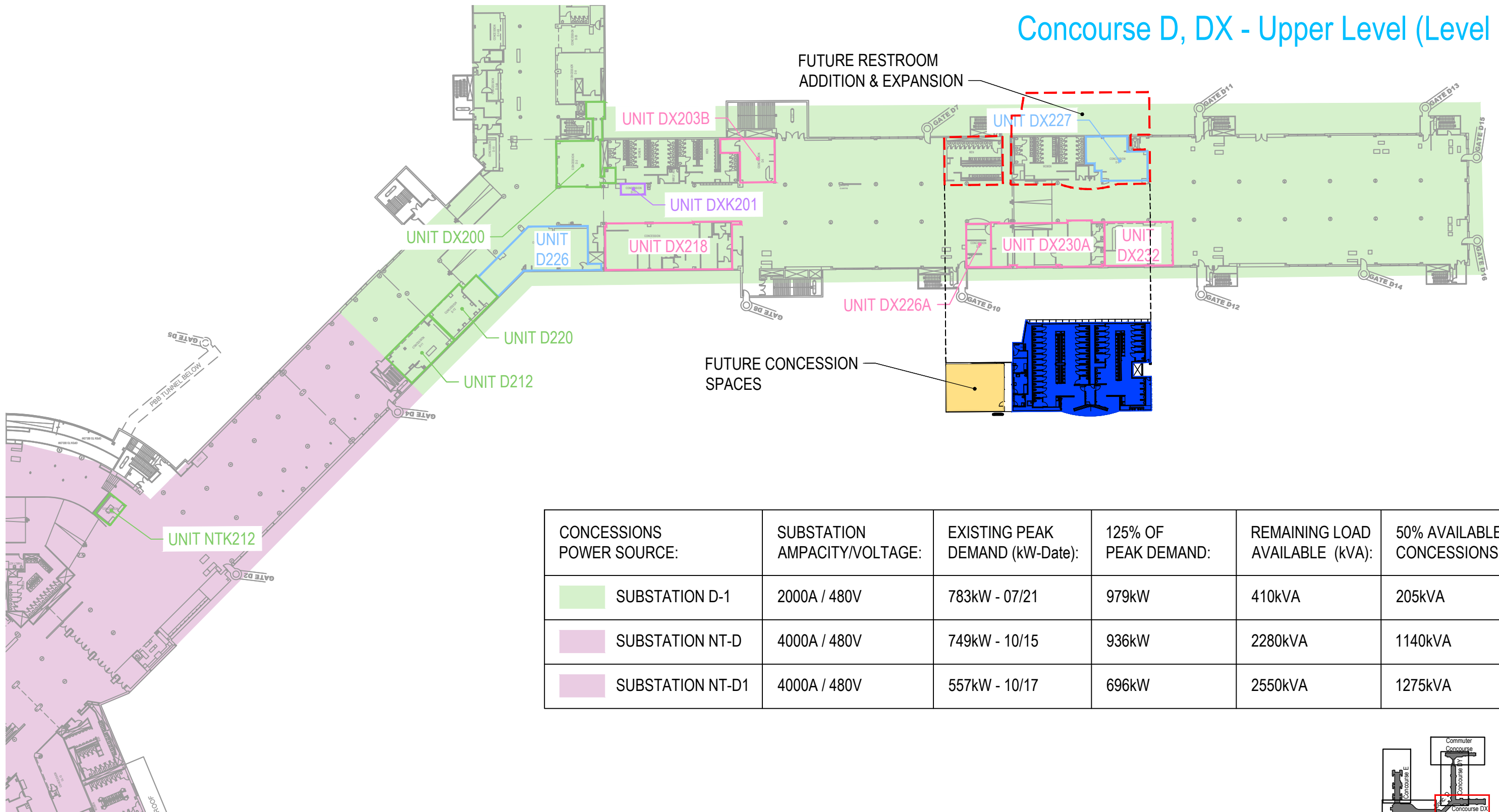

CONCESSIONS POWER SOURCE:	SUBSTATION AMPACITY/VOLTAGE:	EXISTING PEAK DEMAND (kW-Date):	125% OF PEAK DEMAND:	REMAINING LOAD AVAILABLE (kVA):	50% AVAILABLE FOR CONCESSIONS (kVA):
<span style="color: green;">■</span> SUBSTATION D-1	2000A / 480V	783kW - 07/21	979kW	410kVA	205kVA
<span style="color: purple;">■</span> SUBSTATION NT-D	4000A / 480V	749kW - 10/15	936kW	2280kVA	1140kVA
<span style="color: pink;">■</span> SUBSTATION NT-D1	4000A / 480V	557kW - 10/17	696kW	2550kVA	1275kVA

### Concession Category

- Food Service
- Convenience Retail
- Specialty Retail
- Vending
- Services
- Support Space
- MAA Controlled



SCALE: 1/64" = 1'-0"

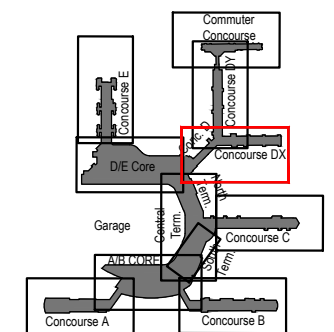

Key Plan: Airport



# Concourse DY - Upper Level (Level 2)

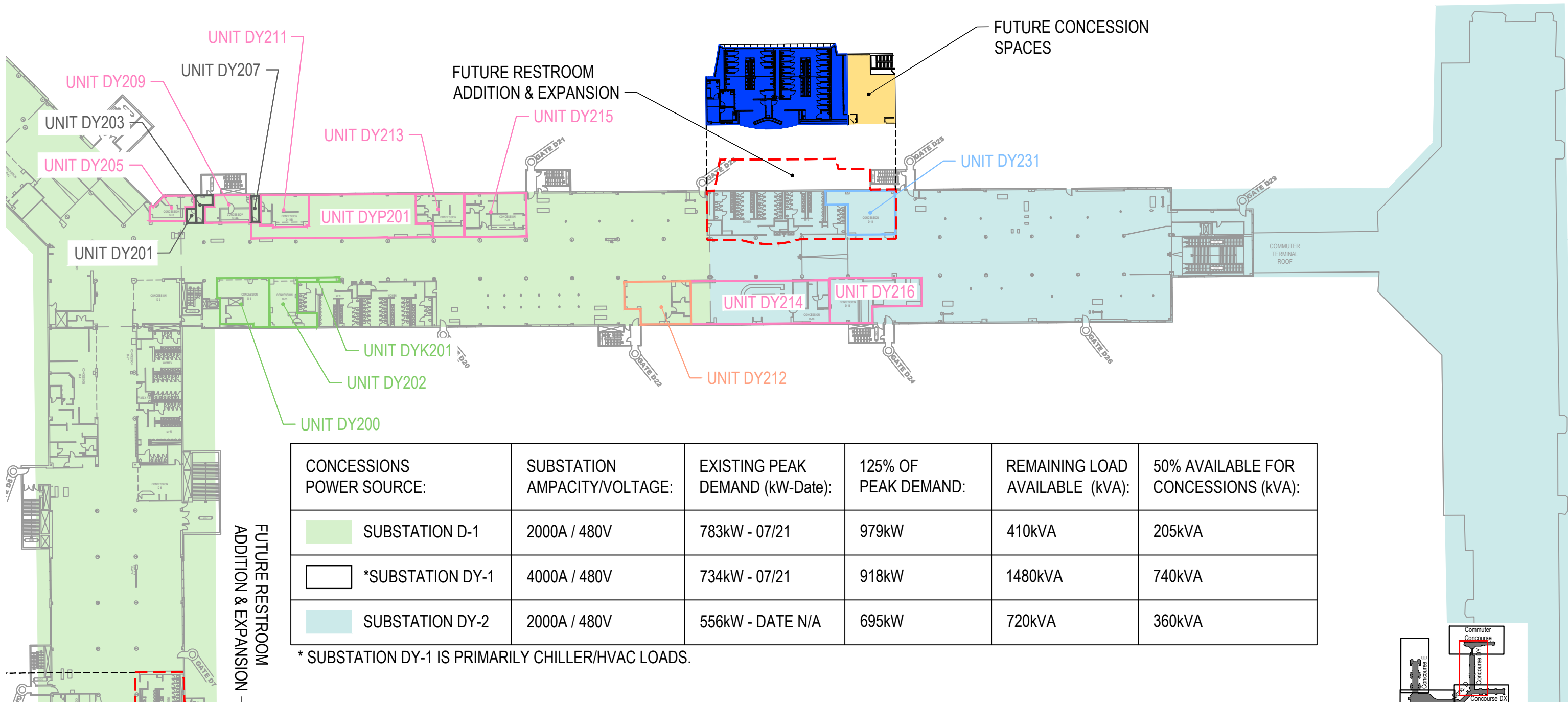

CONCESSIONS POWER SOURCE:	SUBSTATION AMPACITY/VOLTAGE:	EXISTING PEAK DEMAND (kW-Date):	125% OF PEAK DEMAND:	REMAINING LOAD AVAILABLE (kVA):	50% AVAILABLE FOR CONCESSIONS (kVA):
SUBSTATION D-1	2000A / 480V	783kW - 07/21	979kW	410kVA	205kVA
*SUBSTATION DY-1	4000A / 480V	734kW - 07/21	918kW	1480kVA	740kVA
SUBSTATION DY-2	2000A / 480V	556kW - DATE N/A	695kW	720kVA	360kVA

\* SUBSTATION DY-1 IS PRIMARILY CHILLER/HVAC LOADS.

FUTURE RESTROOM ADDITION & EXPANSION

**Concession Category**

- Food Service
- Convenience Retail
- Specialty Retail
- Vending
- Services
- Support Space
- MAA Controlled



SCALE: 1/64" = 1'-0"

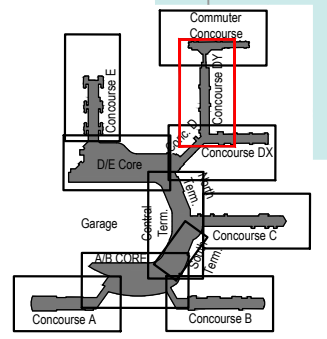

Key Plan: Airport

# D/E Core - Upper Level (Level 2)

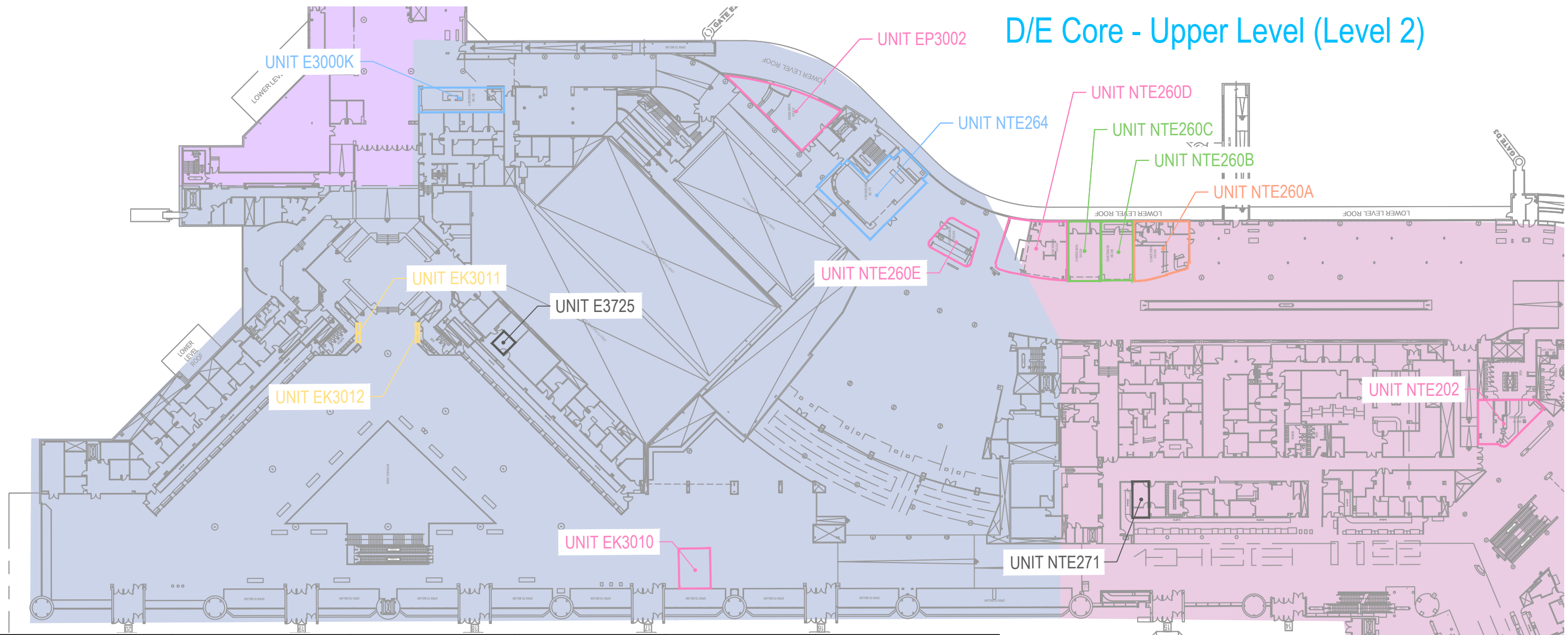

CONCESSIONS POWER SOURCE:	SUBSTATION AMPACITY/VOLTAGE:	EXISTING PEAK DEMAND (kW-Date):	125% OF PEAK DEMAND:	REMAINING LOAD AVAILABLE (kVA):	50% AVAILABLE FOR CONCESSIONS (kVA):
SUBSTATION NT-D	4000A / 480V	749kW - 10/15	936kW	2280kVA	1140kVA
SUBSTATION NT-D1	4000A / 480V	557kW - 10/17	696kW	2550kVA	1275kVA
SUBSTATION E-1	4000A / 480V	1186kW - DATE N/A	1483kW	1670kVA	835kVA

### Concession Category

- Food Service
- Convenience Retail
- Specialty Retail
- Vending
- Services
- Support Space
- MAA Controlled



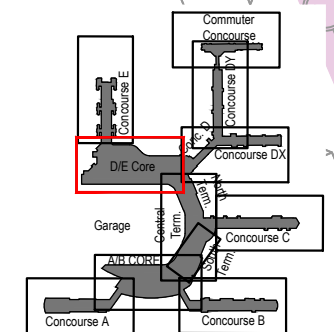

SCALE: 1/64" = 1'-0"

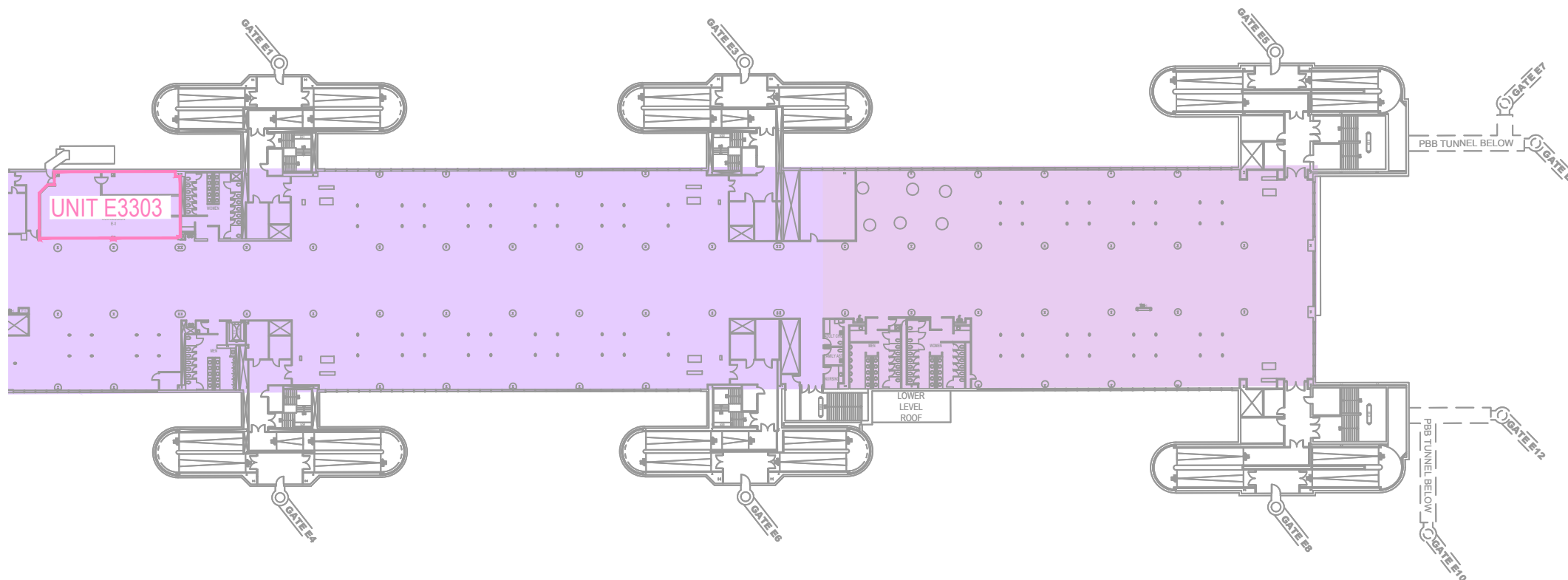

Key Plan: Airport

# Concourse E - Upper Level (Level 2)



CONCESSIONS POWER SOURCE:	SUBSTATION AMPACITY/VOLTAGE:	EXISTING PEAK DEMAND (kW-Date):	125% OF PEAK DEMAND:	REMAINING LOAD AVAILABLE (kVA):	50% AVAILABLE FOR CONCESSIONS (kVA):
 SUBSTATION E-2	4000A / 480V	348kW - 08/19*	435kW*	2840kVA*	1420kVA
 SUBSTATION E-3	4000A / 480V	348kW - 08/19*	435kW*	2840kVA*	1420kVA

\* PEAK DEMAND FOR SWITCHGEAR #2 BREAKER S22 WHICH INCLUDES BOTH SUBSTATION E-2 AND E-3.

### Concession Category

-  Food Service
-  Convenience Retail
-  Specialty Retail
-  Vending
-  Services
-  Support Space
-  MAA Controlled



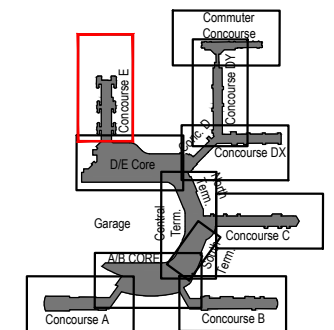

SCALE: 1/64" = 1'-0"

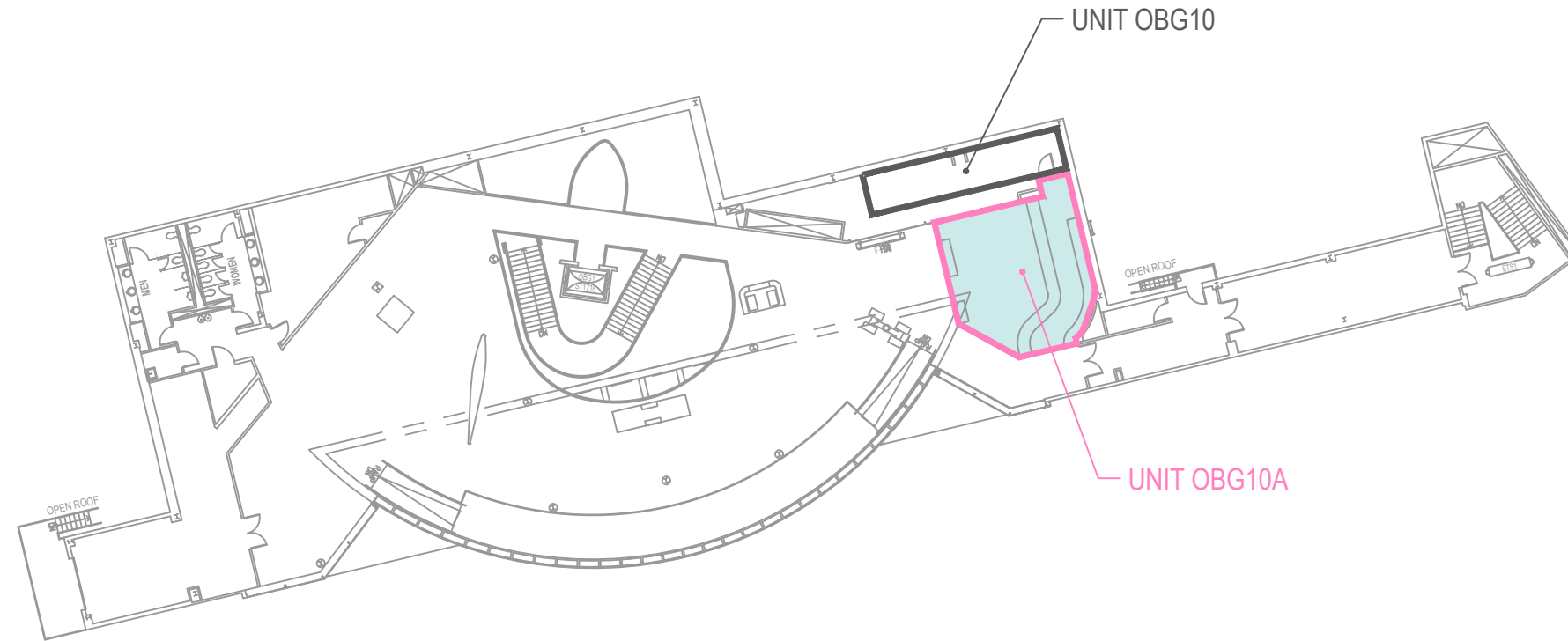

Key Plan: Airport

# Terminal Observation Gallery - Upper Level Mezzanine



CONCESSIONS POWER SOURCE:	SUBSTATION AMPACITY/VOLTAGE:	EXISTING PEAK DEMAND (kW-Date):	125% OF PEAK DEMAND:	REMAINING LOAD AVAILABLE (kVA):	50% AVAILABLE FOR CONCESSIONS (kVA):
 SUBSTATION NT-CT	4000A / 480V	579kW - 07/20	724kW	2520kVA	1260kVA

### Concession Category

-  Food Service
-  Convenience Retail
-  Specialty Retail
-  Vending
-  Services
-  Support Space
-  MAA Controlled



SCALE: 1/32" = 1'-0"

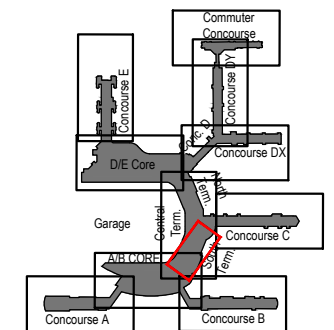

Key Plan: Airport



# Concourse A - Ground Level (Level 1a)

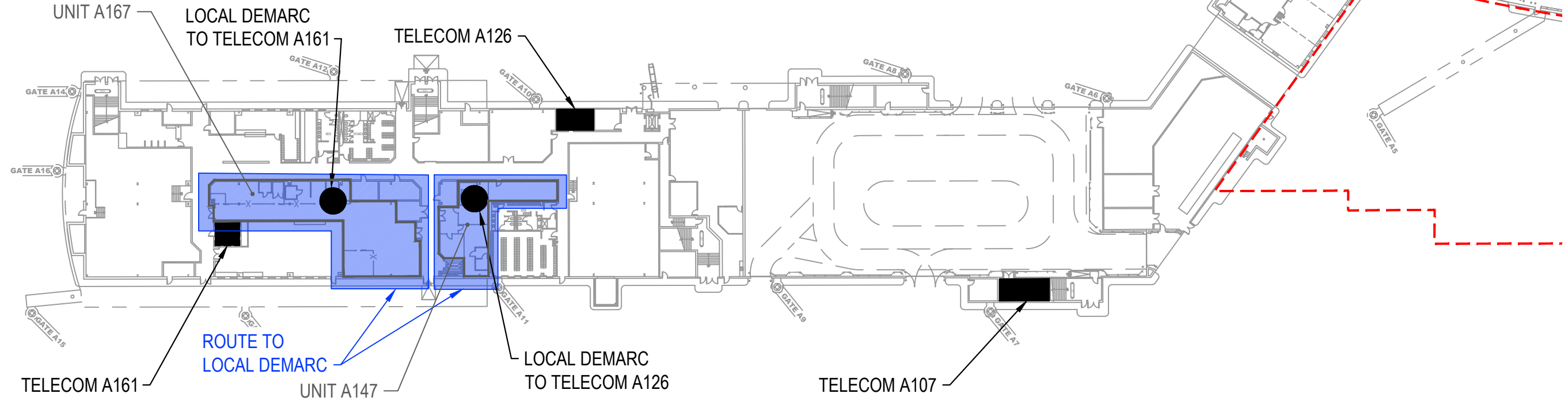

**ICT LEGEND**

- ICT COMM. RM. THIS LEVEL
- ICT COMM. RM. LEVEL AS NOTED
- LOCAL TENANT DEMARC

**GENERAL NOTES:**

1. APPROXIMATE LOCATIONS OF COMMUNICATION ROOMS OR DEMARCATION POINTS USED BY CONCESSIONS ARE SHOWN FOR REFERENCE PURPOSES. TENANT TO ROUTE CABLES TO NEAREST NOTED LOCATION AND AS COORDINATED WITH MAA DEPARTMENT OF AIRPORT TECHNOLOGY (DAT).
2. SEE CAPACITY NARRATIVE FOR TENANT'S RESPONSIBILITY FOR SYSTEM CABLING OF ICT SYSTEMS.
3. SEE CAPACITY NARRATIVE REGARDING AVAILABILITY OF OTHER ICT AND SECURITY SYSTEMS.

**Concession Category**

<span style="display: inline-block; width: 15px; height: 15px; border: 1px solid pink; margin-right: 5px;"></span> Food Service	<span style="display: inline-block; width: 15px; height: 15px; border: 1px solid orange; margin-right: 5px;"></span> Services
<span style="display: inline-block; width: 15px; height: 15px; border: 1px solid blue; margin-right: 5px;"></span> Convenience Retail	<span style="display: inline-block; width: 15px; height: 15px; border: 1px solid grey; margin-right: 5px;"></span> Support Space
<span style="display: inline-block; width: 15px; height: 15px; border: 1px solid green; margin-right: 5px;"></span> Specialty Retail	<span style="display: inline-block; width: 15px; height: 15px; border: 1px solid purple; margin-right: 5px;"></span> MAA Controlled
<span style="display: inline-block; width: 15px; height: 15px; border: 1px solid yellow; margin-right: 5px;"></span> Vending	

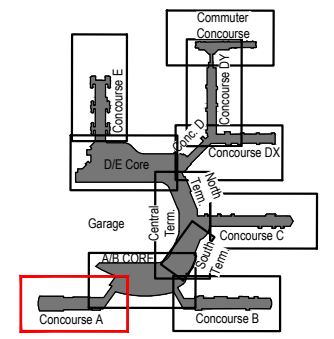

Key Plan: Airport



# A/B Core - Ground Level (Level 1a)

## GENERAL NOTES:

1. APPROXIMATE LOCATIONS OF COMMUNICATION ROOMS OR DEMARCATION POINTS USED BY CONCESSIONS ARE SHOWN FOR REFERENCE PURPOSES. TENANT TO ROUTE CABLES TO NEAREST NOTED LOCATION AND AS COORDINATED WITH MAA DEPARTMENT OF AIRPORT TECHNOLOGY (DAT).
2. SEE CAPACITY NARRATIVE FOR TENANT'S RESPONSIBILITY FOR SYSTEM CABLING OF ICT SYSTEMS.
3. SEE CAPACITY NARRATIVE REGARDING AVAILABILITY OF OTHER ICT AND SECURITY SYSTEMS.

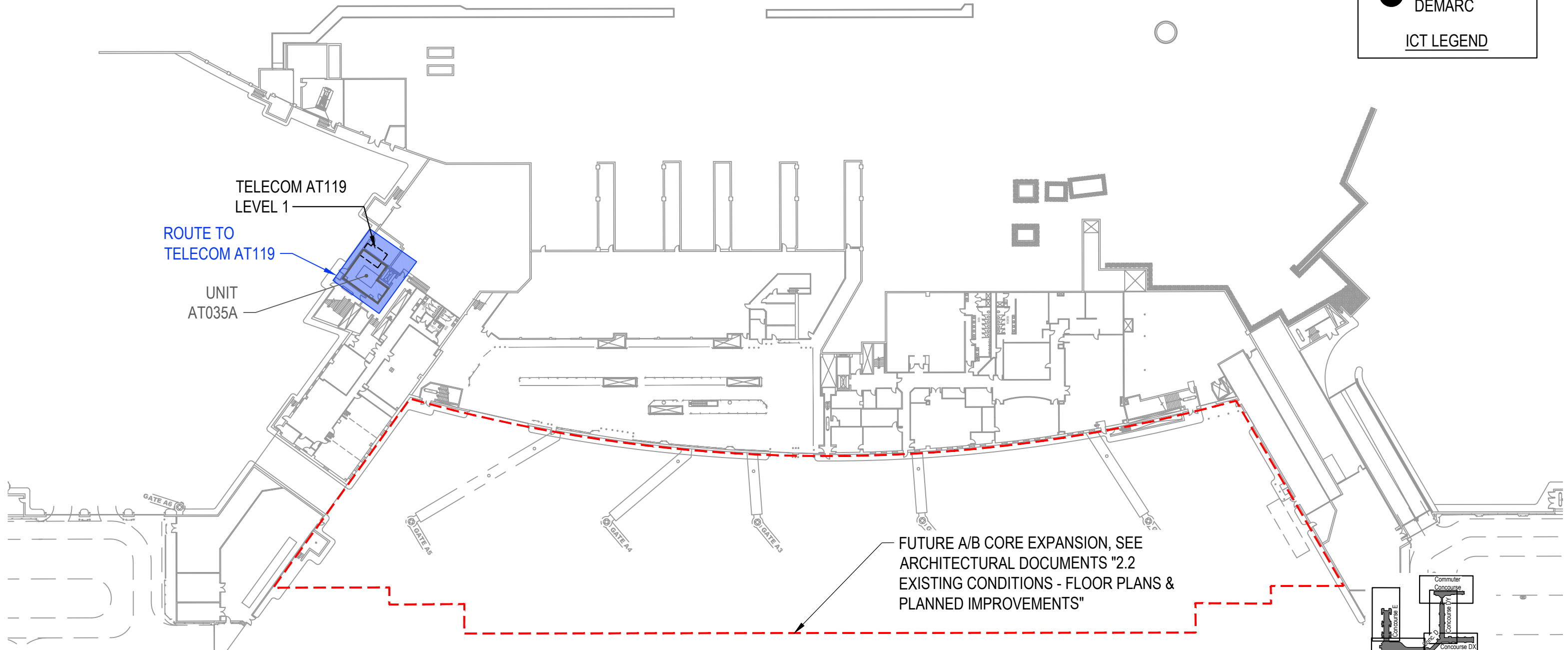
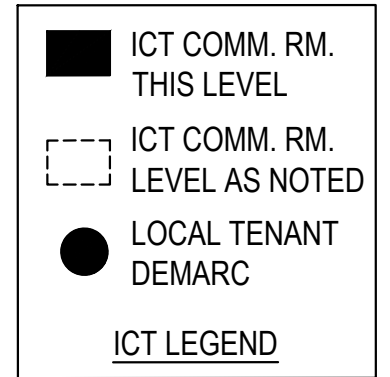

### Concession Category



FUTURE A/B CORE EXPANSION, SEE ARCHITECTURAL DOCUMENTS "2.2 EXISTING CONDITIONS - FLOOR PLANS & PLANNED IMPROVEMENTS"

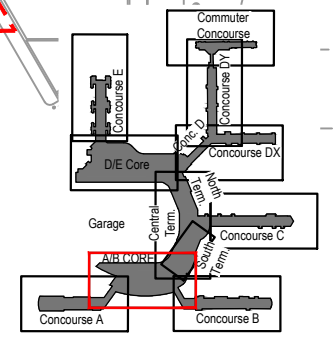

SCALE: 1/64" = 1'-0"

# Concourse B - Ground Level (Level 1a)

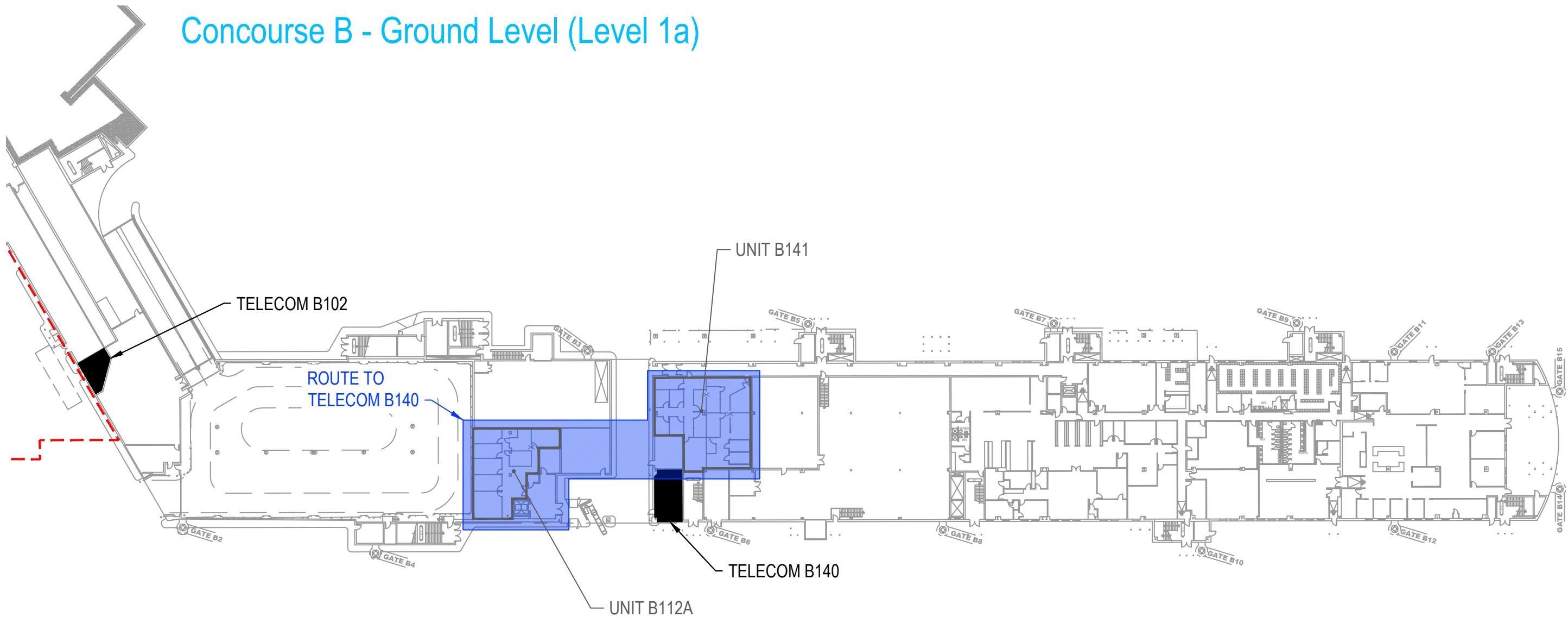

**ICT LEGEND**

- ICT COMM. RM. THIS LEVEL
- ICT COMM. RM. LEVEL AS NOTED
- LOCAL TENANT DEMARC

**GENERAL NOTES:**

1. APPROXIMATE LOCATIONS OF COMMUNICATION ROOMS OR DEMARCATION POINTS USED BY CONCESSIONS ARE SHOWN FOR REFERENCE PURPOSES. TENANT TO ROUTE CABLES TO NEAREST NOTED LOCATION AND AS COORDINATED WITH MAA DEPARTMENT OF AIRPORT TECHNOLOGY (DAT).
2. SEE CAPACITY NARRATIVE FOR TENANT'S RESPONSIBILITY FOR SYSTEM CABLING OF ICT SYSTEMS.
3. SEE CAPACITY NARRATIVE REGARDING AVAILABILITY OF OTHER ICT AND SECURITY SYSTEMS.

**Concession Category**

<ul style="list-style-type: none"> <li><span style="display: inline-block; width: 15px; height: 15px; border: 1px solid pink; margin-right: 5px;"></span> Food Service</li> <li><span style="display: inline-block; width: 15px; height: 15px; border: 1px solid blue; margin-right: 5px;"></span> Convenience Retail</li> <li><span style="display: inline-block; width: 15px; height: 15px; border: 1px solid green; margin-right: 5px;"></span> Specialty Retail</li> <li><span style="display: inline-block; width: 15px; height: 15px; border: 1px solid orange; margin-right: 5px;"></span> Vending</li> </ul>	<ul style="list-style-type: none"> <li><span style="display: inline-block; width: 15px; height: 15px; border: 1px solid orange; margin-right: 5px;"></span> Services</li> <li><span style="display: inline-block; width: 15px; height: 15px; border: 1px solid grey; margin-right: 5px;"></span> Support Space</li> <li><span style="display: inline-block; width: 15px; height: 15px; border: 1px solid purple; margin-right: 5px;"></span> MAA Controlled</li> </ul>
--	--



SCALE: 1/64" = 1'-0"

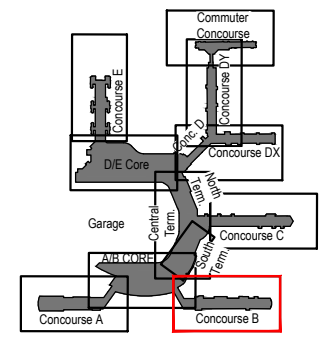

Key Plan: Airport

# A/B Core - Lower Level (Level 1)

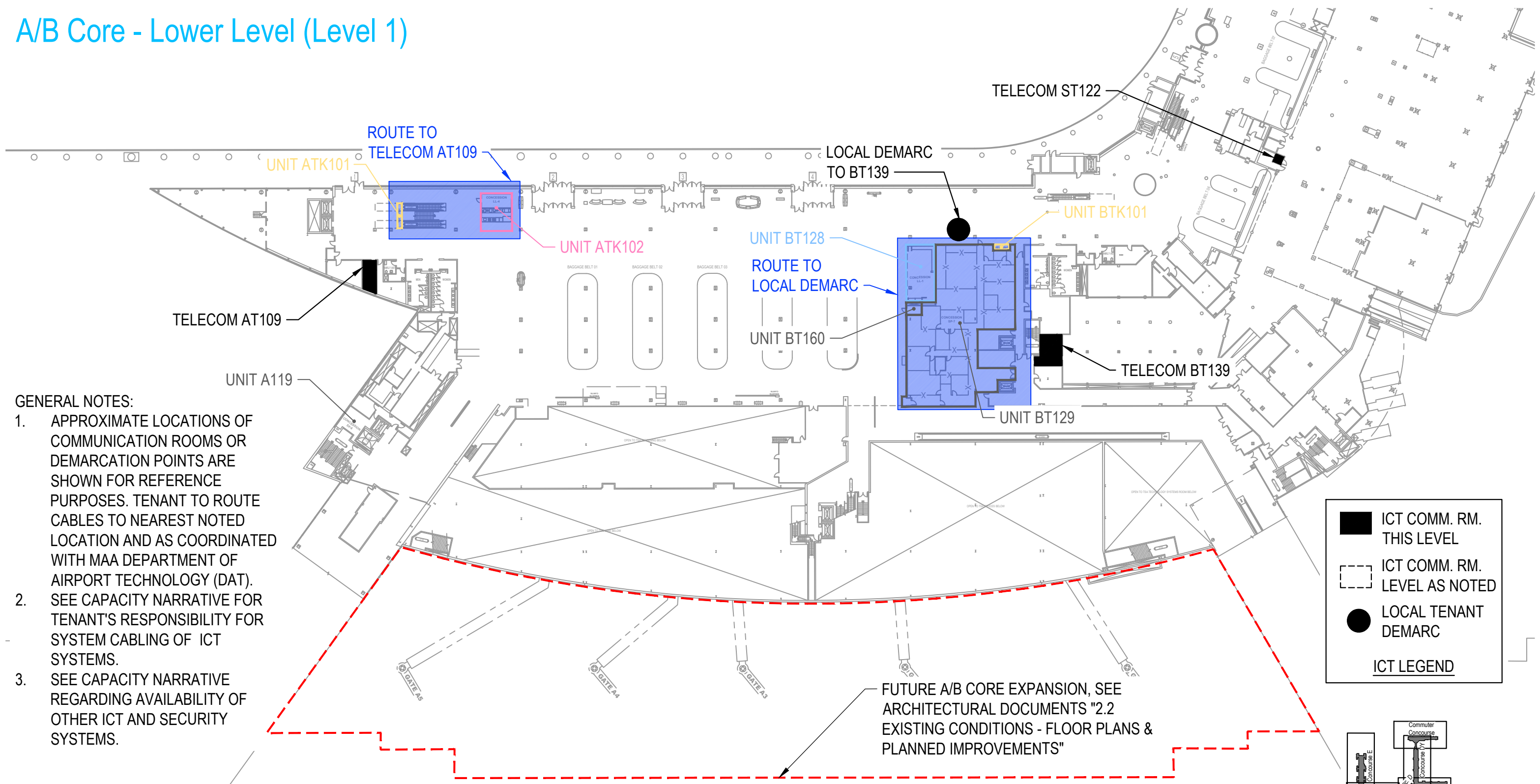

**GENERAL NOTES:**

1. APPROXIMATE LOCATIONS OF COMMUNICATION ROOMS OR DEMARCATION POINTS ARE SHOWN FOR REFERENCE PURPOSES. TENANT TO ROUTE CABLES TO NEAREST NOTED LOCATION AND AS COORDINATED WITH MAA DEPARTMENT OF AIRPORT TECHNOLOGY (DAT).
2. SEE CAPACITY NARRATIVE FOR TENANT'S RESPONSIBILITY FOR SYSTEM CABLING OF ICT SYSTEMS.
3. SEE CAPACITY NARRATIVE REGARDING AVAILABILITY OF OTHER ICT AND SECURITY SYSTEMS.

**ICT LEGEND**

- ICT COMM. RM. THIS LEVEL
- ICT COMM. RM. LEVEL AS NOTED
- LOCAL TENANT DEMARC

**Concession Category**

<span style="display: inline-block; width: 15px; height: 15px; border: 1px solid pink;"></span>	Food Service	<span style="display: inline-block; width: 15px; height: 15px; border: 1px solid orange;"></span>	Services
<span style="display: inline-block; width: 15px; height: 15px; border: 1px solid blue;"></span>	Convenience Retail	<span style="display: inline-block; width: 15px; height: 15px; border: 1px solid grey;"></span>	Support Space
<span style="display: inline-block; width: 15px; height: 15px; border: 1px solid green;"></span>	Specialty Retail	<span style="display: inline-block; width: 15px; height: 15px; border: 1px solid purple;"></span>	MAA Controlled
<span style="display: inline-block; width: 15px; height: 15px; border: 1px solid yellow;"></span>	Vending		

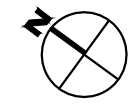
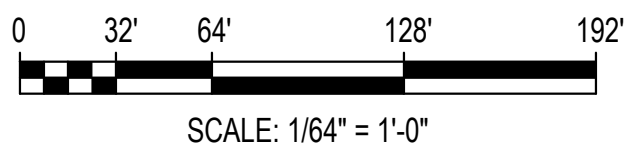
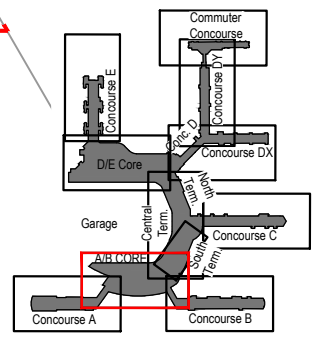



# Terminal South, Center, North - Lower Level (Level 1)

## GENERAL NOTES:

1. APPROXIMATE LOCATIONS OF COMMUNICATION ROOMS OR DEMARCATION POINTS ARE SHOWN FOR REFERENCE PURPOSES. TENANT TO ROUTE CABLES TO NEAREST NOTED LOCATION AND AS COORDINATED WITH MAA DEPARTMENT OF AIRPORT TECHNOLOGY (DAT).
2. SEE CAPACITY NARRATIVE FOR TENANT'S RESPONSIBILITY FOR SYSTEM CABLING OF ICT SYSTEMS.
3. SEE CAPACITY NARRATIVE REGARDING AVAILABILITY OF OTHER ICT AND SECURITY SYSTEMS.

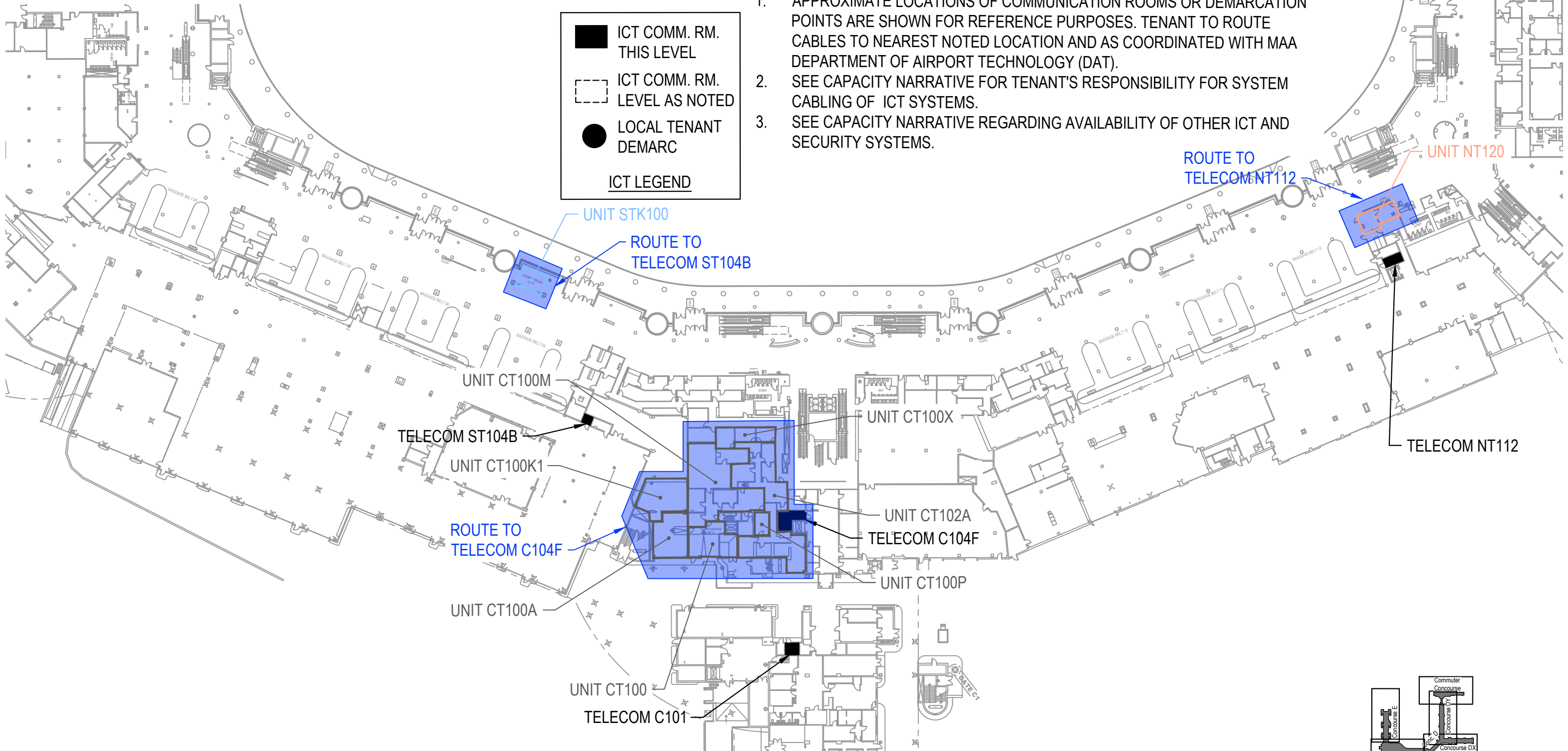
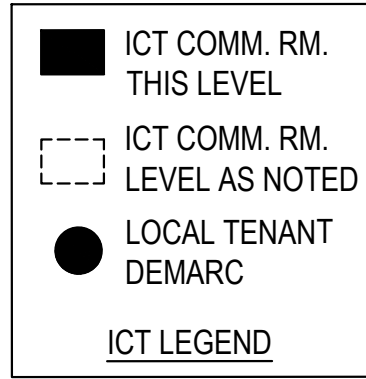

### Concession Category



SCALE: 1/64" = 1'-0"

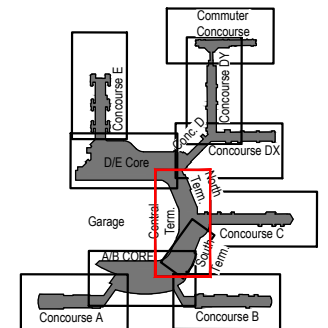

Key Plan: Airport

# Concourse C - Lower Level (Level 1)

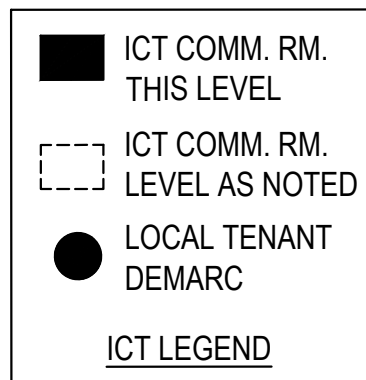
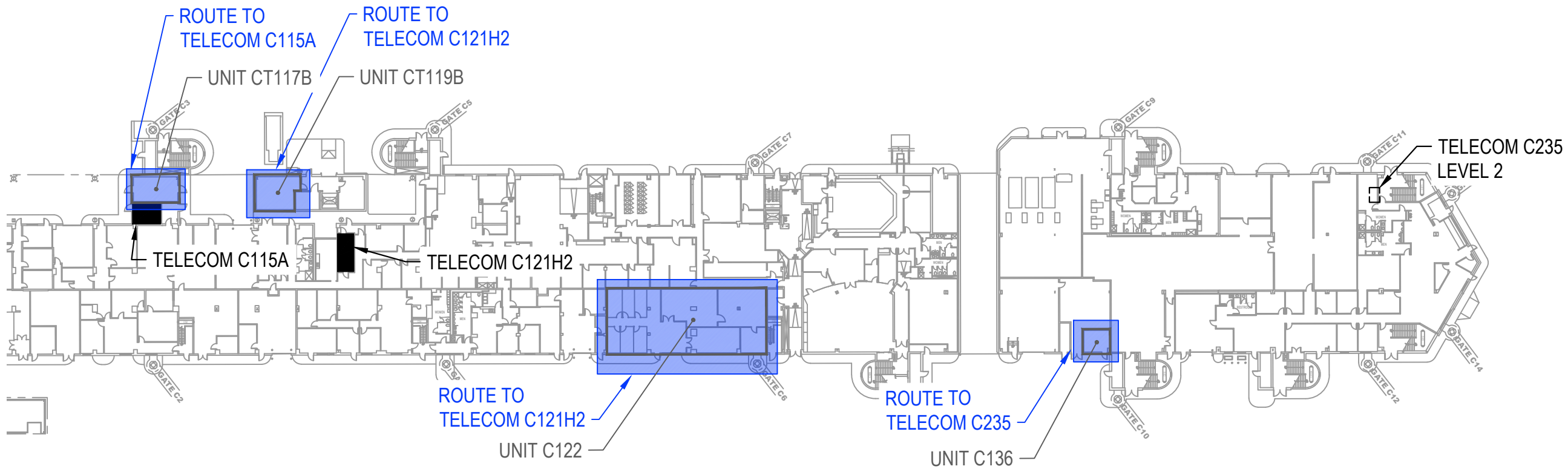

### GENERAL NOTES:

1. APPROXIMATE LOCATIONS OF COMMUNICATION ROOMS OR DEMARCATION POINTS ARE SHOWN FOR REFERENCE PURPOSES. TENANT TO ROUTE CABLES TO NEAREST NOTED LOCATION AND AS COORDINATED WITH MAA DEPARTMENT OF AIRPORT TECHNOLOGY (DAT).
2. SEE CAPACITY NARRATIVE FOR TENANT'S RESPONSIBILITY FOR SYSTEM CABLING OF ICT SYSTEMS.
3. SEE CAPACITY NARRATIVE REGARDING AVAILABILITY OF OTHER ICT AND SECURITY SYSTEMS.

### Concession Category



SCALE: 1/64" = 1'-0"

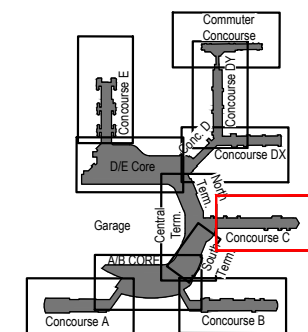

Key Plan: Airport

# Concourse D, DX - Lower Level (Level 1)

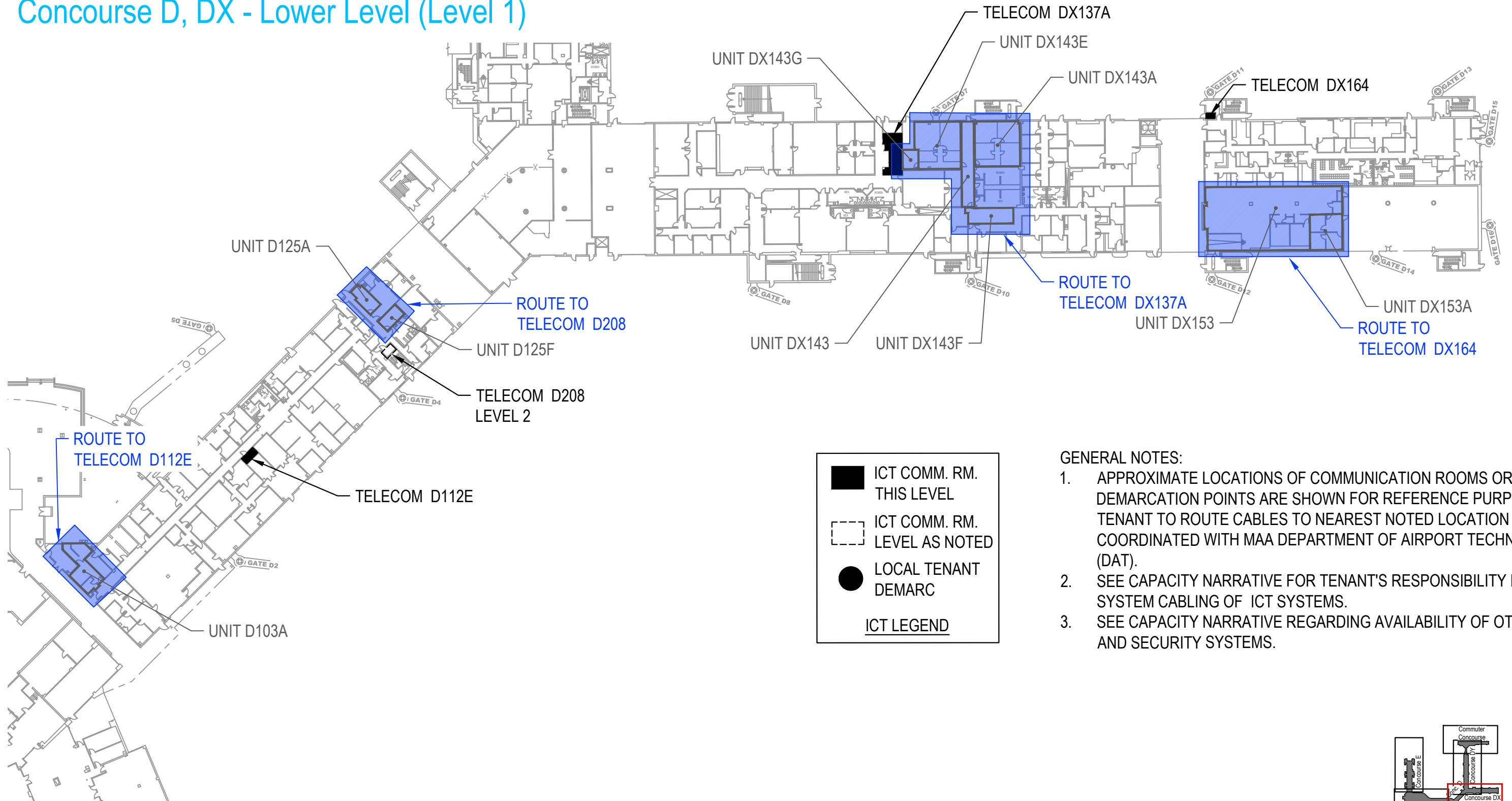

- GENERAL NOTES:**
1. APPROXIMATE LOCATIONS OF COMMUNICATION ROOMS OR DEMARCATION POINTS ARE SHOWN FOR REFERENCE PURPOSES. TENANT TO ROUTE CABLES TO NEAREST NOTED LOCATION AND AS COORDINATED WITH MAA DEPARTMENT OF AIRPORT TECHNOLOGY (DAT).
  2. SEE CAPACITY NARRATIVE FOR TENANT'S RESPONSIBILITY FOR SYSTEM CABLING OF ICT SYSTEMS.
  3. SEE CAPACITY NARRATIVE REGARDING AVAILABILITY OF OTHER ICT AND SECURITY SYSTEMS.

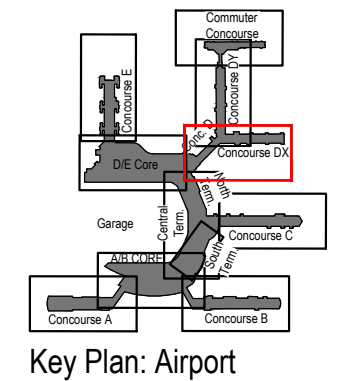
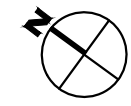
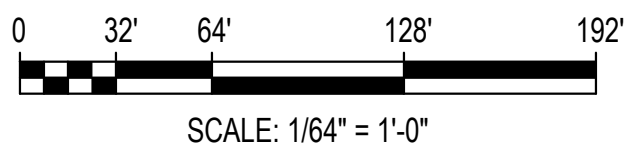



# Concourse DY - Lower Level (Level 1)

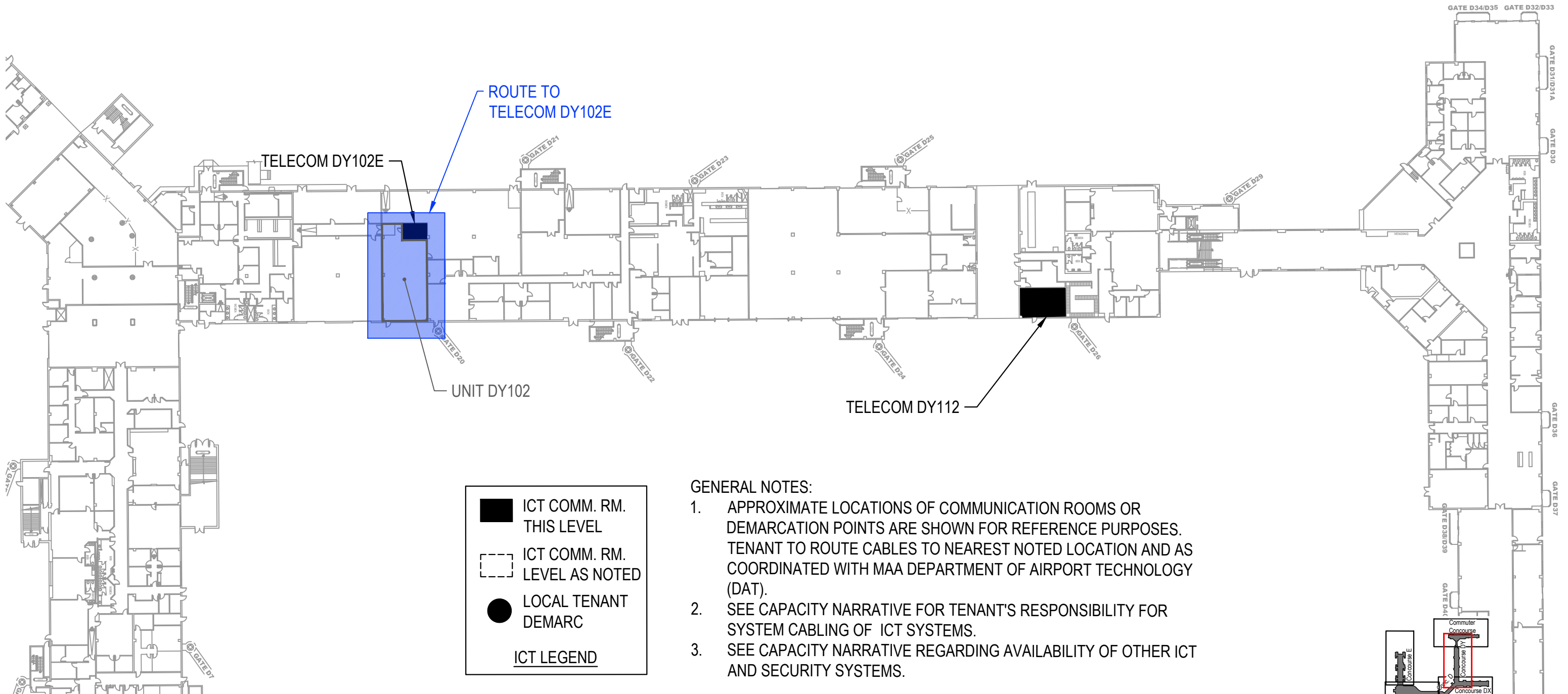

**GENERAL NOTES:**

1. APPROXIMATE LOCATIONS OF COMMUNICATION ROOMS OR DEMARCATION POINTS ARE SHOWN FOR REFERENCE PURPOSES. TENANT TO ROUTE CABLES TO NEAREST NOTED LOCATION AND AS COORDINATED WITH MAA DEPARTMENT OF AIRPORT TECHNOLOGY (DAT).
2. SEE CAPACITY NARRATIVE FOR TENANT'S RESPONSIBILITY FOR SYSTEM CABLING OF ICT SYSTEMS.
3. SEE CAPACITY NARRATIVE REGARDING AVAILABILITY OF OTHER ICT AND SECURITY SYSTEMS.

**Concession Category**

- |  |  |
|--|--|
| <span style="border: 1px solid pink; display: inline-block; width: 15px; height: 10px;"></span> Food Service       | <span style="border: 1px solid orange; display: inline-block; width: 15px; height: 10px;"></span> Services       |
| <span style="border: 1px solid blue; display: inline-block; width: 15px; height: 10px;"></span> Convenience Retail | <span style="border: 1px solid grey; display: inline-block; width: 15px; height: 10px;"></span> Support Space    |
| <span style="border: 1px solid green; display: inline-block; width: 15px; height: 10px;"></span> Specialty Retail  | <span style="border: 1px solid purple; display: inline-block; width: 15px; height: 10px;"></span> MAA Controlled |
| <span style="border: 1px solid yellow; display: inline-block; width: 15px; height: 10px;"></span> Vending          |  |

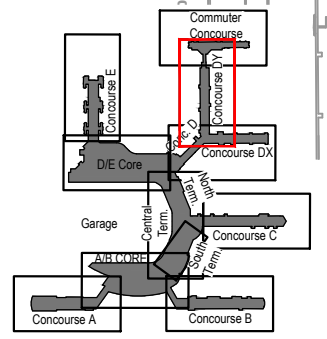

Key Plan: Airport



SCALE: 1/64" = 1'-0"

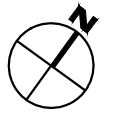



# Commuter Concourse D - Lower Level (Level 1)

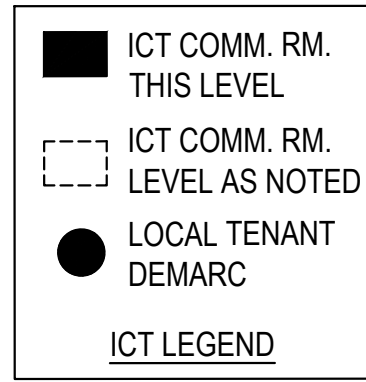

## GENERAL NOTES:

1. APPROXIMATE LOCATIONS OF COMMUNICATION ROOMS OR DEMARCATION POINTS ARE SHOWN FOR REFERENCE PURPOSES. TENANT TO ROUTE CABLES TO NEAREST NOTED LOCATION AND AS COORDINATED WITH MAA DEPARTMENT OF AIRPORT TECHNOLOGY (DAT).
2. SEE CAPACITY NARRATIVE FOR TENANT'S RESPONSIBILITY FOR SYSTEM CABLING OF ICT SYSTEMS.
3. SEE CAPACITY NARRATIVE REGARDING AVAILABILITY OF OTHER ICT AND SECURITY SYSTEMS.

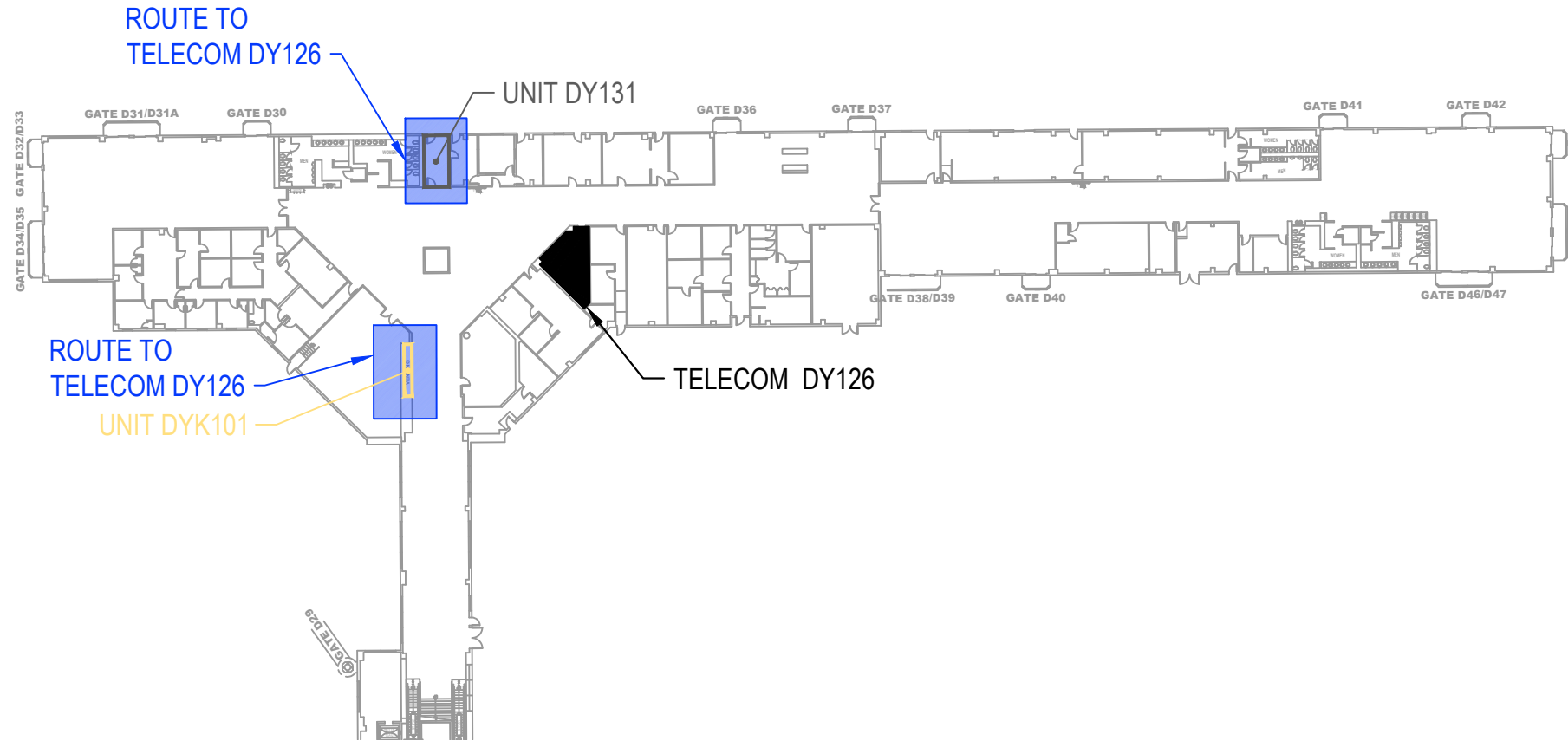

## Concession Category



SCALE: 1/64" = 1'-0"

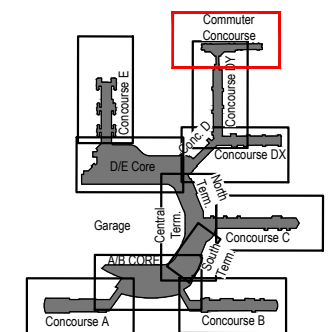

Key Plan: Airport

# D/E Core - Lower Level (Level 1)

**ICT LEGEND**

- ICT COMM. RM. THIS LEVEL
- ▭ ICT COMM. RM. LEVEL AS NOTED
- LOCAL TENANT DEMARC

**GENERAL NOTES:**

1. APPROXIMATE LOCATIONS OF COMMUNICATION ROOMS OR DEMARCATION POINTS ARE SHOWN FOR REFERENCE PURPOSES. TENANT TO ROUTE CABLES TO NEAREST NOTED LOCATION AND AS COORDINATED WITH MAA DEPARTMENT OF AIRPORT TECHNOLOGY (DAT).
2. SEE CAPACITY NARRATIVE FOR TENANT'S RESPONSIBILITY FOR SYSTEM CABLING OF ICT SYSTEMS.
3. SEE CAPACITY NARRATIVE REGARDING AVAILABILITY OF OTHER ICT AND SECURITY SYSTEMS.

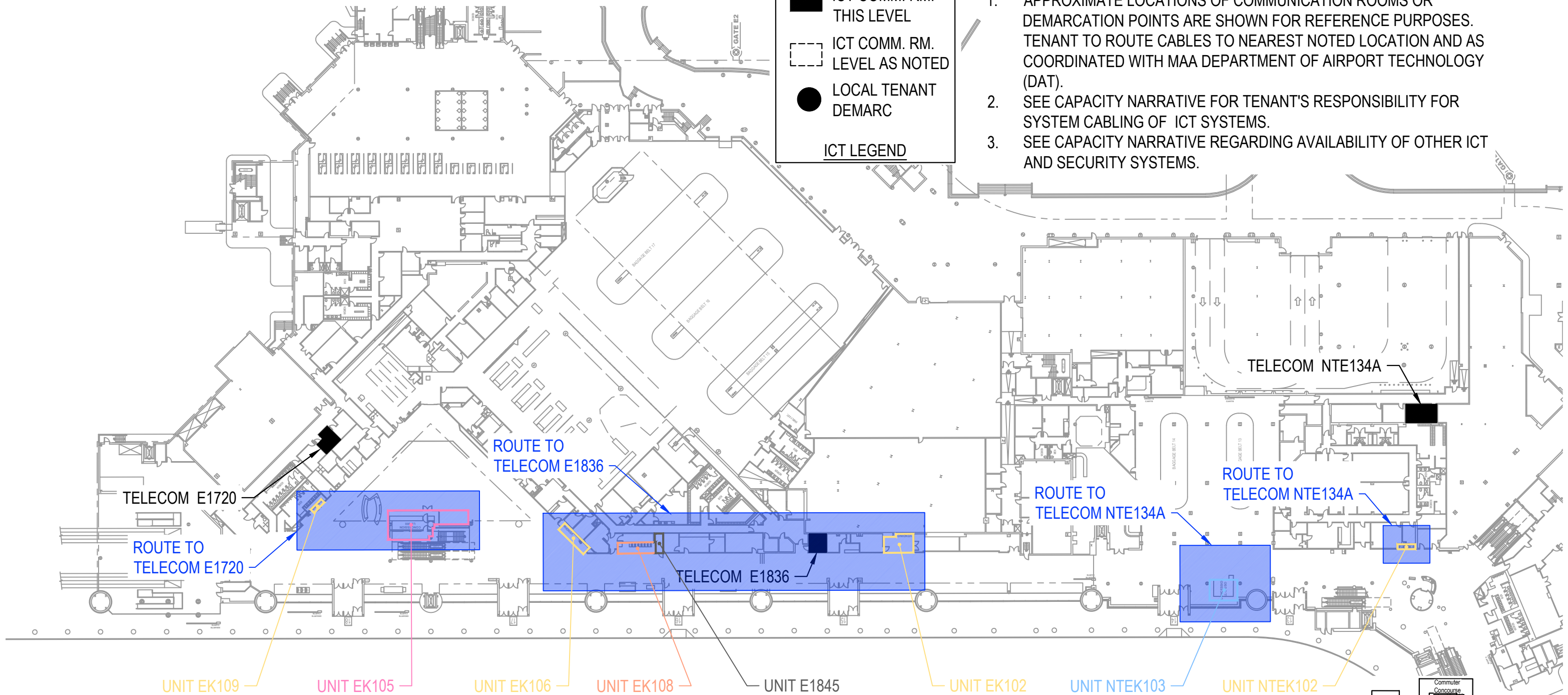

**Concession Category**

<span style="border: 1px solid pink; display: inline-block; width: 15px; height: 10px;"></span> Food Service	<span style="border: 1px solid orange; display: inline-block; width: 15px; height: 10px;"></span> Services
<span style="border: 1px solid blue; display: inline-block; width: 15px; height: 10px;"></span> Convenience Retail	<span style="border: 1px solid black; display: inline-block; width: 15px; height: 10px;"></span> Support Space
<span style="border: 1px solid green; display: inline-block; width: 15px; height: 10px;"></span> Specialty Retail	<span style="border: 1px solid purple; display: inline-block; width: 15px; height: 10px;"></span> MAA Controlled
<span style="border: 1px solid yellow; display: inline-block; width: 15px; height: 10px;"></span> Vending	

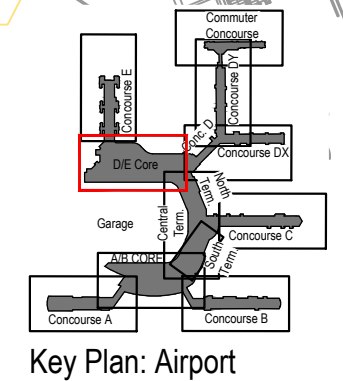

SCALE: 1/64" = 1'-0"



# Concourse E - Lower Level (Level 1)

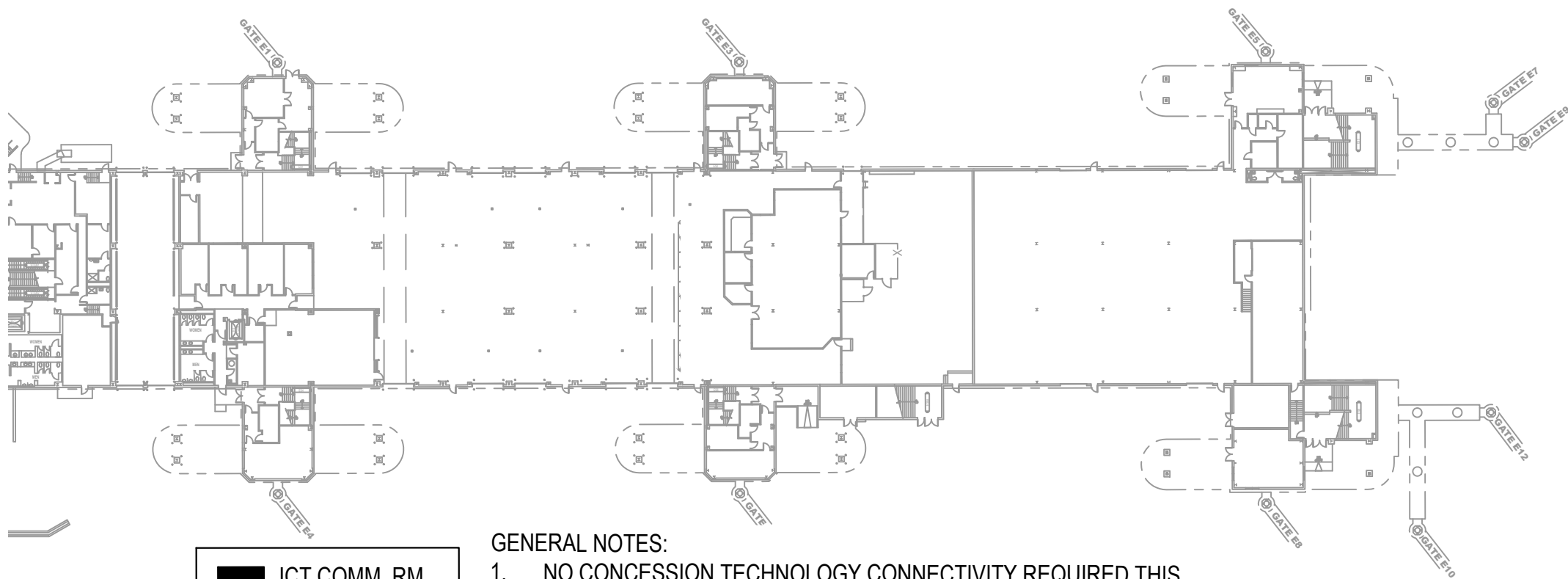

GENERAL NOTES:  
 1. NO CONCESSION TECHNOLOGY CONNECTIVITY REQUIRED THIS PAGE.

**ICT LEGEND**

- ICT COMM. RM. THIS LEVEL
- ICT COMM. RM. LEVEL AS NOTED
- LOCAL TENANT DEMARC

**Concession Category**

<span style="display: inline-block; width: 15px; height: 15px; border: 1px solid pink; margin-right: 5px;"></span> Food Service	<span style="display: inline-block; width: 15px; height: 15px; border: 1px solid orange; margin-right: 5px;"></span> Services
<span style="display: inline-block; width: 15px; height: 15px; border: 1px solid blue; margin-right: 5px;"></span> Convenience Retail	<span style="display: inline-block; width: 15px; height: 15px; border: 1px solid grey; margin-right: 5px;"></span> Support Space
<span style="display: inline-block; width: 15px; height: 15px; border: 1px solid green; margin-right: 5px;"></span> Specialty Retail	<span style="display: inline-block; width: 15px; height: 15px; border: 1px solid purple; margin-right: 5px;"></span> MAA Controlled
<span style="display: inline-block; width: 15px; height: 15px; border: 1px solid yellow; margin-right: 5px;"></span> Vending	

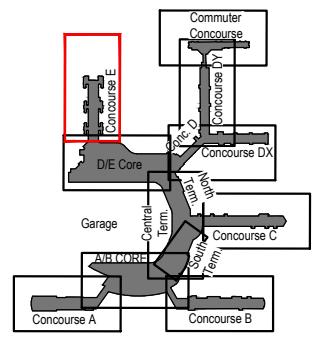
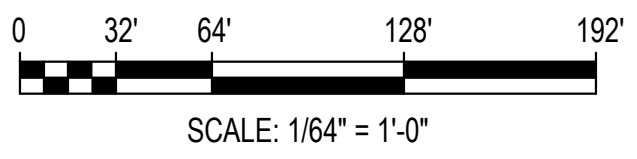

Key Plan: Airport

# Concourse A - Upper Level (Level 2)

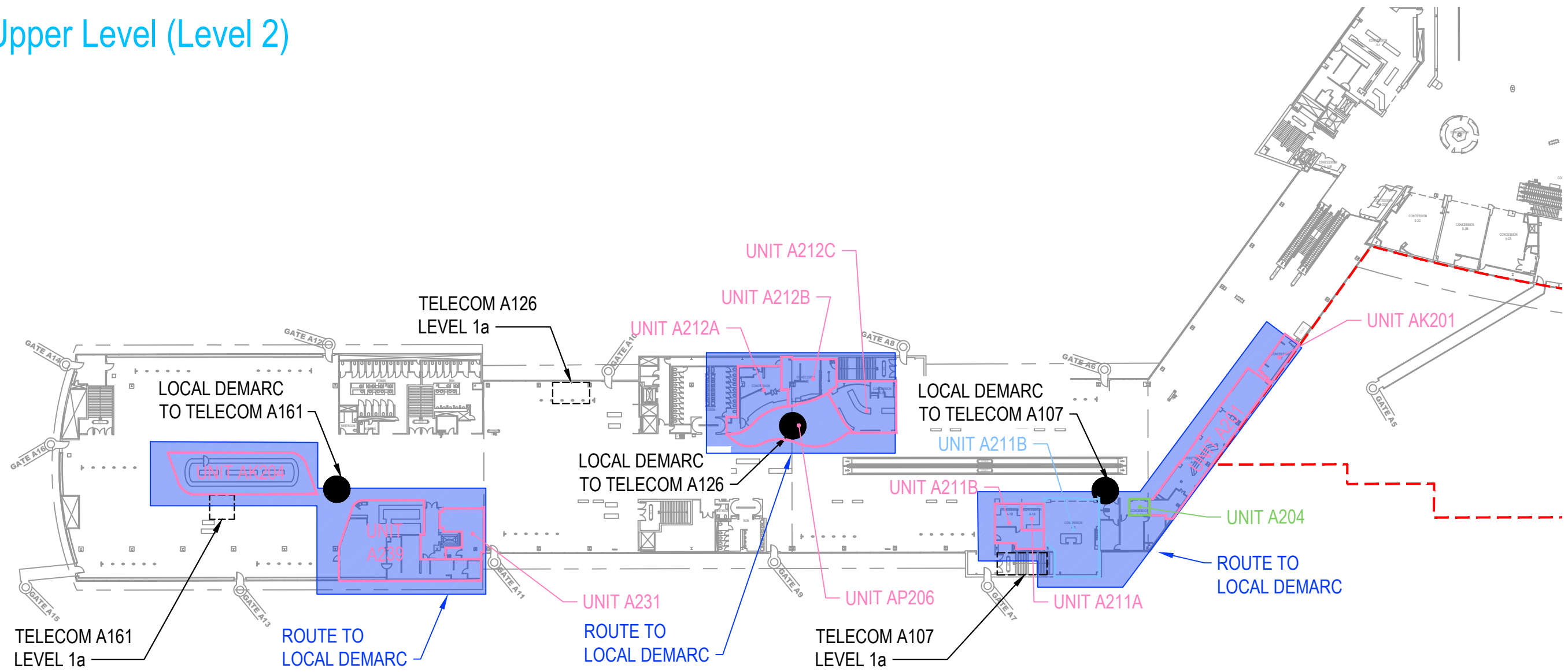

**ICT LEGEND**

- ICT COMM. RM. THIS LEVEL
- ICT COMM. RM. LEVEL AS NOTED
- LOCAL TENANT DEMARC

**GENERAL NOTES:**

1. APPROXIMATE LOCATIONS OF COMMUNICATION ROOMS OR DEMARCATION POINTS USED BY CONCESSIONS ARE SHOWN FOR REFERENCE PURPOSES. TENANT TO ROUTE CABLES TO NEAREST NOTED LOCATION AND AS COORDINATED WITH MAA DEPARTMENT OF AIRPORT TECHNOLOGY (DAT).
2. SEE CAPACITY NARRATIVE FOR TENANT'S RESPONSIBILITY FOR SYSTEM CABLING OF ICT SYSTEMS.
3. SEE CAPACITY NARRATIVE REGARDING AVAILABILITY OF OTHER ICT AND SECURITY SYSTEMS.

**Concession Category**

<span style="display: inline-block; width: 15px; height: 15px; border: 1px solid pink; margin-right: 5px;"></span> Food Service	<span style="display: inline-block; width: 15px; height: 15px; border: 1px solid orange; margin-right: 5px;"></span> Services
<span style="display: inline-block; width: 15px; height: 15px; border: 1px solid blue; margin-right: 5px;"></span> Convenience Retail	<span style="display: inline-block; width: 15px; height: 15px; border: 1px solid grey; margin-right: 5px;"></span> Support Space
<span style="display: inline-block; width: 15px; height: 15px; border: 1px solid green; margin-right: 5px;"></span> Specialty Retail	<span style="display: inline-block; width: 15px; height: 15px; border: 1px solid purple; margin-right: 5px;"></span> MAA Controlled
<span style="display: inline-block; width: 15px; height: 15px; border: 1px solid yellow; margin-right: 5px;"></span> Vending	

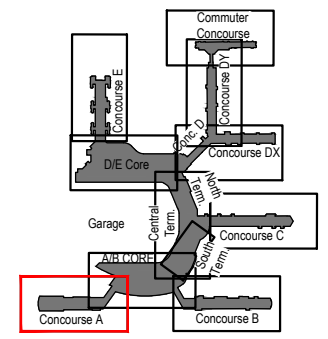

Key Plan: Airport



SCALE: 1/64" = 1'-0"





# A/B Core - Upper Level (Level 2)

## GENERAL NOTES:

1. APPROXIMATE LOCATIONS OF COMMUNICATION ROOMS OR DEMARCATION POINTS USED BY CONCESSIONS ARE SHOWN FOR REFERENCE PURPOSES. TENANT TO ROUTE CABLES TO NEAREST NOTED LOCATION AND AS COORDINATED WITH MAA DEPARTMENT OF AIRPORT TECHNOLOGY (DAT).
2. SEE CAPACITY NARRATIVE FOR TENANT'S RESPONSIBILITY FOR SYSTEM CABLING OF ICT SYSTEMS.
3. SEE CAPACITY NARRATIVE REGARDING AVAILABILITY OF OTHER ICT AND SECURITY SYSTEMS.

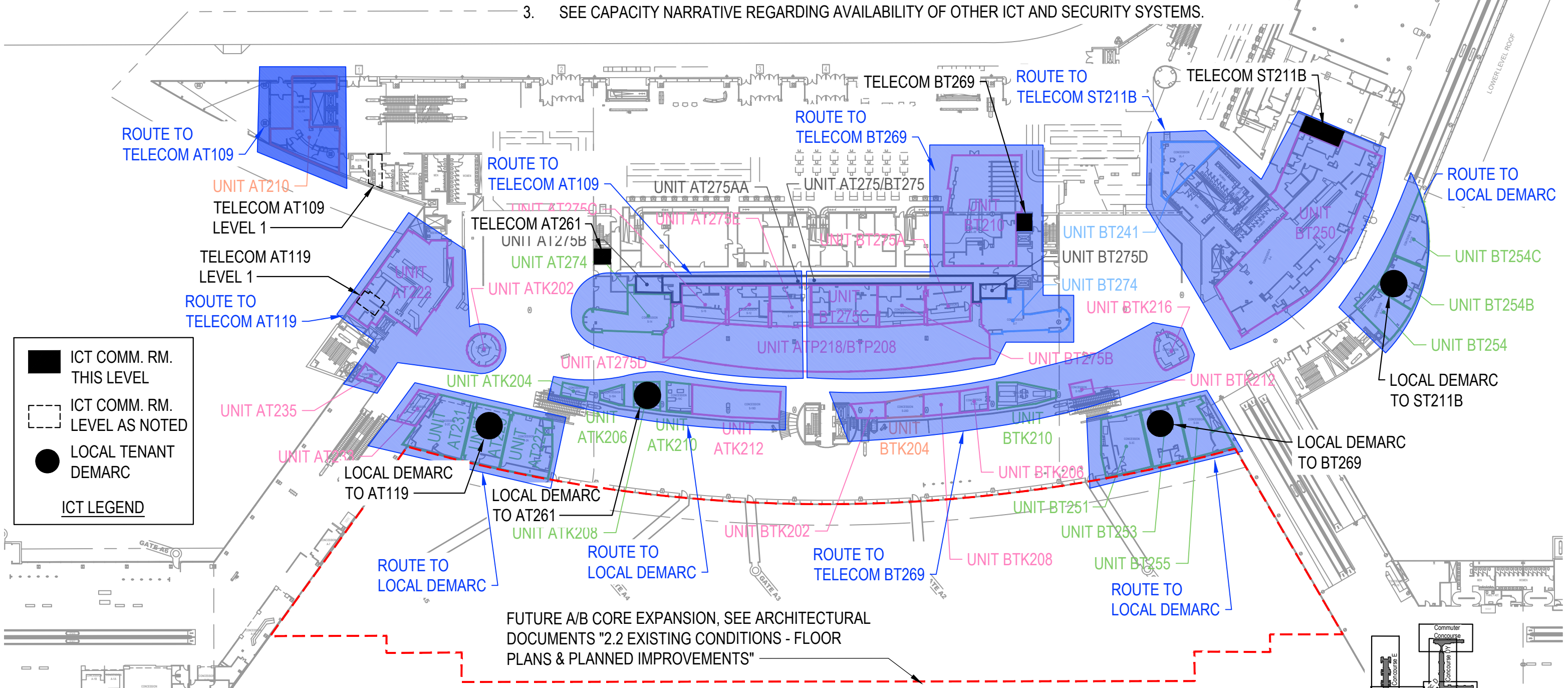

**ICT LEGEND**

- ICT COMM. RM. THIS LEVEL
- ICT COMM. RM. LEVEL AS NOTED
- LOCAL TENANT DEMARC

**Concession Category**

<span style="border: 1px solid pink; display: inline-block; width: 15px; height: 10px;"></span> Food Service	<span style="border: 1px solid orange; display: inline-block; width: 15px; height: 10px;"></span> Services
<span style="border: 1px solid blue; display: inline-block; width: 15px; height: 10px;"></span> Convenience Retail	<span style="border: 1px solid grey; display: inline-block; width: 15px; height: 10px;"></span> Support Space
<span style="border: 1px solid green; display: inline-block; width: 15px; height: 10px;"></span> Specialty Retail	<span style="border: 1px solid purple; display: inline-block; width: 15px; height: 10px;"></span> MAA Controlled
<span style="border: 1px solid yellow; display: inline-block; width: 15px; height: 10px;"></span> Vending	

FUTURE A/B CORE EXPANSION, SEE ARCHITECTURAL DOCUMENTS "2.2 EXISTING CONDITIONS - FLOOR PLANS & PLANNED IMPROVEMENTS"

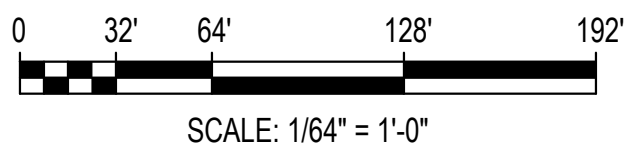
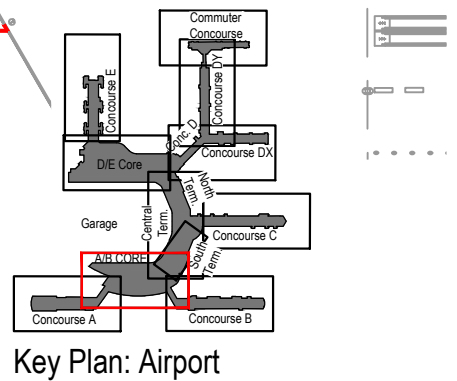

# Concourse B - Upper Level (Level 2)

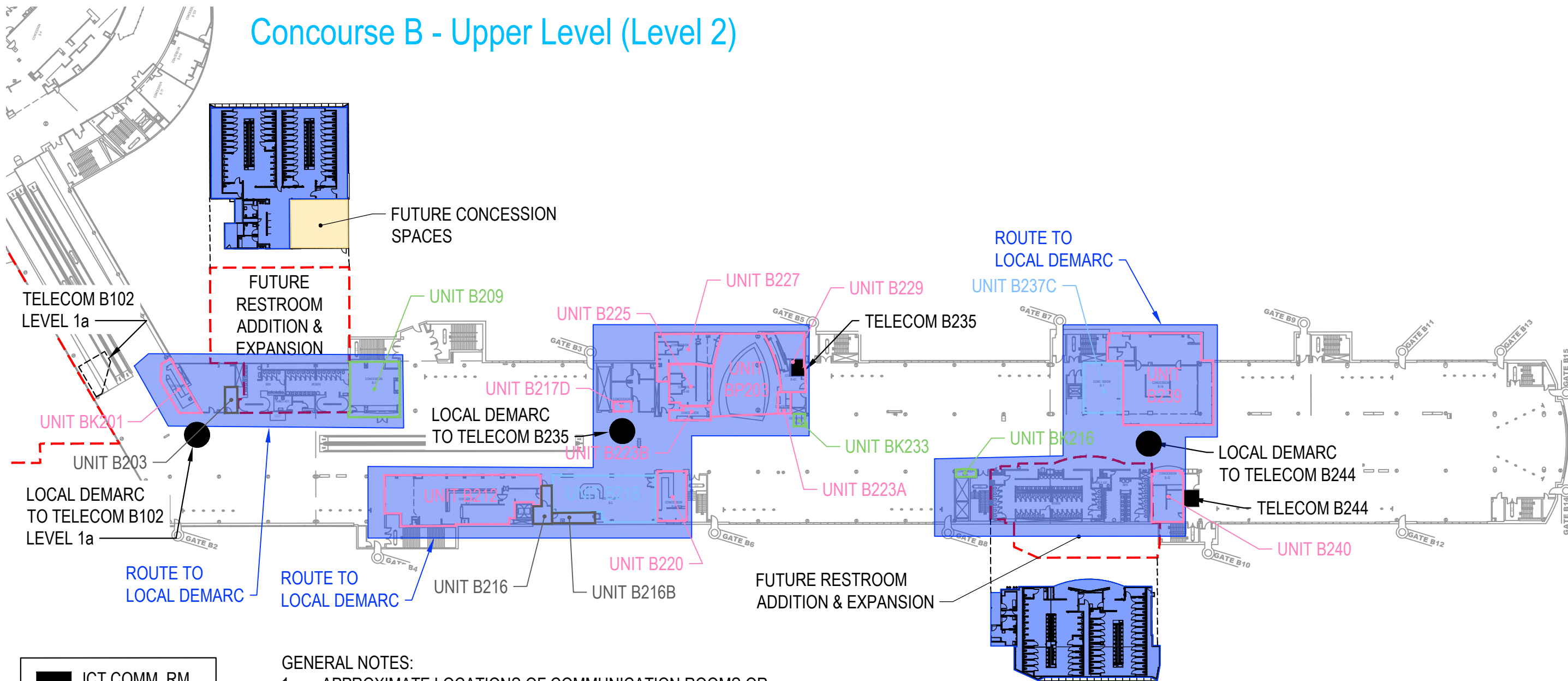

**ICT LEGEND**

- ICT COMM. RM. THIS LEVEL
- ICT COMM. RM. LEVEL AS NOTED
- LOCAL TENANT DEMARC

- GENERAL NOTES:**
1. APPROXIMATE LOCATIONS OF COMMUNICATION ROOMS OR DEMARCATION POINTS USED BY CONCESSIONS ARE SHOWN FOR REFERENCE PURPOSES. TENANT TO ROUTE CABLES TO NEAREST NOTED LOCATION AND AS COORDINATED WITH MAA DEPARTMENT OF AIRPORT TECHNOLOGY (DAT).
  2. SEE CAPACITY NARRATIVE FOR TENANT'S RESPONSIBILITY FOR SYSTEM CABLING OF ICT SYSTEMS.
  3. SEE CAPACITY NARRATIVE REGARDING AVAILABILITY OF OTHER ICT AND SECURITY SYSTEMS.

**Concession Category**

<span style="display: inline-block; width: 15px; height: 15px; border: 1px solid pink; margin-right: 5px;"></span> Food Service	<span style="display: inline-block; width: 15px; height: 15px; border: 1px solid orange; margin-right: 5px;"></span> Services
<span style="display: inline-block; width: 15px; height: 15px; border: 1px solid blue; margin-right: 5px;"></span> Convenience Retail	<span style="display: inline-block; width: 15px; height: 15px; border: 1px solid grey; margin-right: 5px;"></span> Support Space
<span style="display: inline-block; width: 15px; height: 15px; border: 1px solid green; margin-right: 5px;"></span> Specialty Retail	<span style="display: inline-block; width: 15px; height: 15px; border: 1px solid purple; margin-right: 5px;"></span> MAA Controlled
<span style="display: inline-block; width: 15px; height: 15px; border: 1px solid yellow; margin-right: 5px;"></span> Vending	

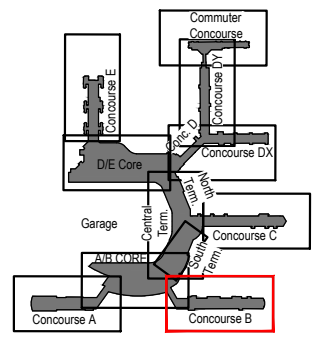
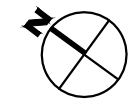
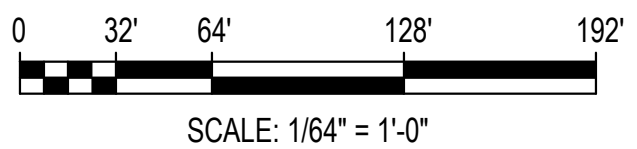

Key Plan: Airport



# Terminal South, Center, North - Upper Level (Level 2)

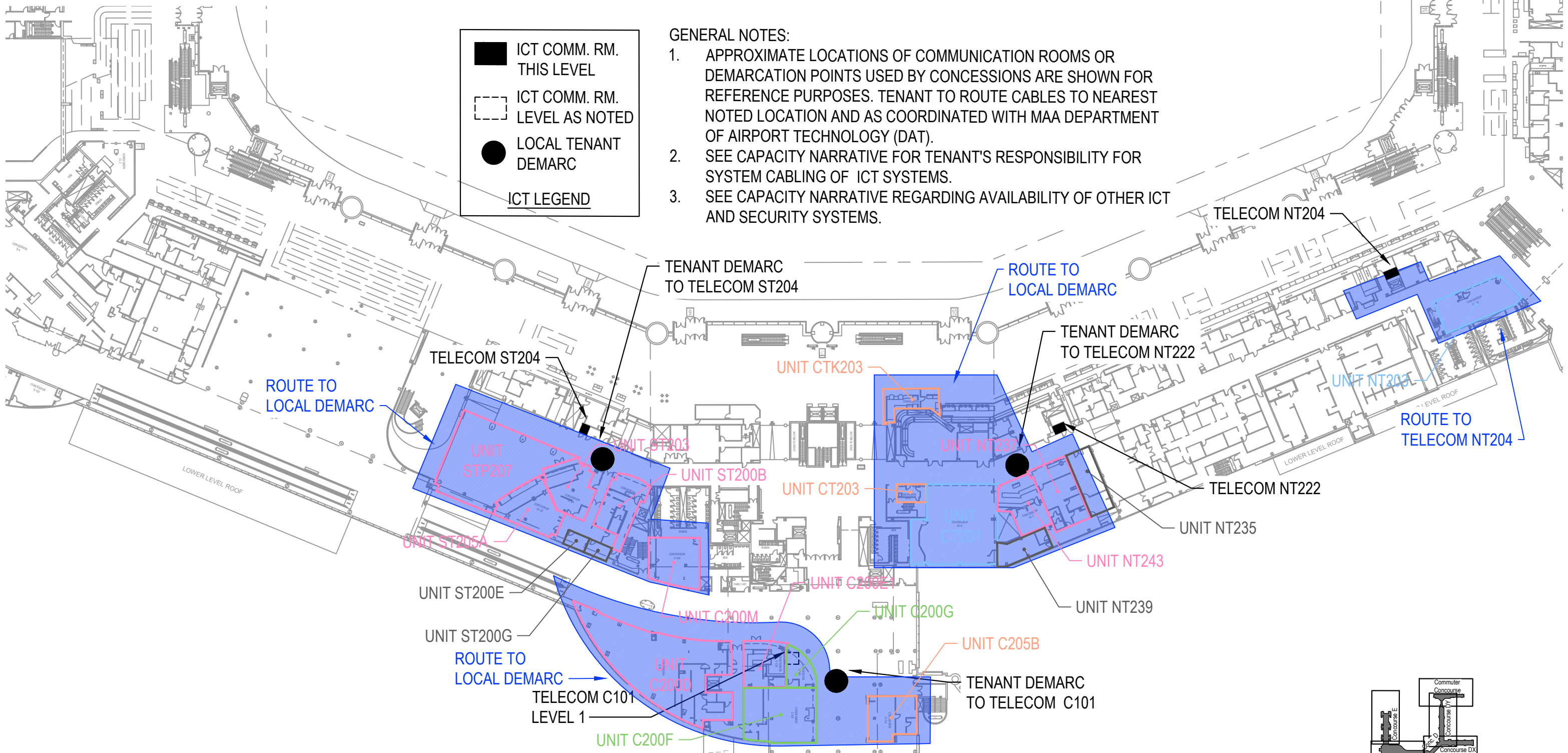

**ICT LEGEND**

- ICT COMM. RM. THIS LEVEL
- ICT COMM. RM. LEVEL AS NOTED
- LOCAL TENANT DEMARC

- GENERAL NOTES:**
1. APPROXIMATE LOCATIONS OF COMMUNICATION ROOMS OR DEMARCATION POINTS USED BY CONCESSIONS ARE SHOWN FOR REFERENCE PURPOSES. TENANT TO ROUTE CABLES TO NEAREST NOTED LOCATION AND AS COORDINATED WITH MAA DEPARTMENT OF AIRPORT TECHNOLOGY (DAT).
  2. SEE CAPACITY NARRATIVE FOR TENANT'S RESPONSIBILITY FOR SYSTEM CABLING OF ICT SYSTEMS.
  3. SEE CAPACITY NARRATIVE REGARDING AVAILABILITY OF OTHER ICT AND SECURITY SYSTEMS.

**Concession Category**

■ Food Service	■ Services
■ Convenience Retail	■ Support Space
■ Specialty Retail	■ MAA Controlled
■ Vending	

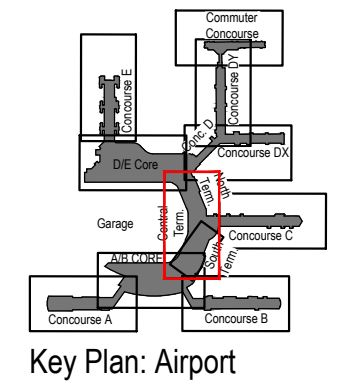
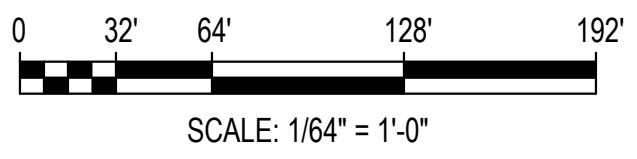

# Concourse C - Upper Level (Level 2)

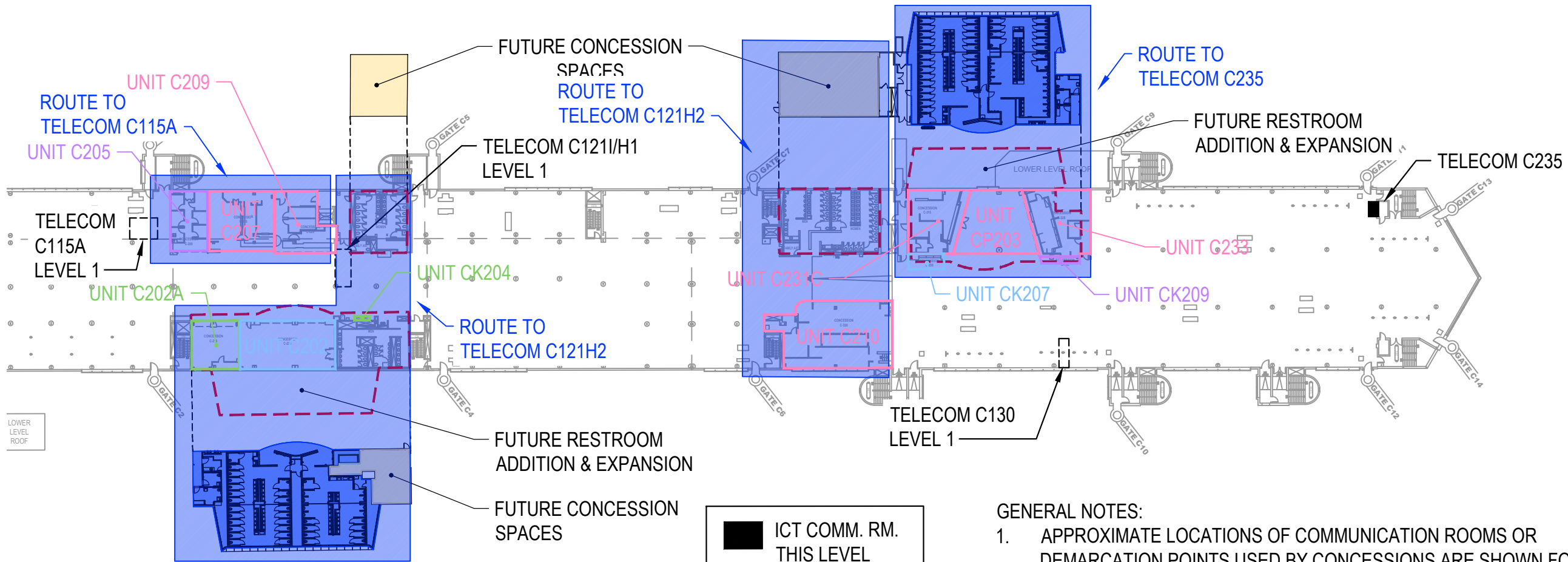

LOWER LEVEL ROOF

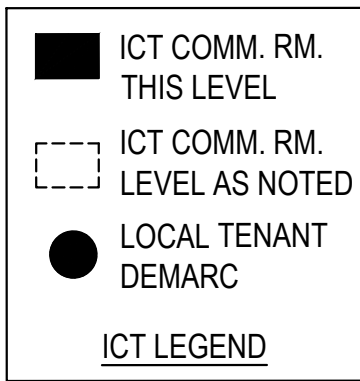

- GENERAL NOTES:**
1. APPROXIMATE LOCATIONS OF COMMUNICATION ROOMS OR DEMARCATION POINTS USED BY CONCESSIONS ARE SHOWN FOR REFERENCE PURPOSES. TENANT TO ROUTE CABLES TO NEAREST NOTED LOCATION AND AS COORDINATED WITH MAA DEPARTMENT OF AIRPORT TECHNOLOGY (DAT).
  2. SEE CAPACITY NARRATIVE FOR TENANT'S RESPONSIBILITY FOR SYSTEM CABLING OF ICT SYSTEMS.
  3. SEE CAPACITY NARRATIVE REGARDING AVAILABILITY OF OTHER ICT AND SECURITY SYSTEMS.

**Concession Category**

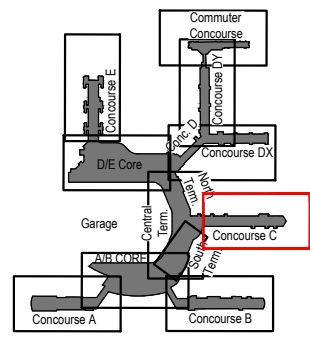
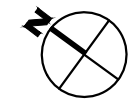
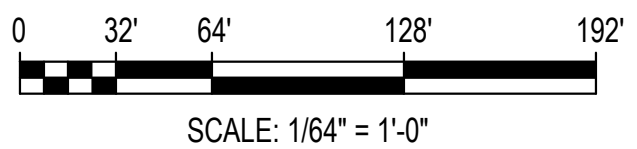

Key Plan: Airport



# Concourse D, DX - Upper Level (Level 2)

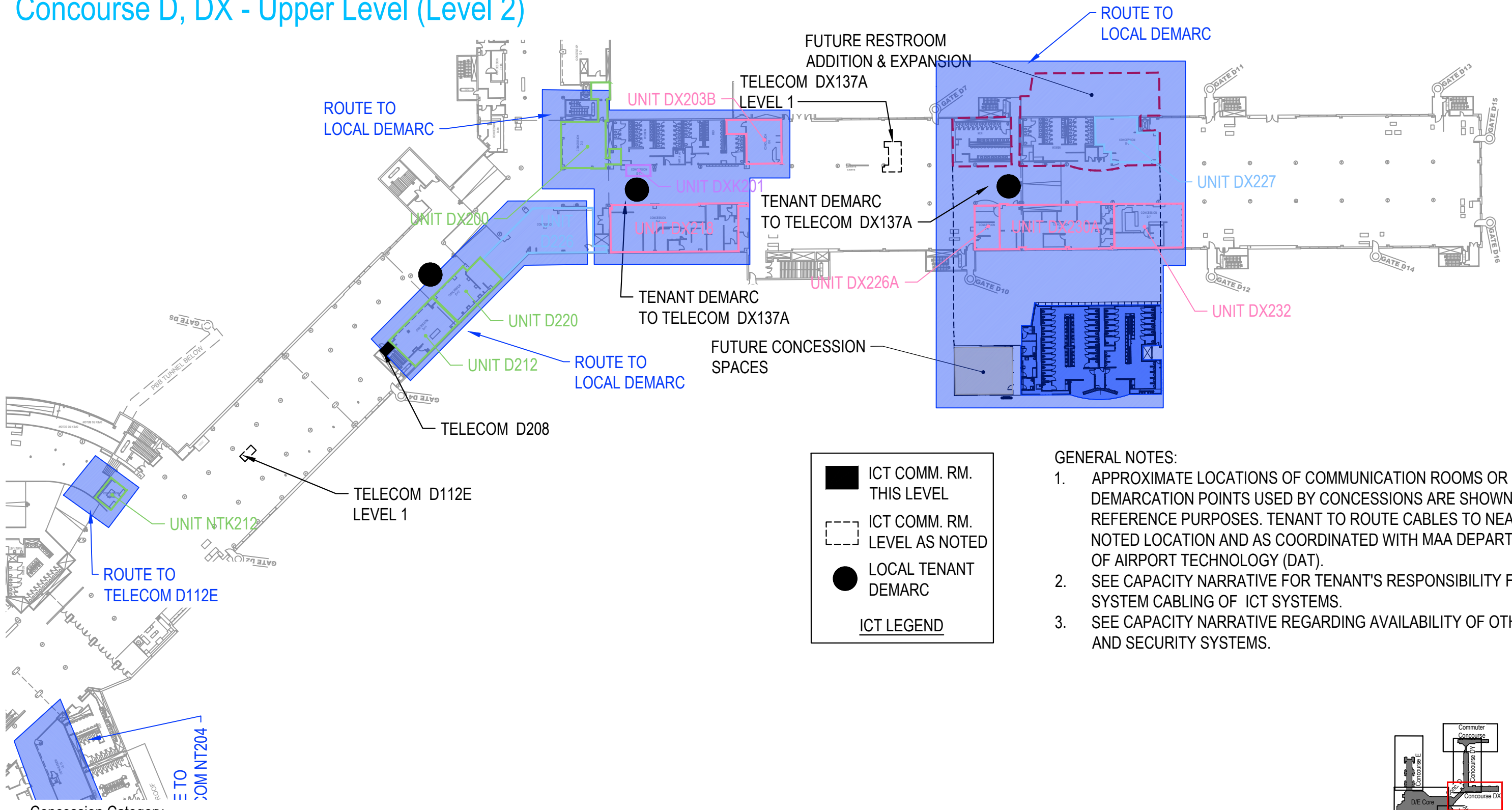

**ICT LEGEND**

- ICT COMM. RM. THIS LEVEL
- ICT COMM. RM. LEVEL AS NOTED
- LOCAL TENANT DEMARC

- GENERAL NOTES:**
1. APPROXIMATE LOCATIONS OF COMMUNICATION ROOMS OR DEMARCATION POINTS USED BY CONCESSIONS ARE SHOWN FOR REFERENCE PURPOSES. TENANT TO ROUTE CABLES TO NEAREST NOTED LOCATION AND AS COORDINATED WITH MAA DEPARTMENT OF AIRPORT TECHNOLOGY (DAT).
  2. SEE CAPACITY NARRATIVE FOR TENANT'S RESPONSIBILITY FOR SYSTEM CABLING OF ICT SYSTEMS.
  3. SEE CAPACITY NARRATIVE REGARDING AVAILABILITY OF OTHER ICT AND SECURITY SYSTEMS.

**Concession Category**

	Food Service		Services
	Convenience Retail		Support Space
	Specialty Retail		MAA Controlled
	Vending		

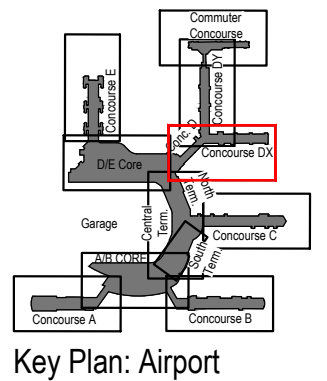
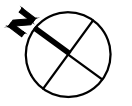
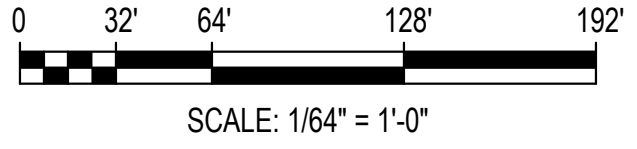

# Concourse DY - Upper Level (Level 2)

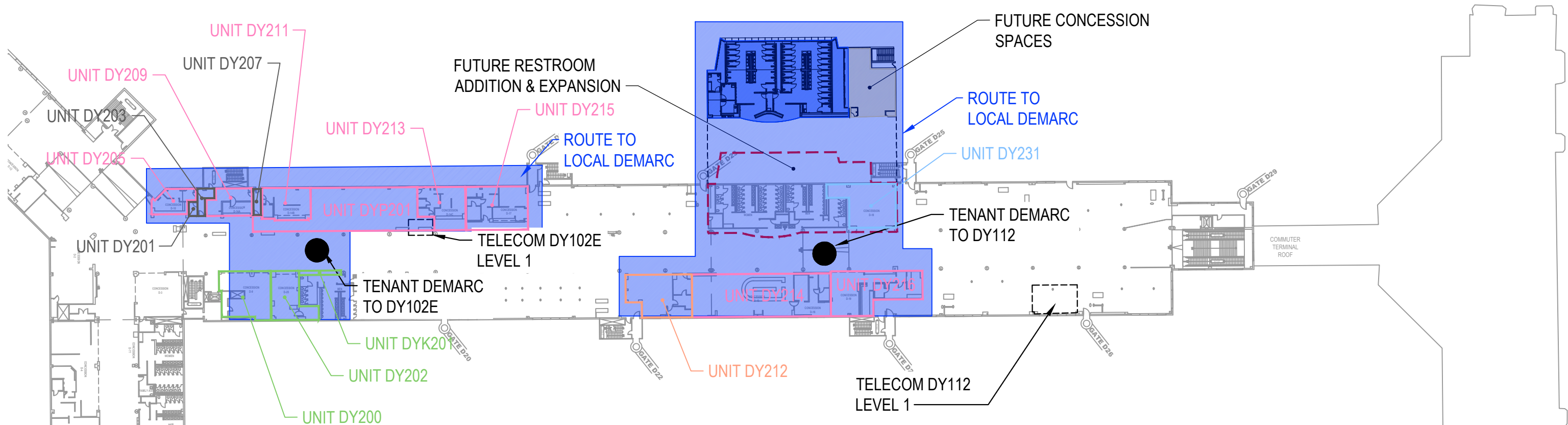

FUTURE RESTROOM  
ADDITION & EXPANSION

**ICT LEGEND**

- ICT COMM. RM. THIS LEVEL
- ICT COMM. RM. LEVEL AS NOTED
- LOCAL TENANT DEMARC

**GENERAL NOTES:**

1. APPROXIMATE LOCATIONS OF COMMUNICATION ROOMS OR DEMARCATION POINTS USED BY CONCESSIONS ARE SHOWN FOR REFERENCE PURPOSES. TENANT TO ROUTE CABLES TO NEAREST NOTED LOCATION AND AS COORDINATED WITH MAA DEPARTMENT OF AIRPORT TECHNOLOGY (DAT).
2. SEE CAPACITY NARRATIVE FOR TENANT'S RESPONSIBILITY FOR SYSTEM CABLING OF ICT SYSTEMS.
3. SEE CAPACITY NARRATIVE REGARDING AVAILABILITY OF OTHER ICT AND SECURITY SYSTEMS.

**Concession Category**

<span style="display: inline-block; width: 15px; height: 15px; border: 1px solid pink; margin-right: 5px;"></span> Food Service	<span style="display: inline-block; width: 15px; height: 15px; border: 1px solid orange; margin-right: 5px;"></span> Services
<span style="display: inline-block; width: 15px; height: 15px; border: 1px solid blue; margin-right: 5px;"></span> Convenience Retail	<span style="display: inline-block; width: 15px; height: 15px; border: 1px solid grey; margin-right: 5px;"></span> Support Space
<span style="display: inline-block; width: 15px; height: 15px; border: 1px solid green; margin-right: 5px;"></span> Specialty Retail	<span style="display: inline-block; width: 15px; height: 15px; border: 1px solid purple; margin-right: 5px;"></span> MAA Controlled
<span style="display: inline-block; width: 15px; height: 15px; border: 1px solid yellow; margin-right: 5px;"></span> Vending	

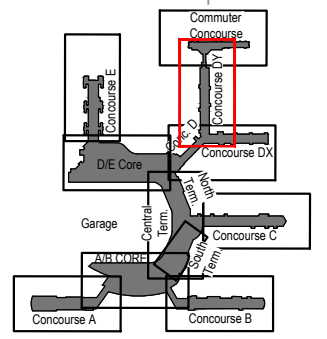

Key Plan: Airport

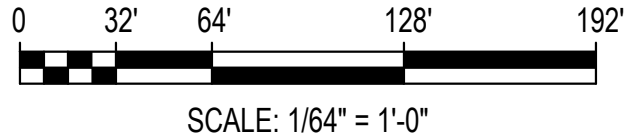

# D/E Core - Upper Level (Level 2)

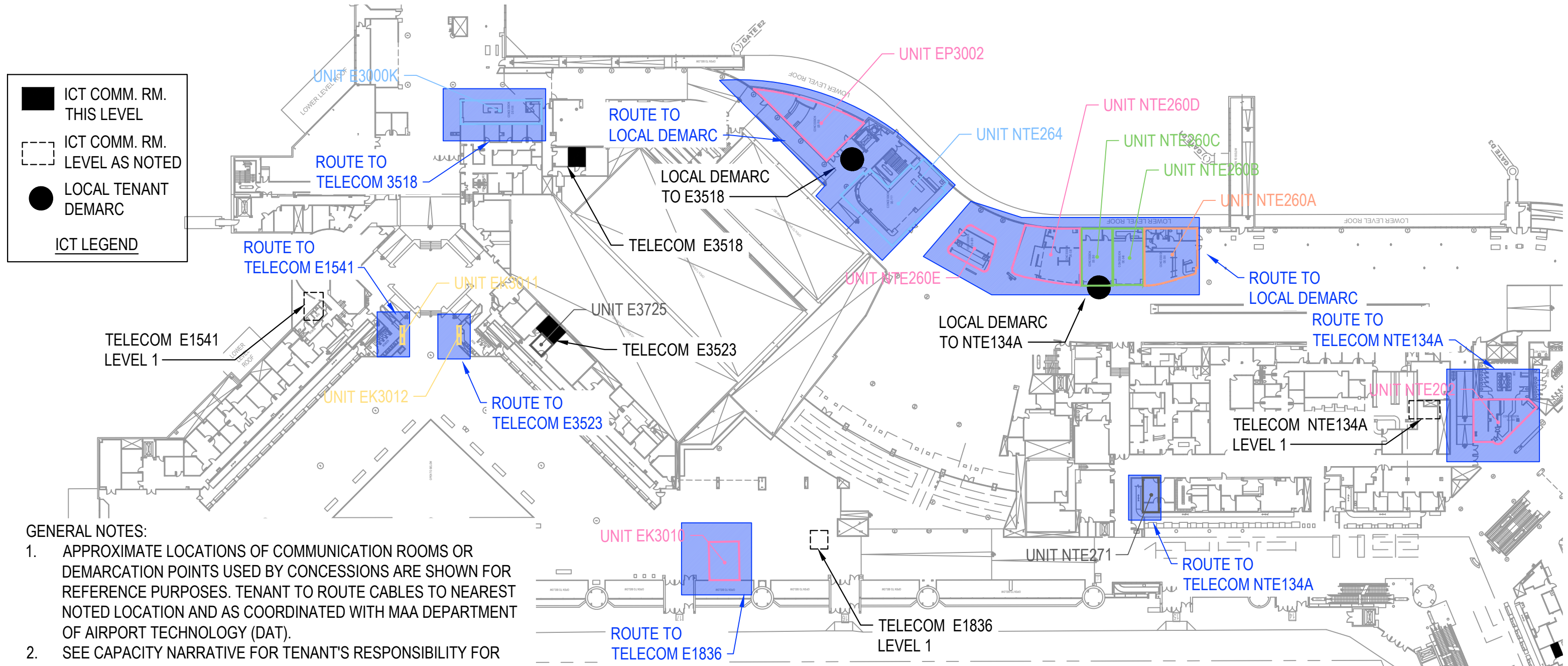

**ICT LEGEND**

- ICT COMM. RM. THIS LEVEL
- ICT COMM. RM. LEVEL AS NOTED
- LOCAL TENANT DEMARC

**GENERAL NOTES:**

1. APPROXIMATE LOCATIONS OF COMMUNICATION ROOMS OR DEMARCATION POINTS USED BY CONCESSIONS ARE SHOWN FOR REFERENCE PURPOSES. TENANT TO ROUTE CABLES TO NEAREST NOTED LOCATION AND AS COORDINATED WITH MAA DEPARTMENT OF AIRPORT TECHNOLOGY (DAT).
2. SEE CAPACITY NARRATIVE FOR TENANT'S RESPONSIBILITY FOR SYSTEM CABLING OF ICT SYSTEMS.
3. SEE CAPACITY NARRATIVE REGARDING AVAILABILITY OF OTHER ICT AND SECURITY SYSTEMS.

**Concession Category**

<ul style="list-style-type: none"> <li><span style="display: inline-block; width: 15px; height: 15px; border: 1px solid pink; margin-right: 5px;"></span> Food Service</li> <li><span style="display: inline-block; width: 15px; height: 15px; border: 1px solid blue; margin-right: 5px;"></span> Convenience Retail</li> <li><span style="display: inline-block; width: 15px; height: 15px; border: 1px solid green; margin-right: 5px;"></span> Specialty Retail</li> <li><span style="display: inline-block; width: 15px; height: 15px; border: 1px solid orange; margin-right: 5px;"></span> Vending</li> </ul>	<ul style="list-style-type: none"> <li><span style="display: inline-block; width: 15px; height: 15px; border: 1px solid orange; margin-right: 5px;"></span> Services</li> <li><span style="display: inline-block; width: 15px; height: 15px; border: 1px solid black; margin-right: 5px;"></span> Support Space</li> <li><span style="display: inline-block; width: 15px; height: 15px; border: 1px solid purple; margin-right: 5px;"></span> MAA Controlled</li> </ul>
--	---

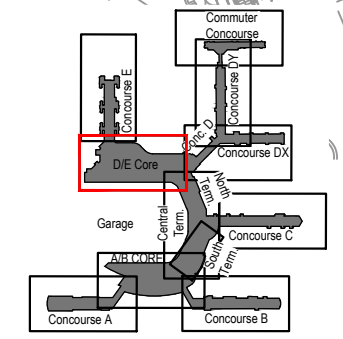

SCALE: 1/64" = 1'-0"





# Concourse E - Upper Level (Level 2)

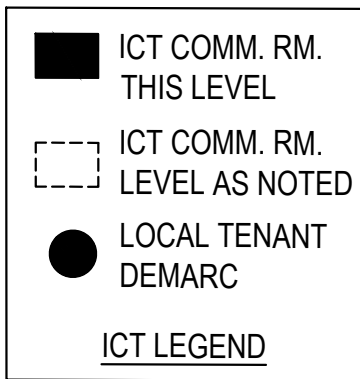
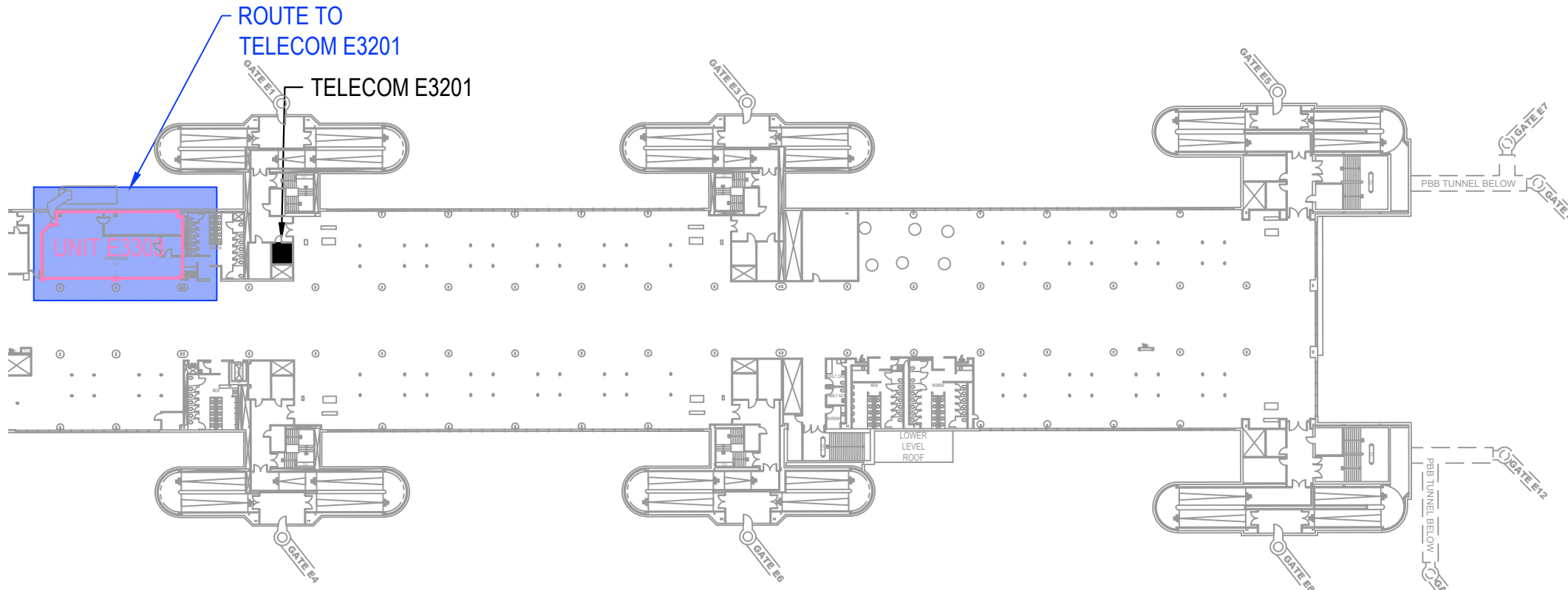

**GENERAL NOTES:**

1. APPROXIMATE LOCATIONS OF COMMUNICATION ROOMS OR DEMARCATION POINTS USED BY CONCESSIONS ARE SHOWN FOR REFERENCE PURPOSES. TENANT TO ROUTE CABLES TO NEAREST NOTED LOCATION AND AS COORDINATED WITH MAA DEPARTMENT OF AIRPORT TECHNOLOGY (DAT).
2. SEE CAPACITY NARRATIVE FOR TENANT'S RESPONSIBILITY FOR SYSTEM CABLING OF ICT SYSTEMS.
3. SEE CAPACITY NARRATIVE REGARDING AVAILABILITY OF OTHER ICT AND SECURITY SYSTEMS.

**Concession Category**



SCALE: 1/64" = 1'-0"

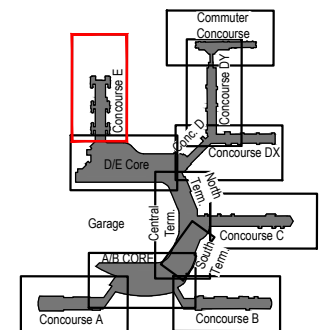

Key Plan: Airport



# Terminal Observation Gallery - Upper Level Mezzanine

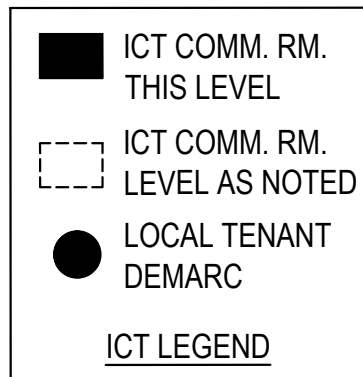
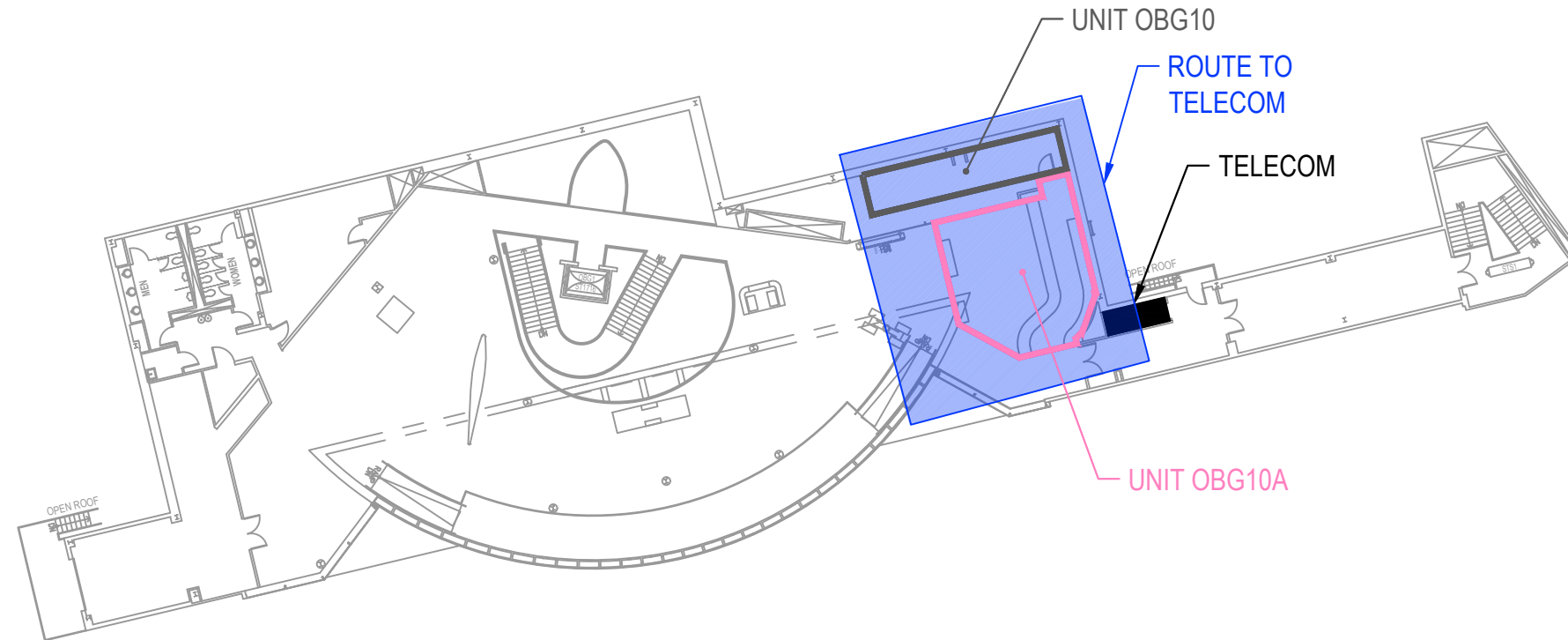

### GENERAL NOTES:

1. APPROXIMATE LOCATIONS OF COMMUNICATION ROOMS OR DEMARCATION POINTS ARE SHOWN FOR REFERENCE PURPOSES. TENANT TO ROUTE CABLES TO NEAREST NOTED LOCATION AND AS COORDINATED WITH MAA DEPARTMENT OF AIRPORT TECHNOLOGY (DAT).
2. SEE CAPACITY NARRATIVE FOR TENANT'S RESPONSIBILITY FOR SYSTEM CABLING OF ICT SYSTEMS.
3. SEE CAPACITY NARRATIVE REGARDING AVAILABILITY OF OTHER ICT AND SECURITY SYSTEMS.

### Concession Category

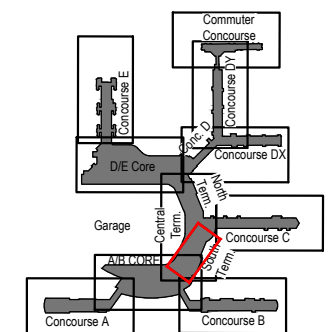

Key Plan: Airport



SCALE: 1/32" = 1'-0"



# Concourse A - Ground Level (Level 1a)

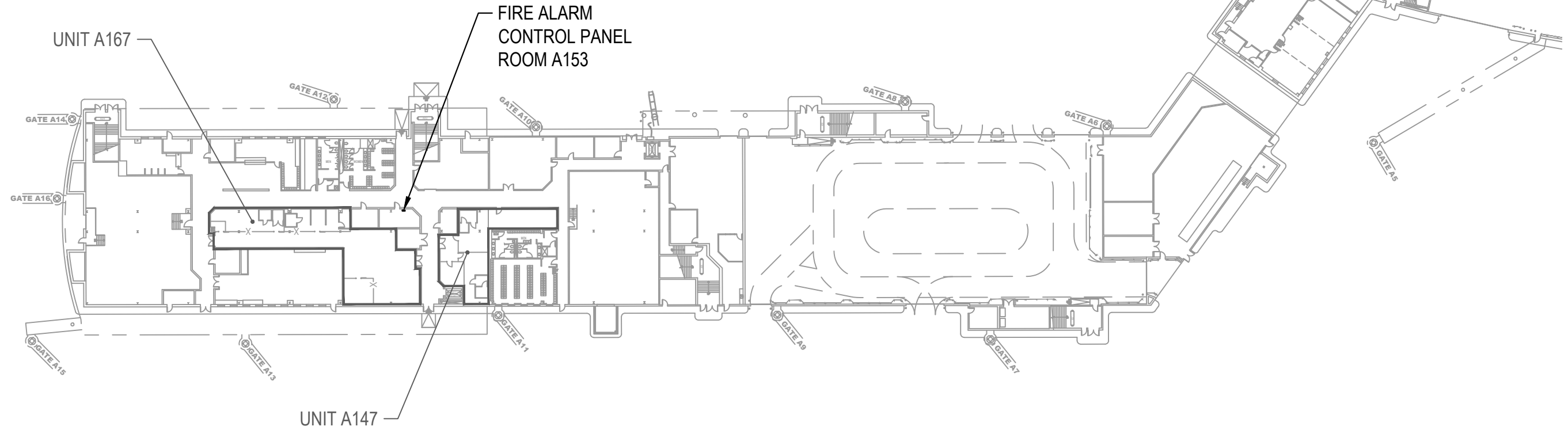

## Concession Category

- |   |                    |   |                |
|---|--------------------|---|----------------|
|  | Food Service       |  | Services       |
|  | Convenience Retail |  | Support Space  |
|  | Specialty Retail   |  | MAA Controlled |
|  | Vending            |   |                |

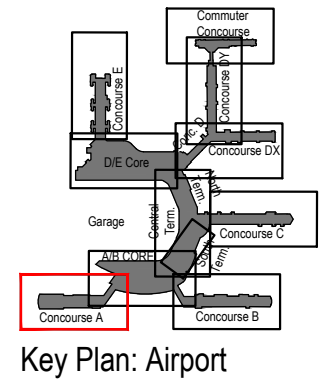
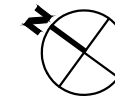
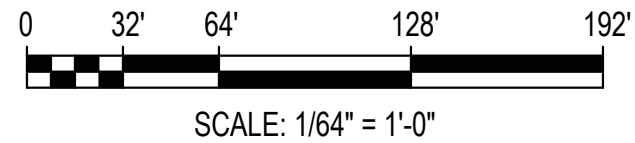

# A/B Core - Ground Level (Level 1a)

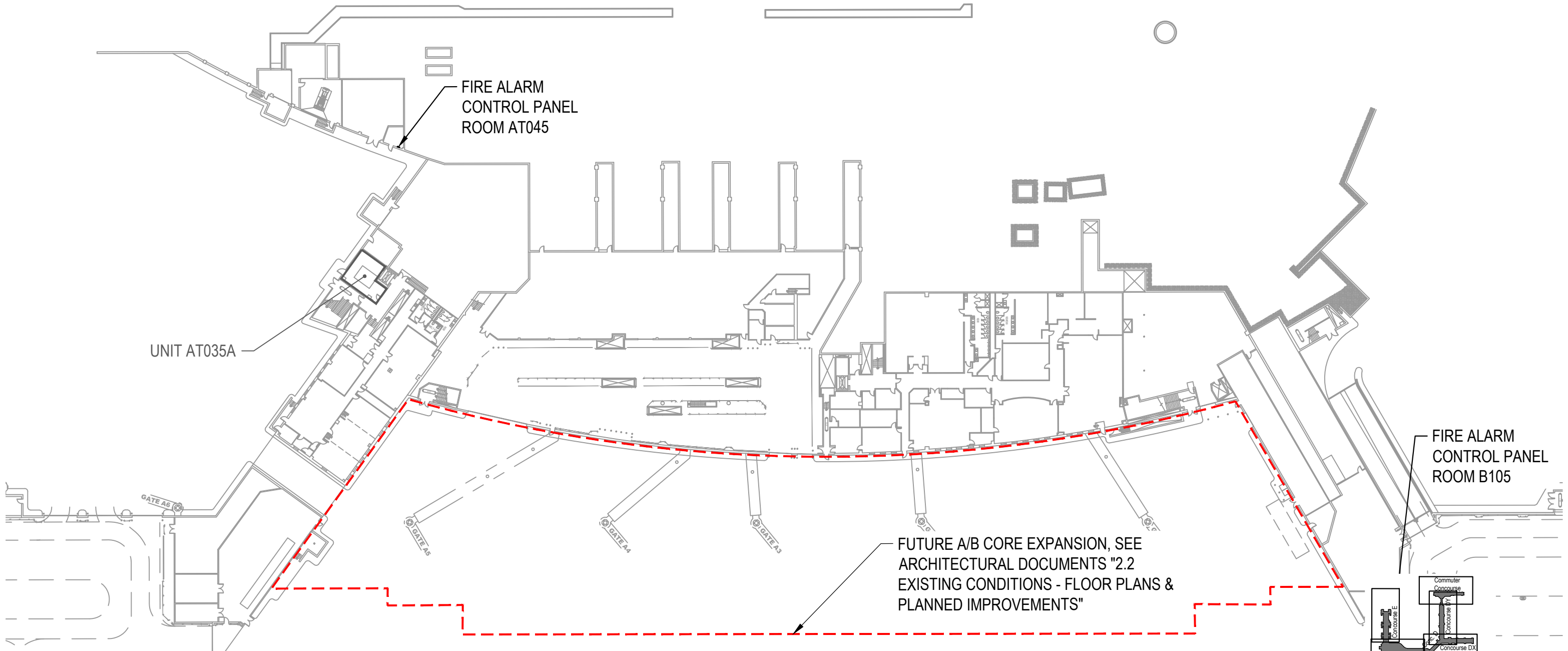

**Concession Category**

- |   |                    |   |                |
|---|--------------------|---|----------------|
|  | Food Service       |  | Services       |
|  | Convenience Retail |  | Support Space  |
|  | Specialty Retail   |  | MAA Controlled |
|  | Vending            |   |                |

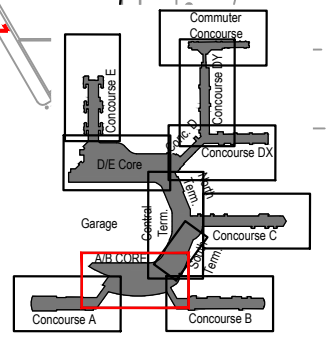

SCALE: 1/64" = 1'-0"



# Concourse B - Ground Level (Level 1a)

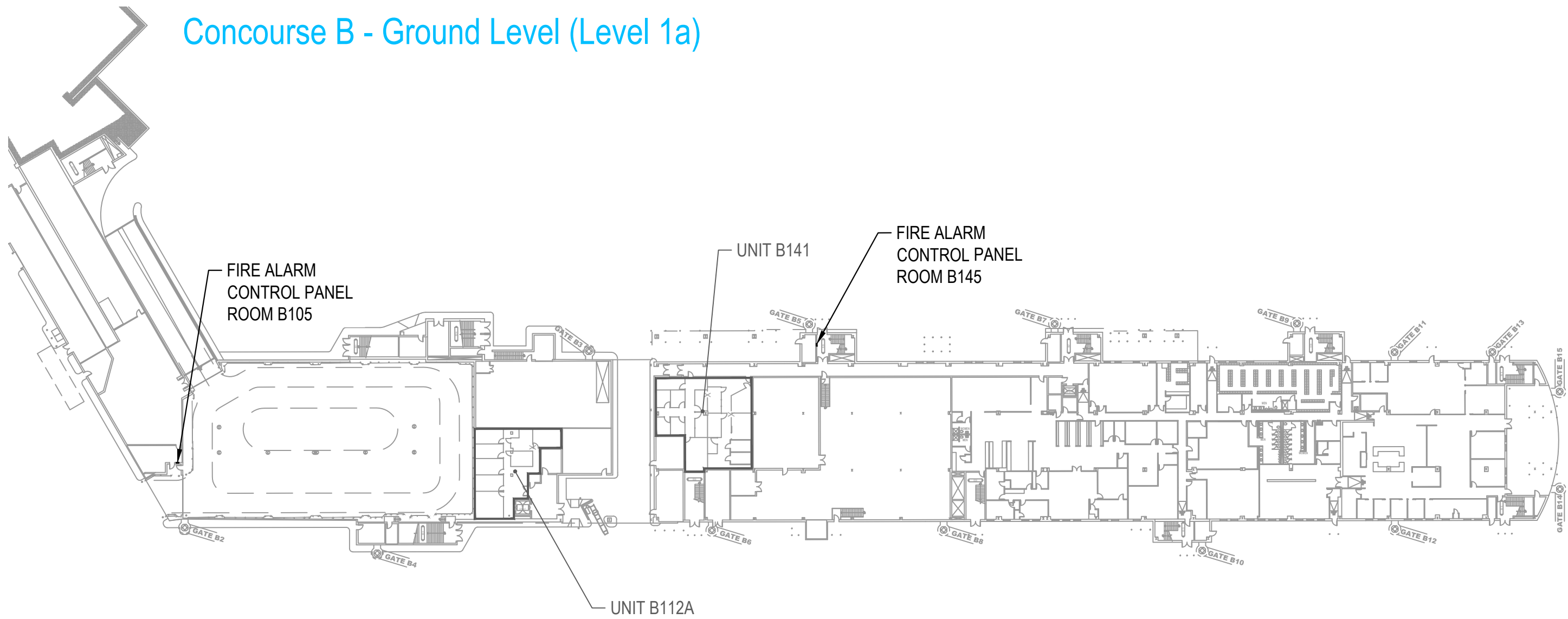

## Concession Category

- |   |                    |   |                |
|---|--------------------|---|----------------|
|  | Food Service       |  | Services       |
|  | Convenience Retail |  | Support Space  |
|  | Specialty Retail   |  | MAA Controlled |
|  | Vending            |   |                |



SCALE: 1/64" = 1'-0"

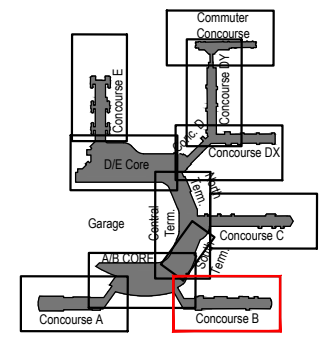

Key Plan: Airport



# A/B Core - Lower Level (Level 1)

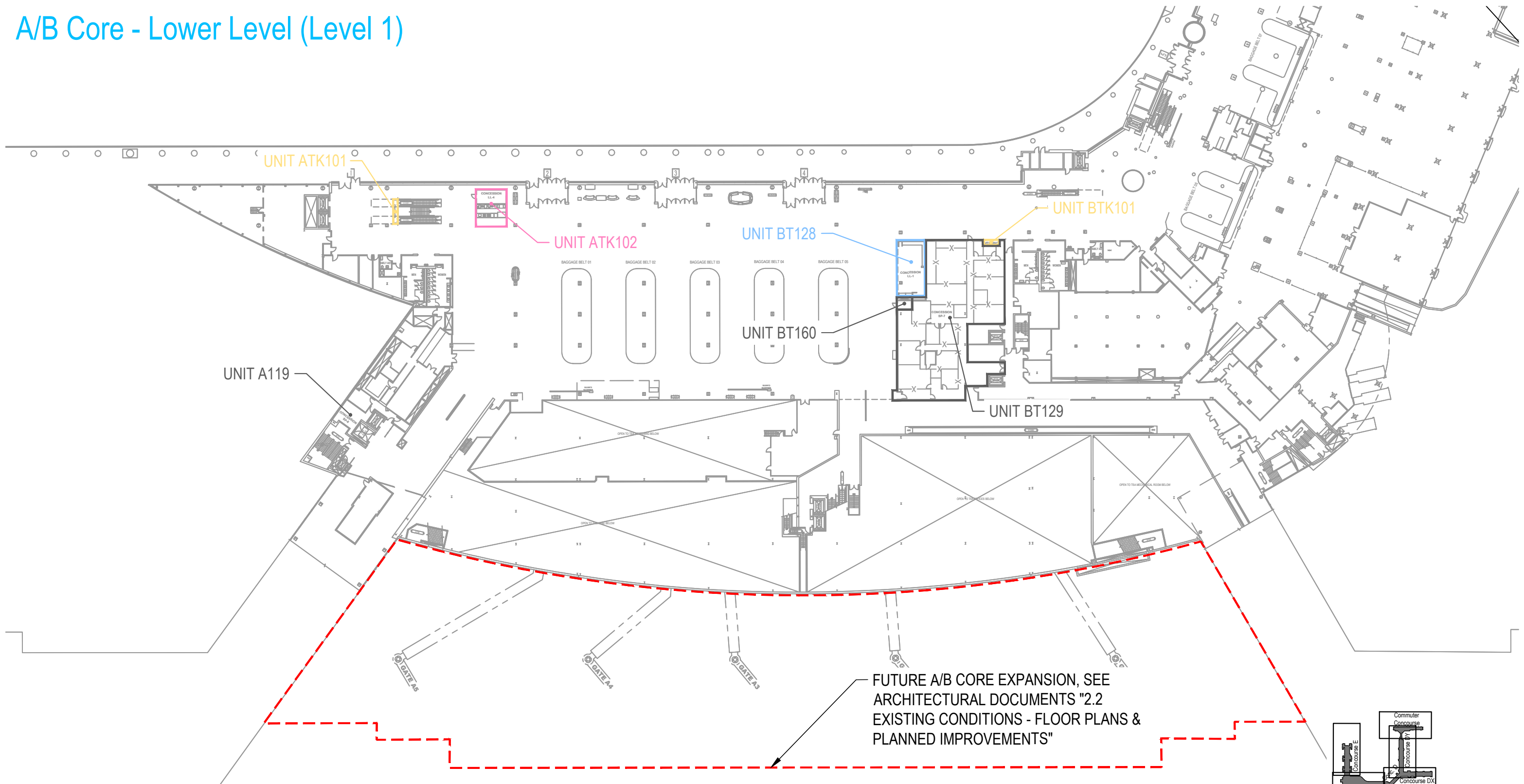

FUTURE A/B CORE EXPANSION, SEE ARCHITECTURAL DOCUMENTS "2.2 EXISTING CONDITIONS - FLOOR PLANS & PLANNED IMPROVEMENTS"

### Concession Category

- |  |  |
|--|--|
| <span style="border: 1px solid pink; display: inline-block; width: 15px; height: 10px;"></span> Food Service       | <span style="border: 1px solid orange; display: inline-block; width: 15px; height: 10px;"></span> Services       |
| <span style="border: 1px solid blue; display: inline-block; width: 15px; height: 10px;"></span> Convenience Retail | <span style="border: 1px solid grey; display: inline-block; width: 15px; height: 10px;"></span> Support Space    |
| <span style="border: 1px solid green; display: inline-block; width: 15px; height: 10px;"></span> Specialty Retail  | <span style="border: 1px solid purple; display: inline-block; width: 15px; height: 10px;"></span> MAA Controlled |
| <span style="border: 1px solid yellow; display: inline-block; width: 15px; height: 10px;"></span> Vending          |  |

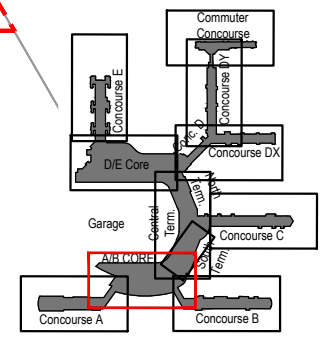

Key Plan: Airport



SCALE: 1/64" = 1'-0"

# Terminal South, Center, North - Lower Level (Level 1)

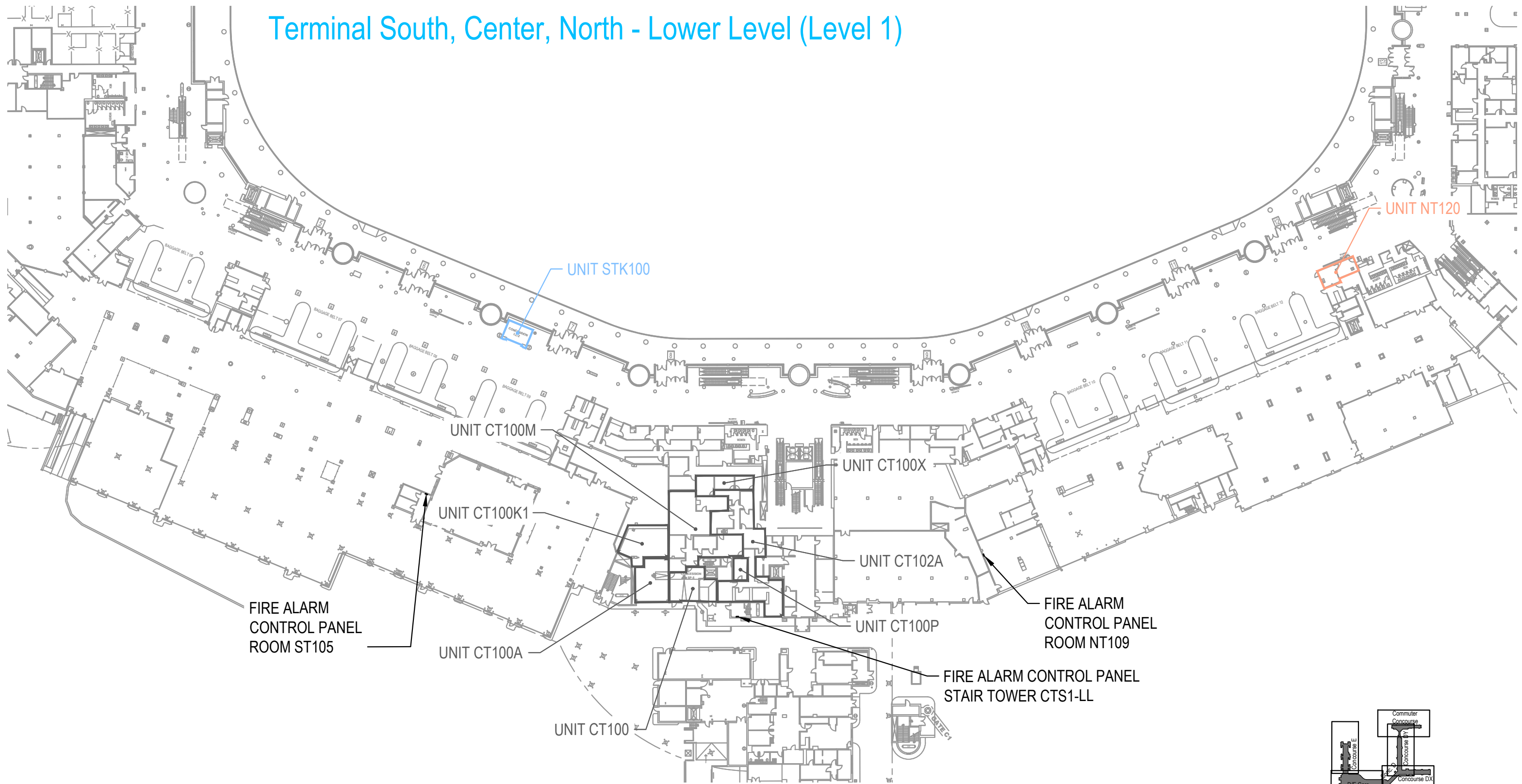

### Concession Category

- |   |                    |   |                |
|---|--------------------|---|----------------|
|  | Food Service       |  | Services       |
|  | Convenience Retail |  | Support Space  |
|  | Specialty Retail   |  | MAA Controlled |
|  | Vending            |   |                |



SCALE: 1/64" = 1'-0"

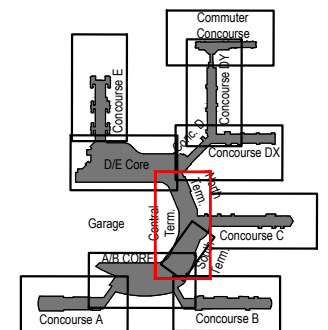

Key Plan: Airport

# Concourse C - Lower Level (Level 1)

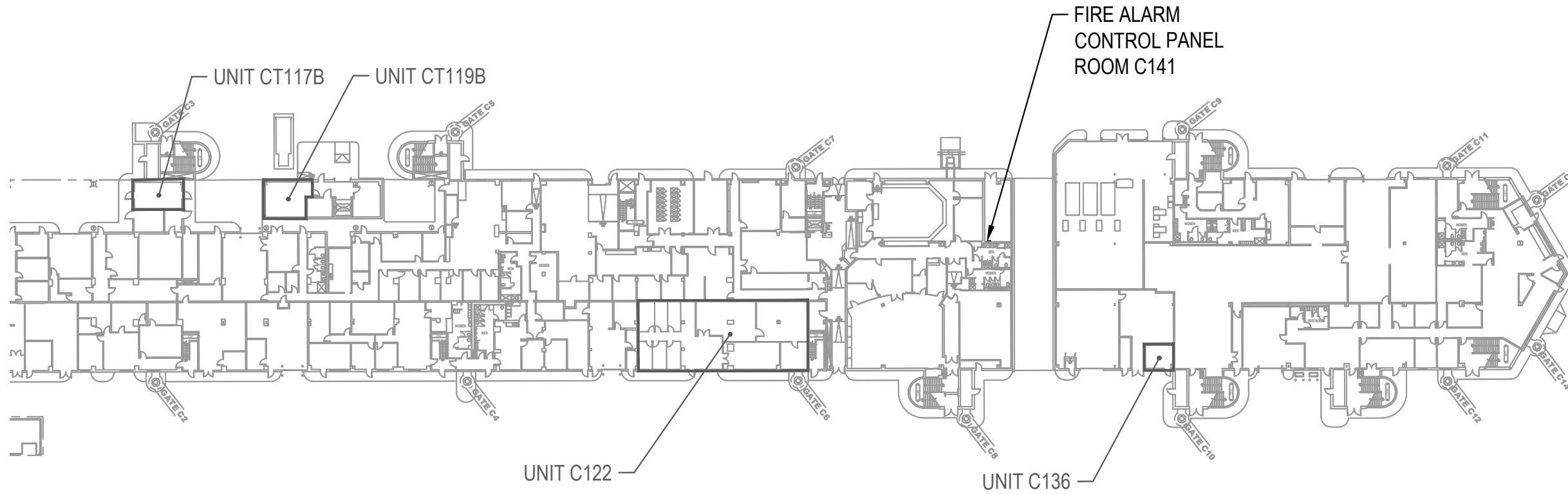

## Concession Category

- |   |                    |   |                |
|---|--------------------|---|----------------|
|  | Food Service       |  | Services       |
|  | Convenience Retail |  | Support Space  |
|  | Specialty Retail   |  | MAA Controlled |
|  | Vending            |   |                |



SCALE: 1/64" = 1'-0"

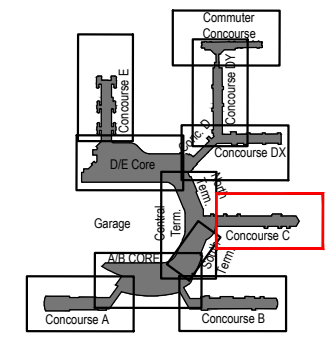

Key Plan: Airport

# Concourse D, DX - Lower Level (Level 1)

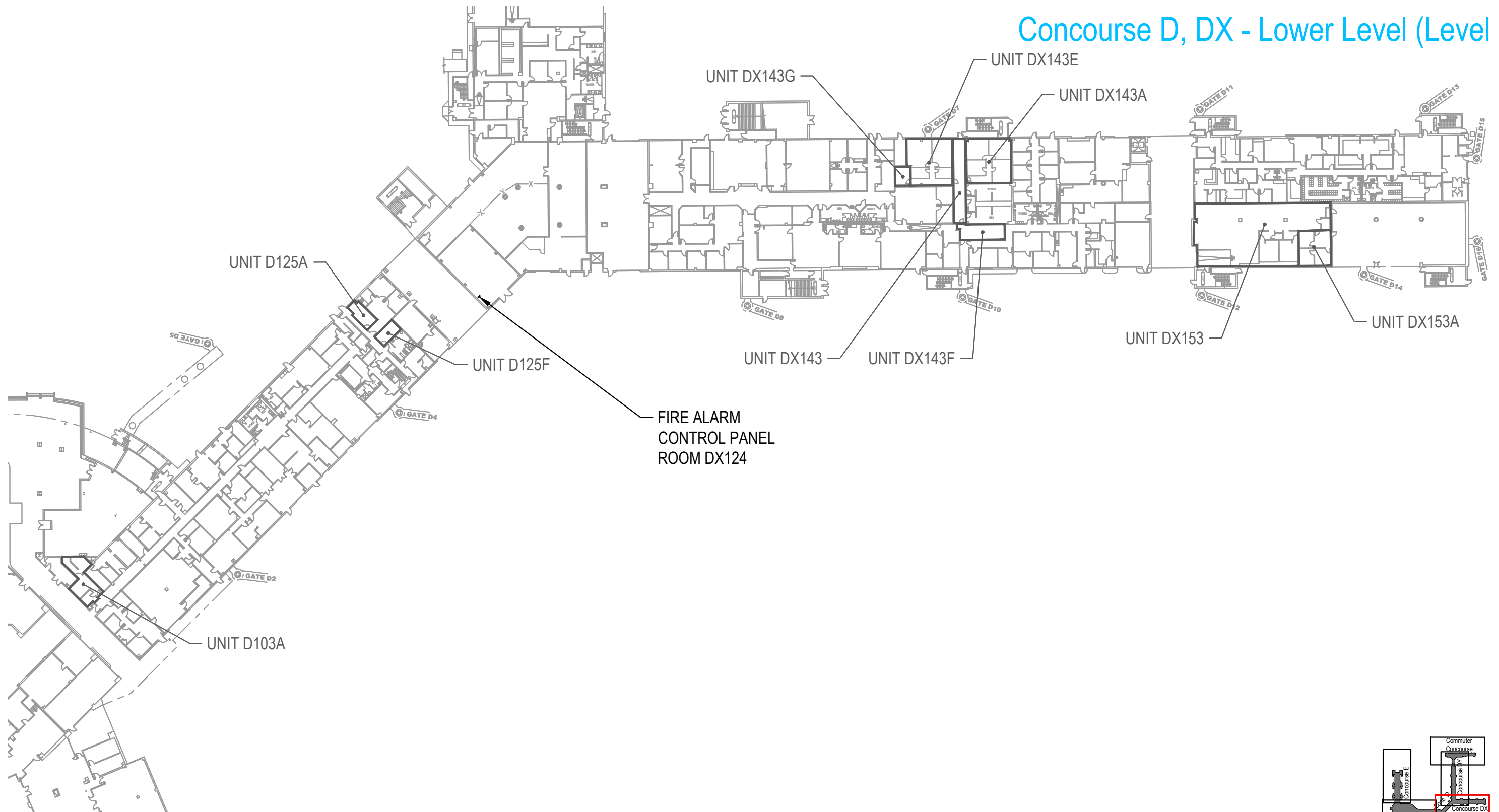

**Concession Category**

- |   |                    |   |                |
|---|--------------------|---|----------------|
|  | Food Service       |  | Services       |
|  | Convenience Retail |  | Support Space  |
|  | Specialty Retail   |  | MAA Controlled |
|   | Vending            |   |                |



SCALE: 1/64" = 1'-0"

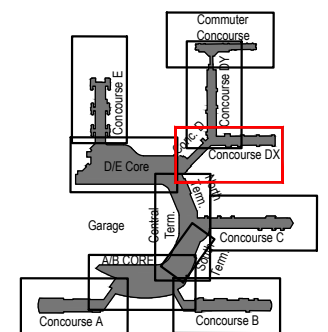

Key Plan: Airport



# Concourse DY - Lower Level (Level 1)

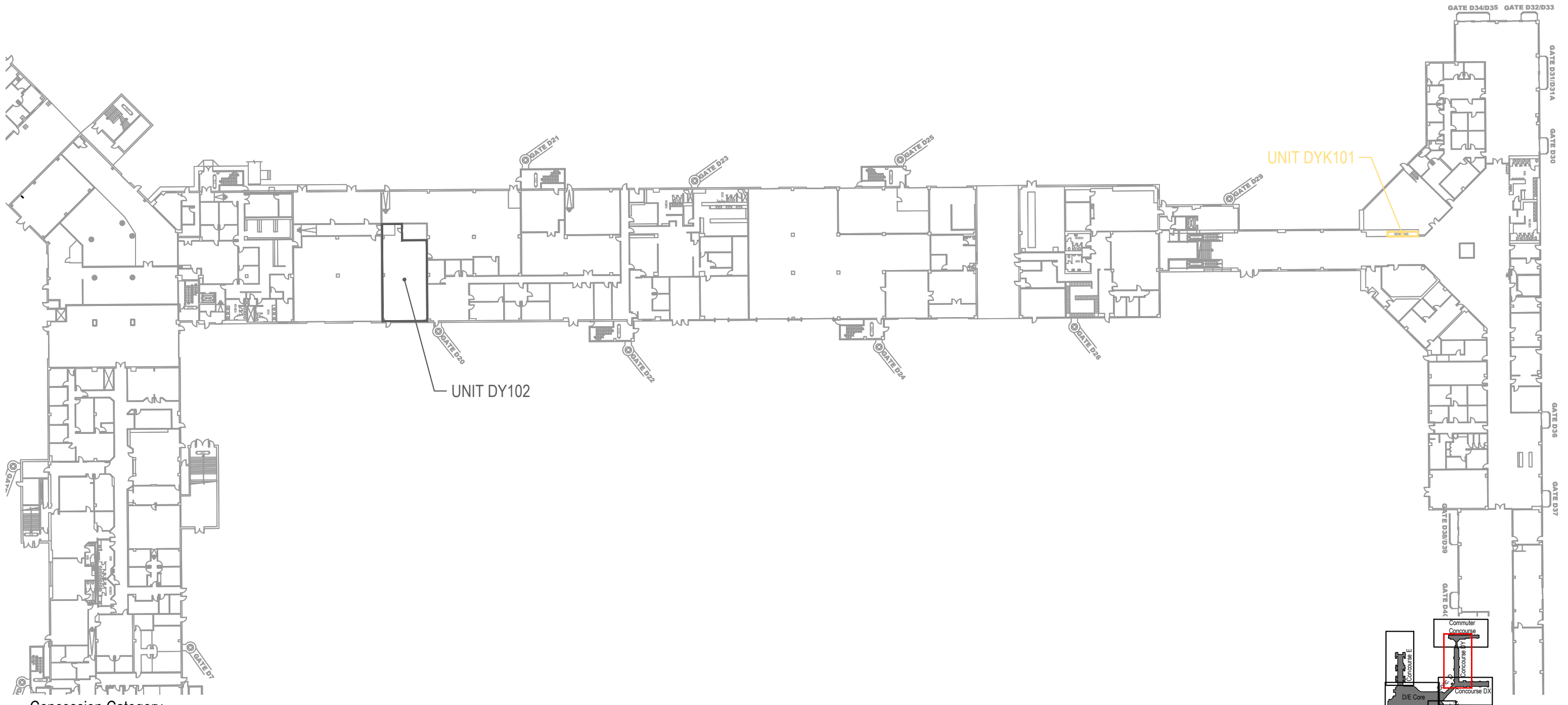

**Concession Category**

- |   |                    |   |                |
|---|--------------------|---|----------------|
|  | Food Service       |  | Services       |
|  | Convenience Retail |  | Support Space  |
|  | Specialty Retail   |  | MAA Controlled |
|  | Vending            |   |                |

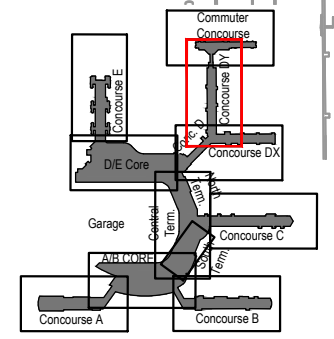

Key Plan: Airport



SCALE: 1/64" = 1'-0"



# Commuter Concourse D - Lower Level (Level 1)

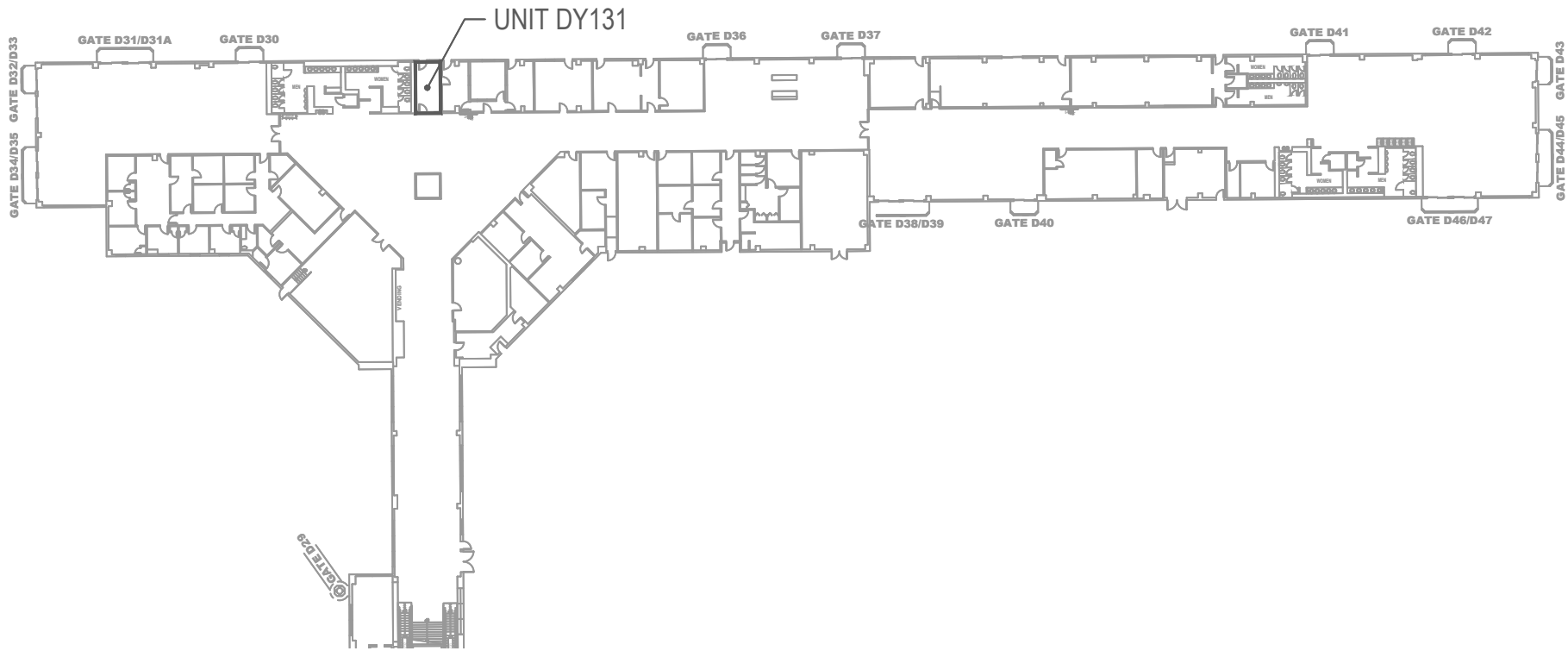

- Concession Category
- Food Service
  - Convenience Retail
  - Specialty Retail
  - Vending
  - Services
  - Support Space
  - MAA Controlled

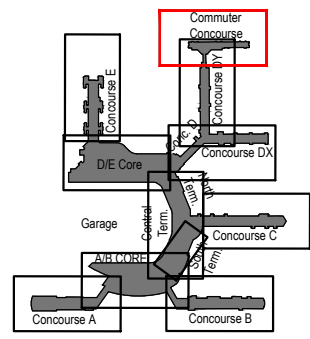
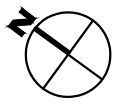

Key Plan: Airport

# D/E Core - Lower Level (Level 1)

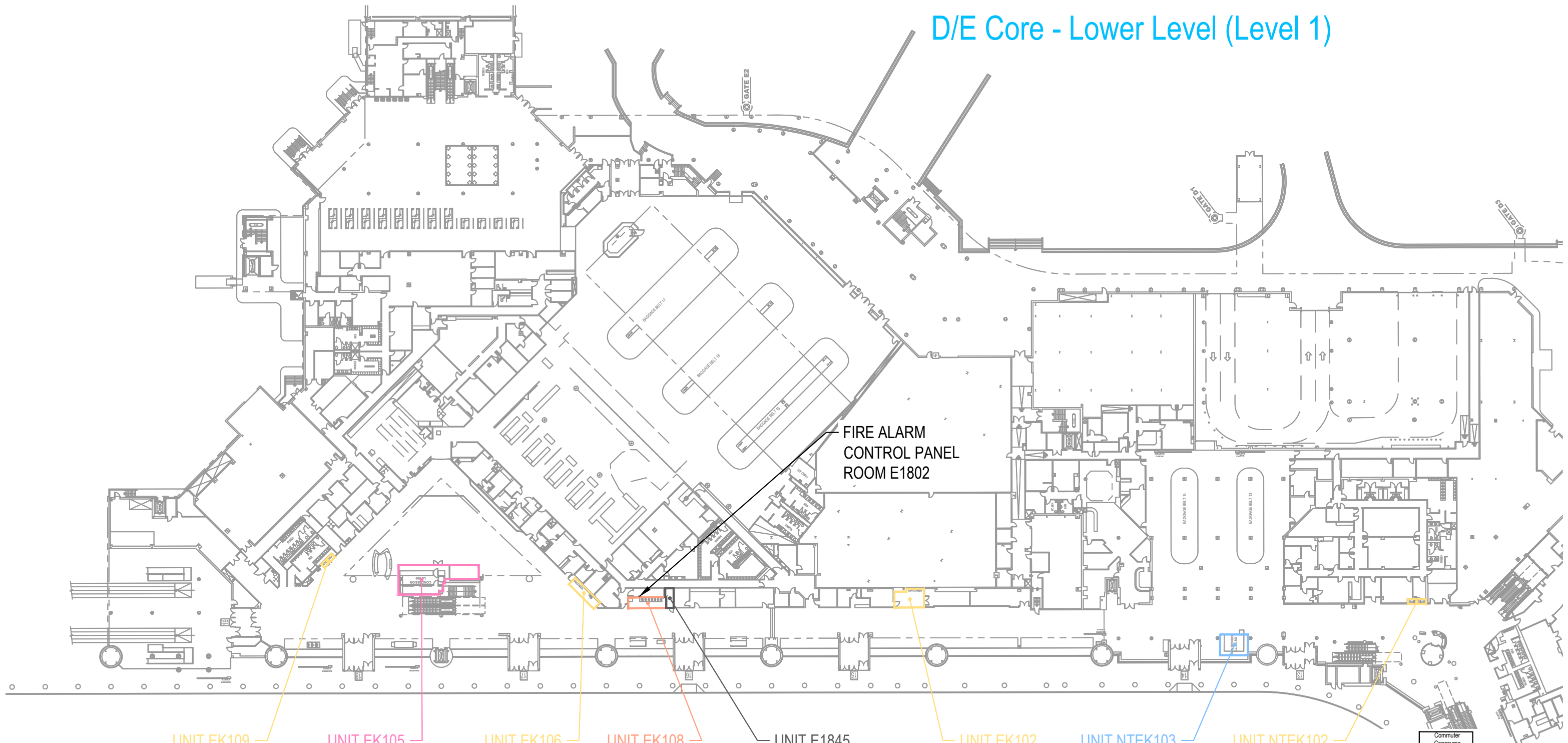

### Concession Category

- |  |  |
|--|--|
| <span style="border: 1px solid pink; display: inline-block; width: 15px; height: 10px;"></span> Food Service       | <span style="border: 1px solid orange; display: inline-block; width: 15px; height: 10px;"></span> Services       |
| <span style="border: 1px solid blue; display: inline-block; width: 15px; height: 10px;"></span> Convenience Retail | <span style="border: 1px solid black; display: inline-block; width: 15px; height: 10px;"></span> Support Space   |
| <span style="border: 1px solid green; display: inline-block; width: 15px; height: 10px;"></span> Specialty Retail  | <span style="border: 1px solid purple; display: inline-block; width: 15px; height: 10px;"></span> MAA Controlled |
| <span style="border: 1px solid yellow; display: inline-block; width: 15px; height: 10px;"></span> Vending          |  |

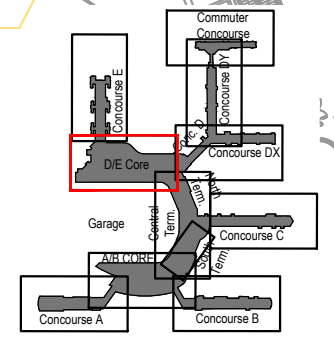

# Concourse E - Lower Level (Level 1)

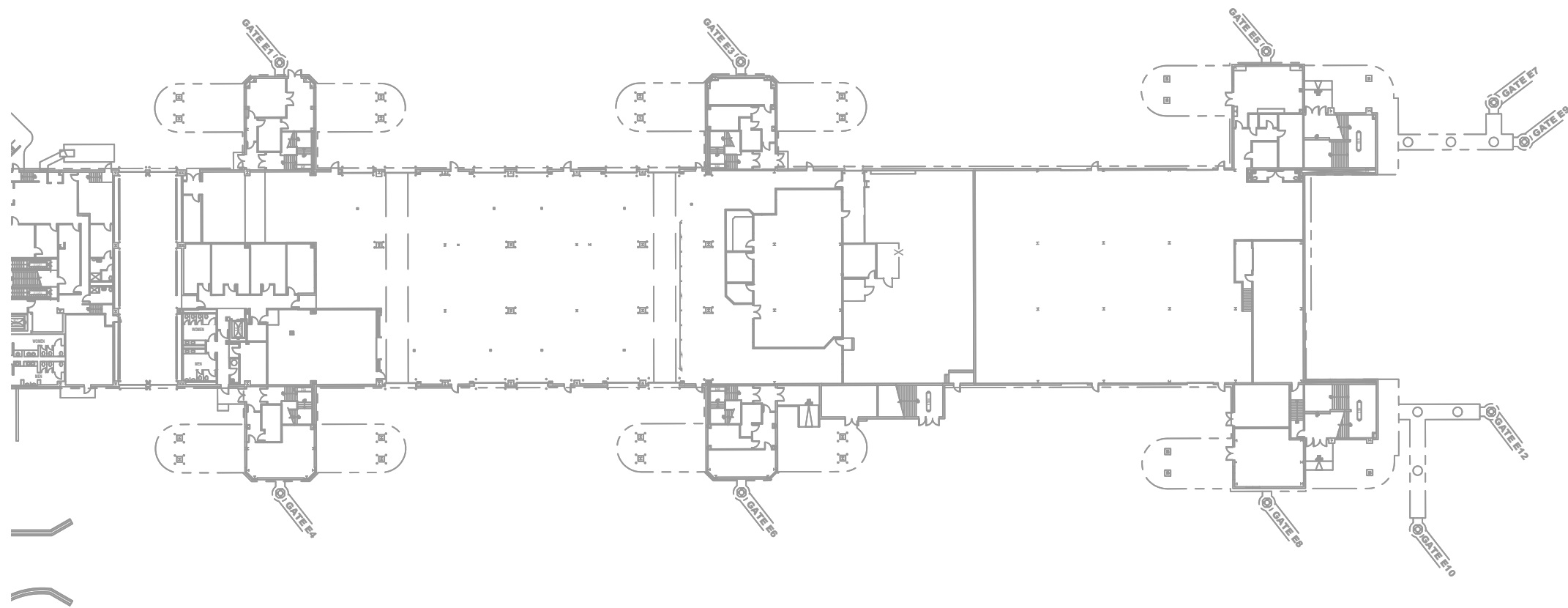

ITE E2

### Concession Category

- |   |                    |   |                |
|---|--------------------|---|----------------|
|  | Food Service       |  | Services       |
|  | Convenience Retail |  | Support Space  |
|  | Specialty Retail   |  | MAA Controlled |
|  | Vending            |   |                |

MAA / BWI - CONCESSION DEVELOPMENT REQUEST  
FOR PROPOSAL SUPPLEMENTAL UTILITIES DOCUMENT



SCALE: 1/64" = 1'-0"

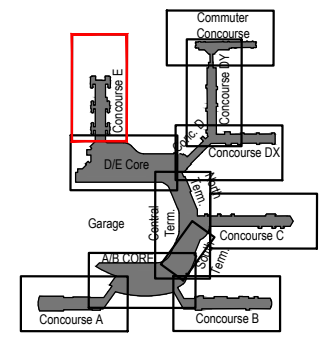

Key Plan: Airport

CONCOURSE E - LOWER LEVEL  
FIRE ALARM PLAN



# Concourse A - Upper Level (Level 2)

SPARE CAPACITY	
SENSORS	MODULES
76%	57%

= AREA SERVED BY FIRE ALARM CONTROL PANEL LOCATED IN ROOM A153

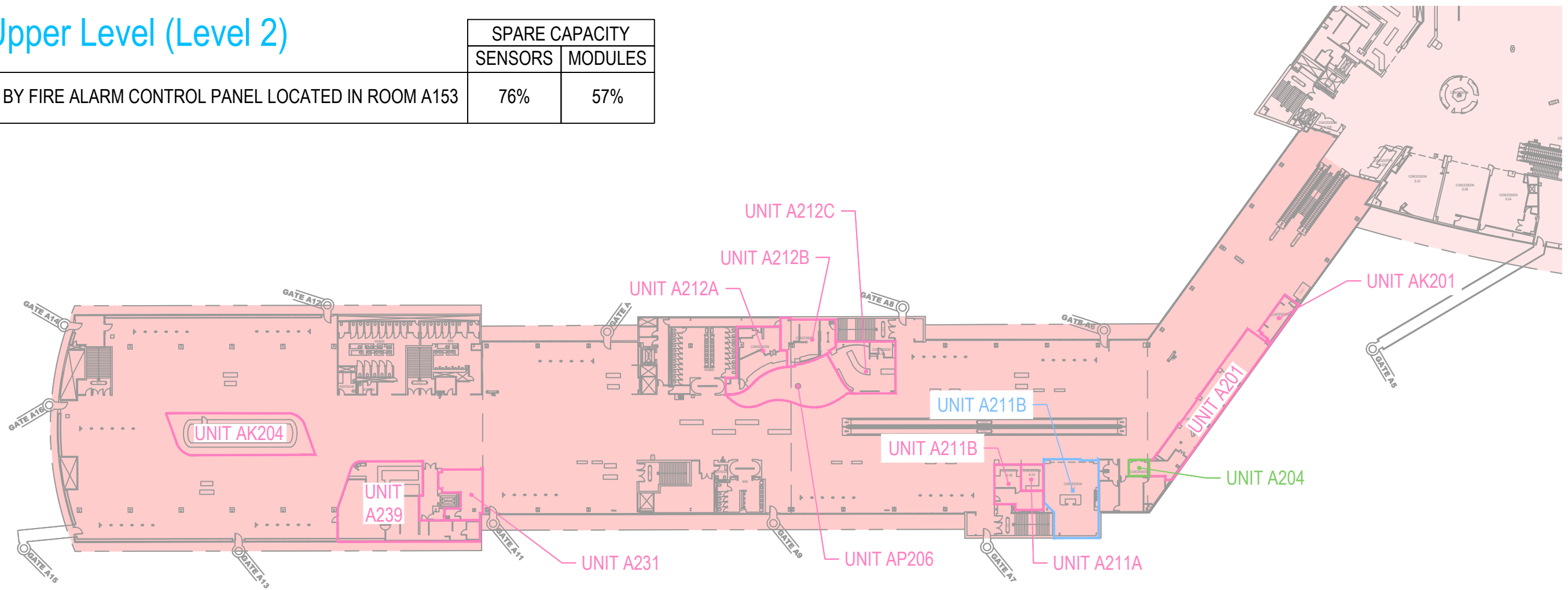

## NOTES:

1. REFER TO GROUND LEVEL DRAWING FOR FIRE ALARM CONTROL PANEL LOCATION.
2. REFER TO FIRE ALARM CONTROL PANEL SLC LOOP CAPACITY DRAWINGS FOR ADDITIONAL INFORMATION.

### Concession Category

- |   |   |
|---|---|
| <span style="display: inline-block; width: 15px; height: 10px; background-color: #f8d7da; border: 1px solid #f5c6cb; margin-right: 5px;"></span> Food Service       | <span style="display: inline-block; width: 15px; height: 10px; background-color: #fff3cd; border: 1px solid #ffee58; margin-right: 5px;"></span> Services       |
| <span style="display: inline-block; width: 15px; height: 10px; background-color: #d1ecf1; border: 1px solid #bee5eb; margin-right: 5px;"></span> Convenience Retail | <span style="display: inline-block; width: 15px; height: 10px; background-color: #e2e3e5; border: 1px solid #d6d8db; margin-right: 5px;"></span> Support Space  |
| <span style="display: inline-block; width: 15px; height: 10px; background-color: #d4edda; border: 1px solid #c3e6cb; margin-right: 5px;"></span> Specialty Retail   | <span style="display: inline-block; width: 15px; height: 10px; background-color: #e2e3e5; border: 1px solid #d6d8db; margin-right: 5px;"></span> MAA Controlled |
| <span style="display: inline-block; width: 15px; height: 10px; background-color: #fff3cd; border: 1px solid #ffee58; margin-right: 5px;"></span> Vending            |   |



SCALE: 1/64" = 1'-0"

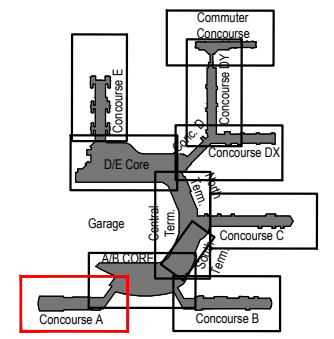

Key Plan: Airport

# A/B Core - Upper Level (Level 2)

SPARE CAPACITY	
SENSORS	MODULES
68%	25%
69%	22%

= AREA SERVED BY FIRE ALARM CONTROL PANEL LOCATED IN ROOM AT045  
 = AREA SERVED BY FIRE ALARM CONTROL PANEL LOCATED IN ROOM B105

### NOTES:

1. REFER TO GROUND LEVEL DRAWING FOR FIRE ALARM CONTROL PANEL LOCATION.
2. REFER TO FIRE ALARM CONTROL PANEL SLC LOOP CAPACITY DRAWINGS FOR ADDITIONAL INFORMATION.

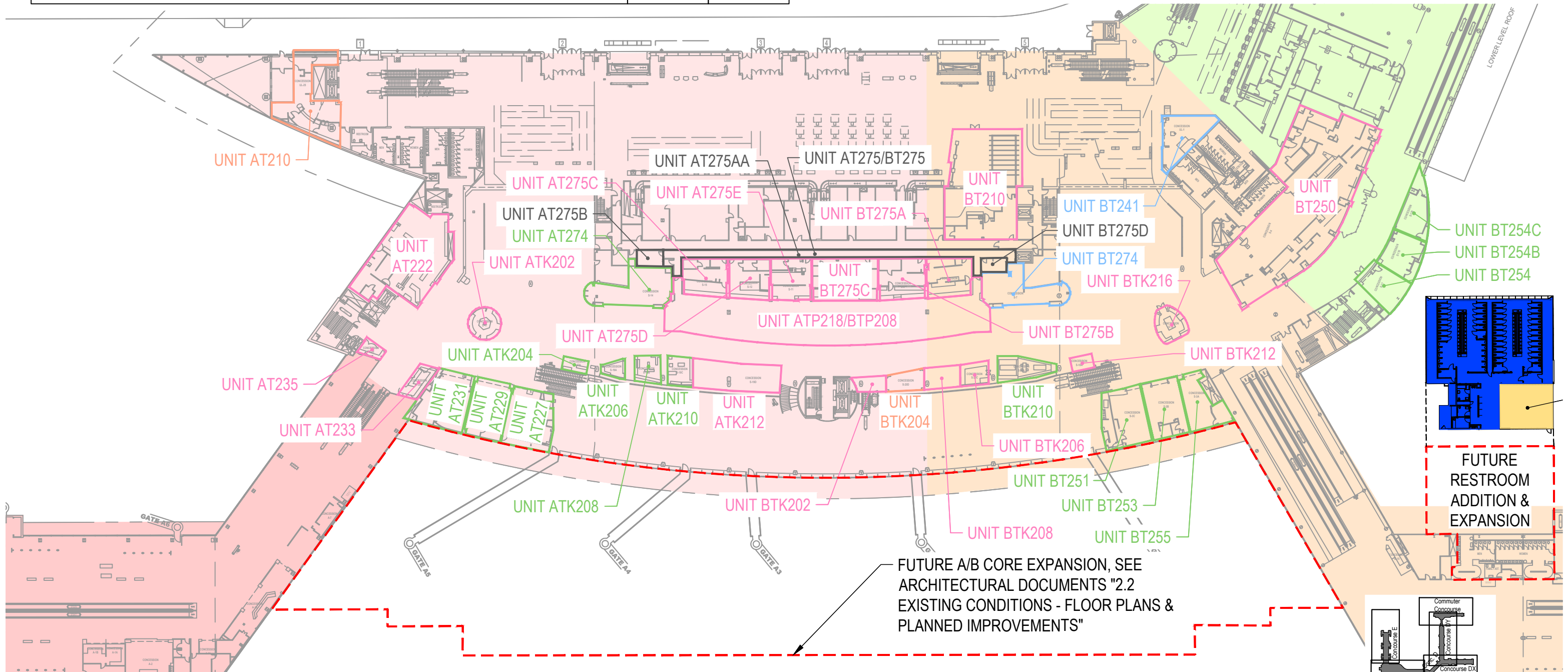

**Concession Category**

<span style="display: inline-block; width: 15px; height: 10px; background-color: #fff3cd; border: 1px solid #ffee58;"></span> Food Service	<span style="display: inline-block; width: 15px; height: 10px; background-color: #fff3cd; border: 1px solid #ffee58;"></span> Services
<span style="display: inline-block; width: 15px; height: 10px; background-color: #d1ecf1; border: 1px solid #bee5eb;"></span> Convenience Retail	<span style="display: inline-block; width: 15px; height: 10px; background-color: #d1ecf1; border: 1px solid #bee5eb;"></span> Support Space
<span style="display: inline-block; width: 15px; height: 10px; background-color: #d4edda; border: 1px solid #c3e6cb;"></span> Specialty Retail	<span style="display: inline-block; width: 15px; height: 10px; background-color: #d4edda; border: 1px solid #c3e6cb;"></span> MAA Controlled
<span style="display: inline-block; width: 15px; height: 10px; background-color: #fff3cd; border: 1px solid #ffee58;"></span> Vending	

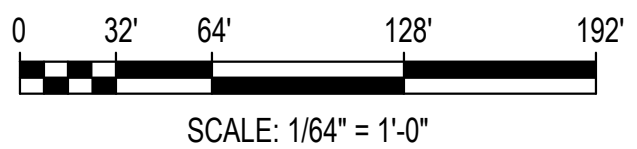

# Concourse B - Upper Level (Level 2)

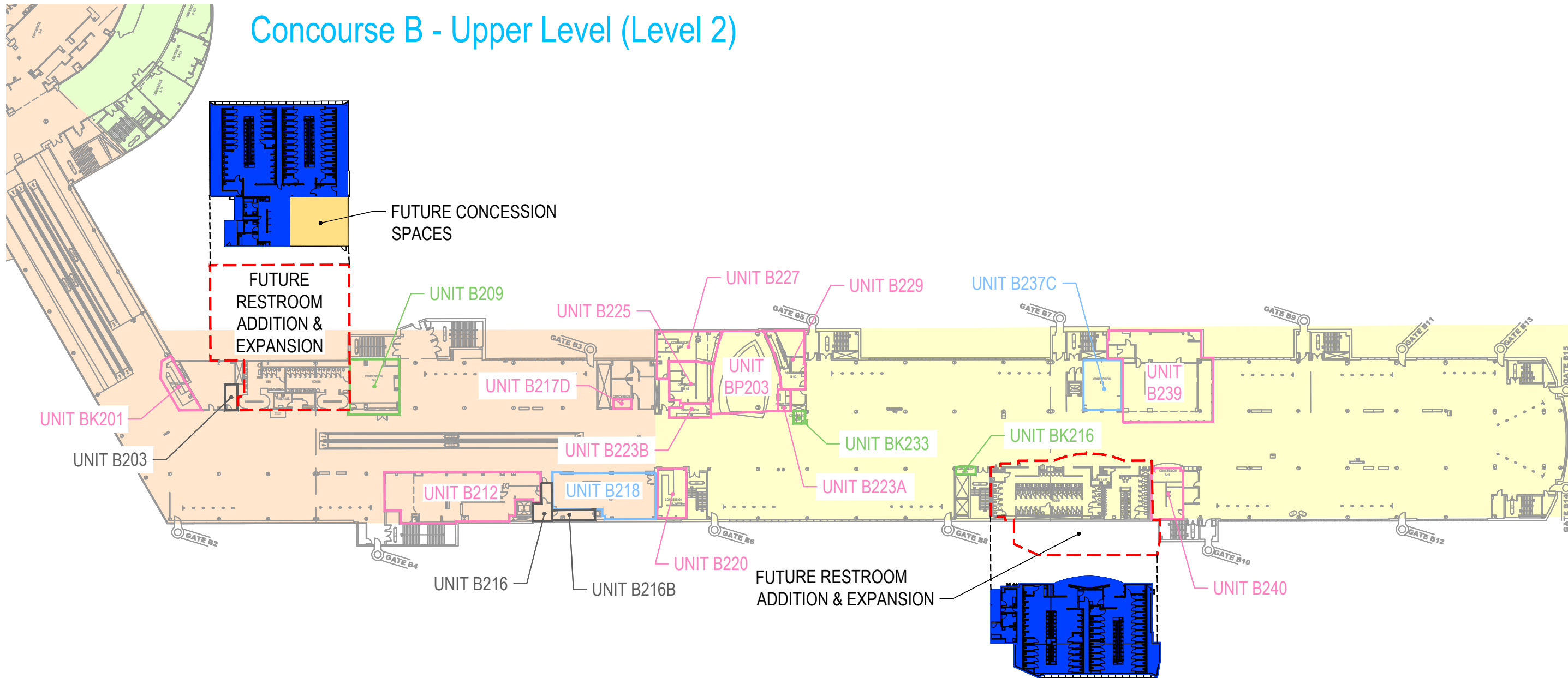

	SPARE CAPACITY	
	SENSORS	MODULES
= AREA SERVED BY FIRE ALARM CONTROL PANEL LOCATED IN ROOM B145	83%	65%
= AREA SERVED BY FIRE ALARM CONTROL PANEL LOCATED IN ROOM B105	69%	22%

### Concession Category

- Food Service
- Convenience Retail
- Specialty Retail
- Vending
- Services
- Support Space
- MAA Controlled

### NOTES:

1. REFER TO GROUND LEVEL DRAWING FOR FIRE ALARM CONTROL PANEL LOCATION.
2. REFER TO FIRE ALARM CONTROL PANEL SLC LOOP CAPACITY DRAWINGS FOR ADDITIONAL INFORMATION.

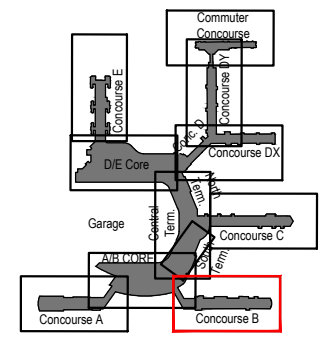

Key Plan: Airport



SCALE: 1/64" = 1'-0"





# Terminal South, Center, North - Upper Level (Level 2)

- = AREA SERVED BY FIRE ALARM CONTROL PANEL LOCATED IN ROOM ST105
- = AREA SERVED BY FIRE ALARM CONTROL PANEL LOCATED IN ROOM CTS1LL
- = AREA SERVED BY FIRE ALARM CONTROL PANEL LOCATED IN ROOM NT109
- = AREA SERVED BY FIRE ALARM CONTROL PANEL LOCATED IN ROOM NTE253A

SPARE CAPACITY	
SENSORS	MODULES
68%	40%
32%	58%
67%	45%
66%	60%

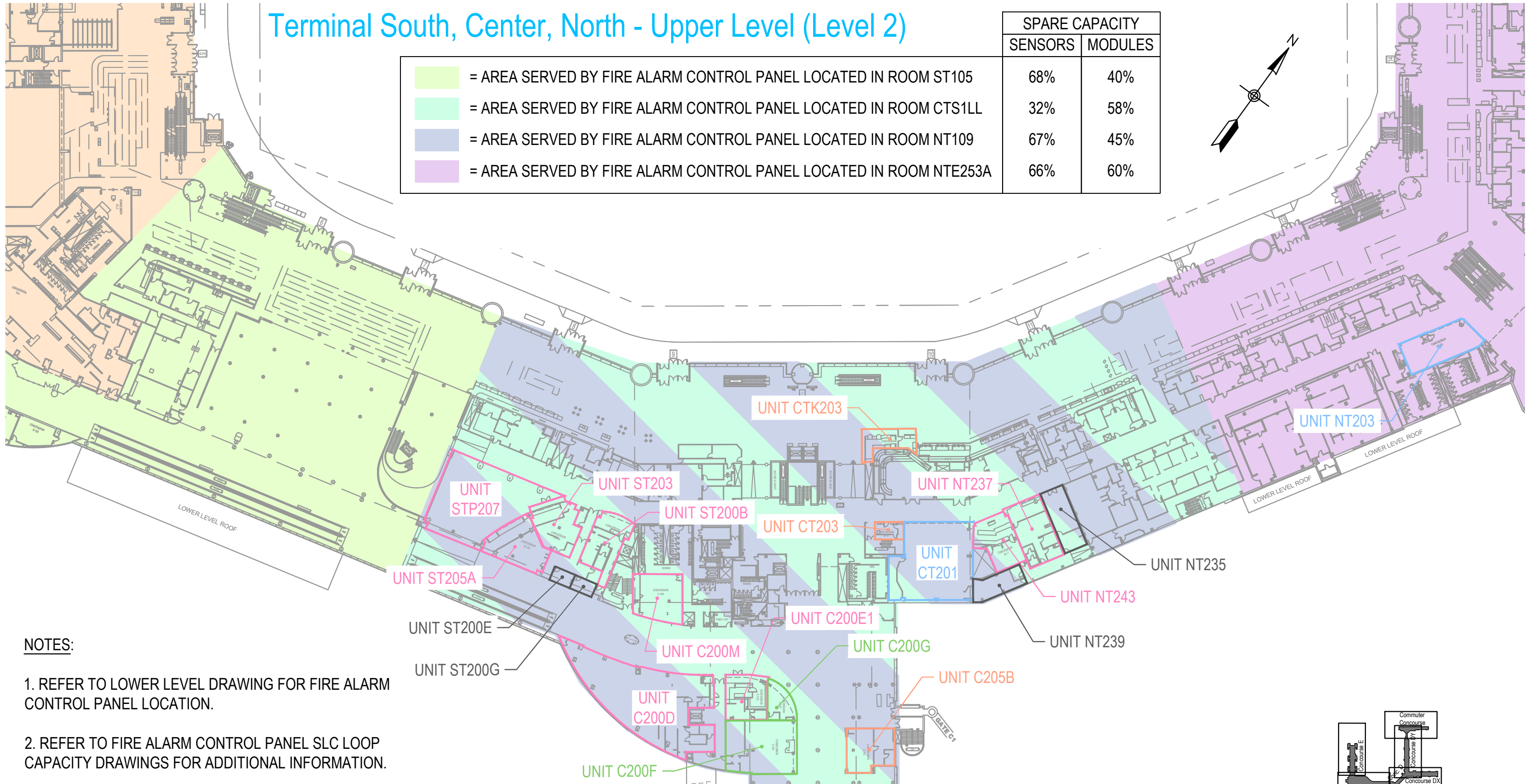

- NOTES:**
- REFER TO LOWER LEVEL DRAWING FOR FIRE ALARM CONTROL PANEL LOCATION.
  - REFER TO FIRE ALARM CONTROL PANEL SLC LOOP CAPACITY DRAWINGS FOR ADDITIONAL INFORMATION.

**Concession Category**

<span style="display: inline-block; width: 15px; height: 10px; border: 1px solid pink; margin-right: 5px;"></span> Food Service	<span style="display: inline-block; width: 15px; height: 10px; border: 1px solid orange; margin-right: 5px;"></span> Services
<span style="display: inline-block; width: 15px; height: 10px; border: 1px solid blue; margin-right: 5px;"></span> Convenience Retail	<span style="display: inline-block; width: 15px; height: 10px; border: 1px solid black; margin-right: 5px;"></span> Support Space
<span style="display: inline-block; width: 15px; height: 10px; border: 1px solid green; margin-right: 5px;"></span> Specialty Retail	<span style="display: inline-block; width: 15px; height: 10px; border: 1px solid purple; margin-right: 5px;"></span> MAA Controlled
<span style="display: inline-block; width: 15px; height: 10px; border: 1px solid yellow; margin-right: 5px;"></span> Vending	

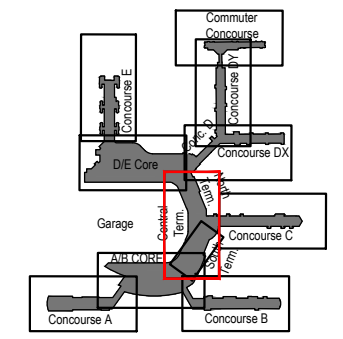
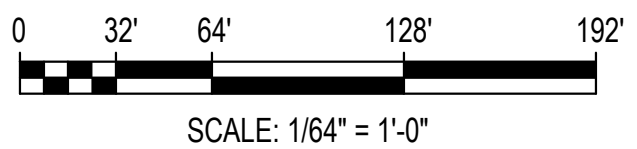



# Concourse C - Upper Level (Level 2)

	SPARE CAPACITY	
	SENSORS	MODULES
AREA SERVED BY FIRE ALARM CONTROL PANEL LOCATED IN ROOM CTS1LL	32%	58%
AREA SERVED BY FIRE ALARM CONTROL PANEL LOCATED IN ROOM NT109	67%	45%
AREA SERVED BY FIRE ALARM CONTROL PANEL LOCATED IN ROOM C141	66%	42%

- = AREA SERVED BY FIRE ALARM CONTROL PANEL LOCATED IN ROOM CTS1LL
- = AREA SERVED BY FIRE ALARM CONTROL PANEL LOCATED IN ROOM NT109
- = AREA SERVED BY FIRE ALARM CONTROL PANEL LOCATED IN ROOM C141

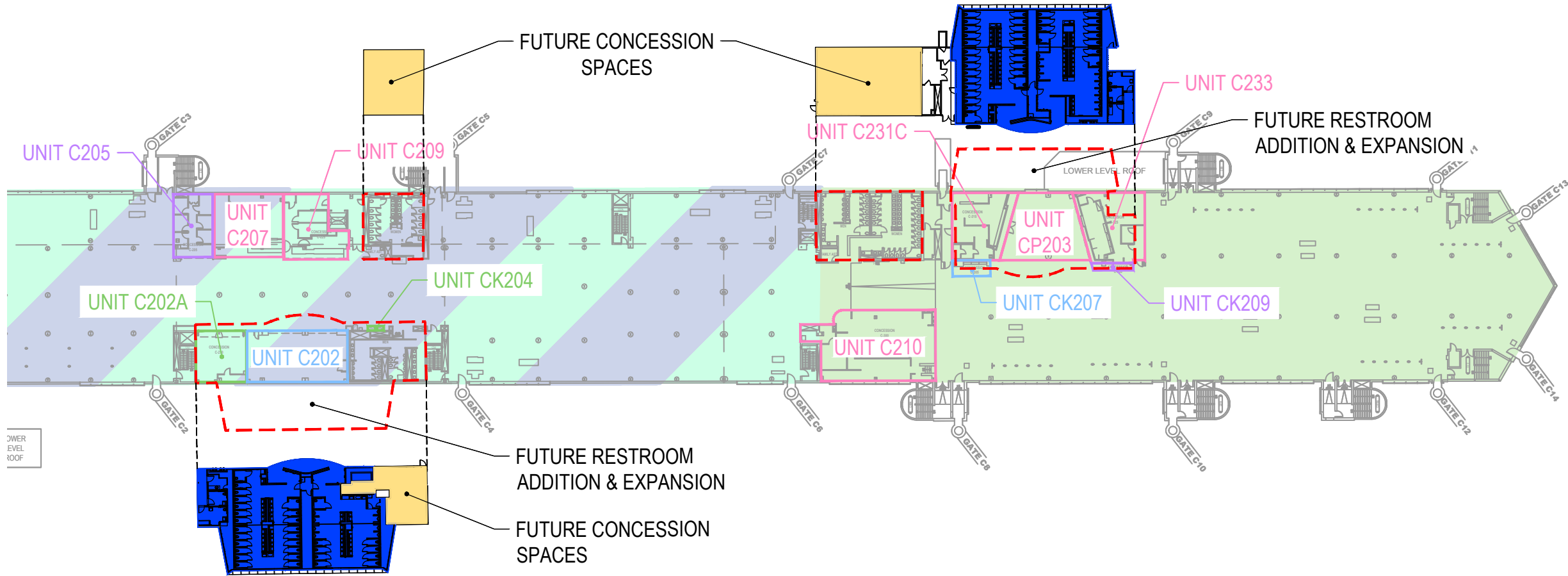

**NOTES:**

1. REFER TO LOWER LEVEL DRAWING FOR FIRE ALARM CONTROL PANEL LOCATION.
2. REFER TO FIRE ALARM CONTROL PANEL SLC LOOP CAPACITY DRAWINGS FOR ADDITIONAL INFORMATION.

**Concession Category**

- Food Service
- Services
- Convenience Retail
- Support Space
- Specialty Retail
- MAA Controlled
- Vending



SCALE: 1/64" = 1'-0"

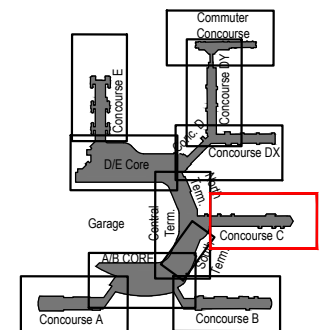

Key Plan: Airport

# Concourse D, DX - Upper Level (Level 2)

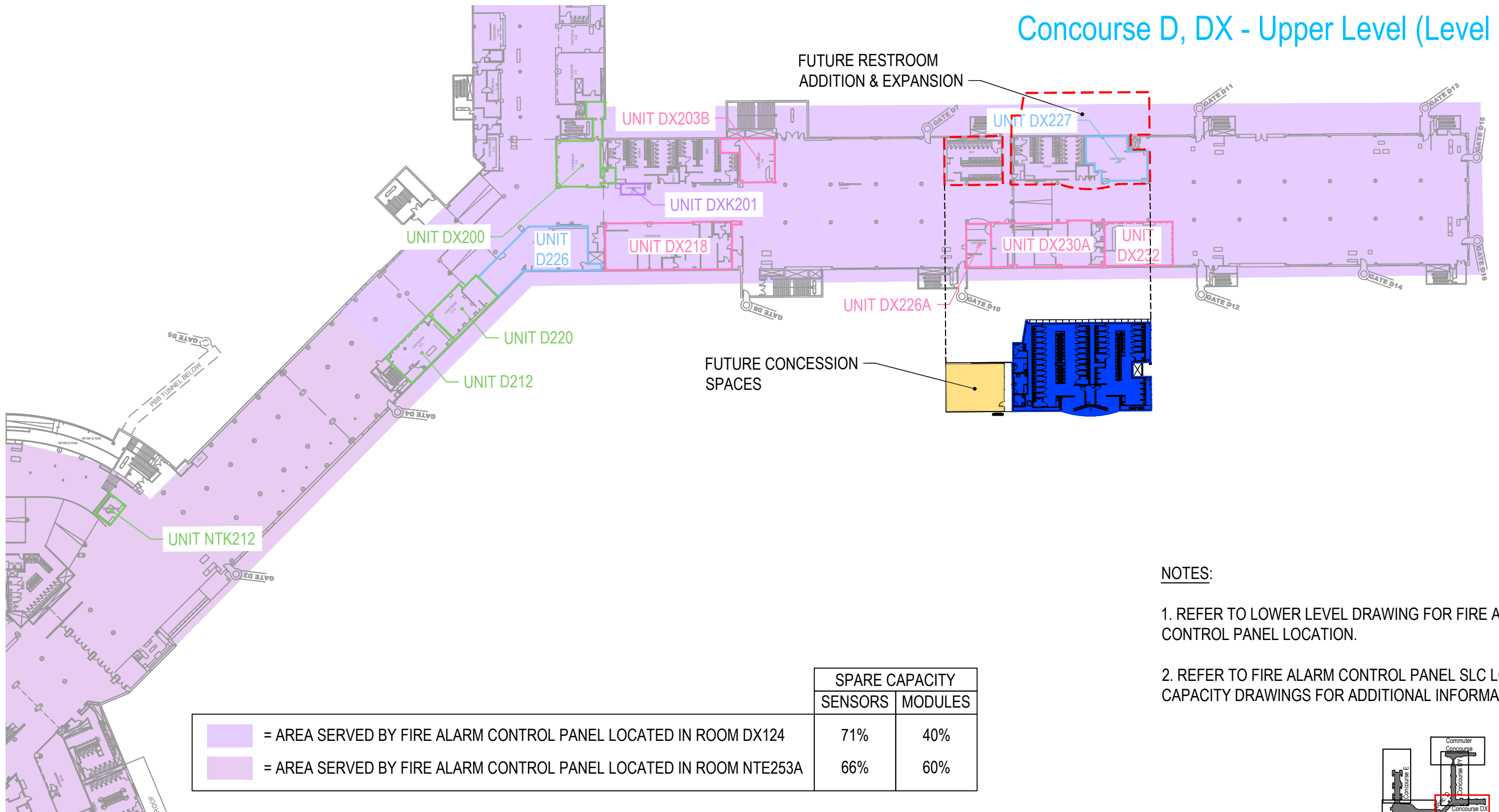

FUTURE RESTROOM  
ADDITION & EXPANSION

FUTURE CONCESSION  
SPACES

**NOTES:**

1. REFER TO LOWER LEVEL DRAWING FOR FIRE ALARM CONTROL PANEL LOCATION.
2. REFER TO FIRE ALARM CONTROL PANEL SLC LOOP CAPACITY DRAWINGS FOR ADDITIONAL INFORMATION.

= AREA SERVED BY FIRE ALARM CONTROL PANEL LOCATED IN ROOM DX124  
 = AREA SERVED BY FIRE ALARM CONTROL PANEL LOCATED IN ROOM NTE253A

SPARE CAPACITY	
SENSORS	MODULES
71%	40%
66%	60%

**Concession Category**

- Food Service
- Convenience Retail
- Specialty Retail
- Vending
- Services
- Support Space
- MAA Controlled

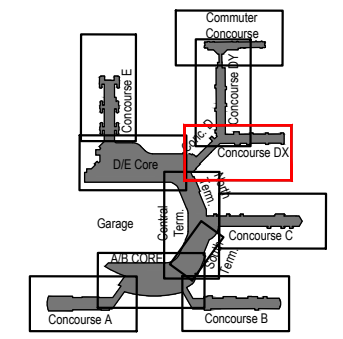
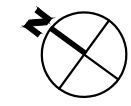
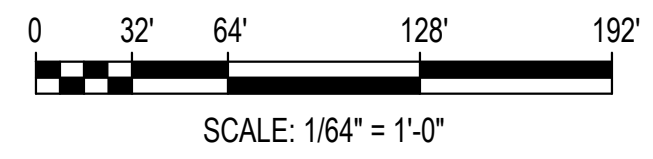

Key Plan: Airport

# Concourse DY - Upper Level (Level 2)

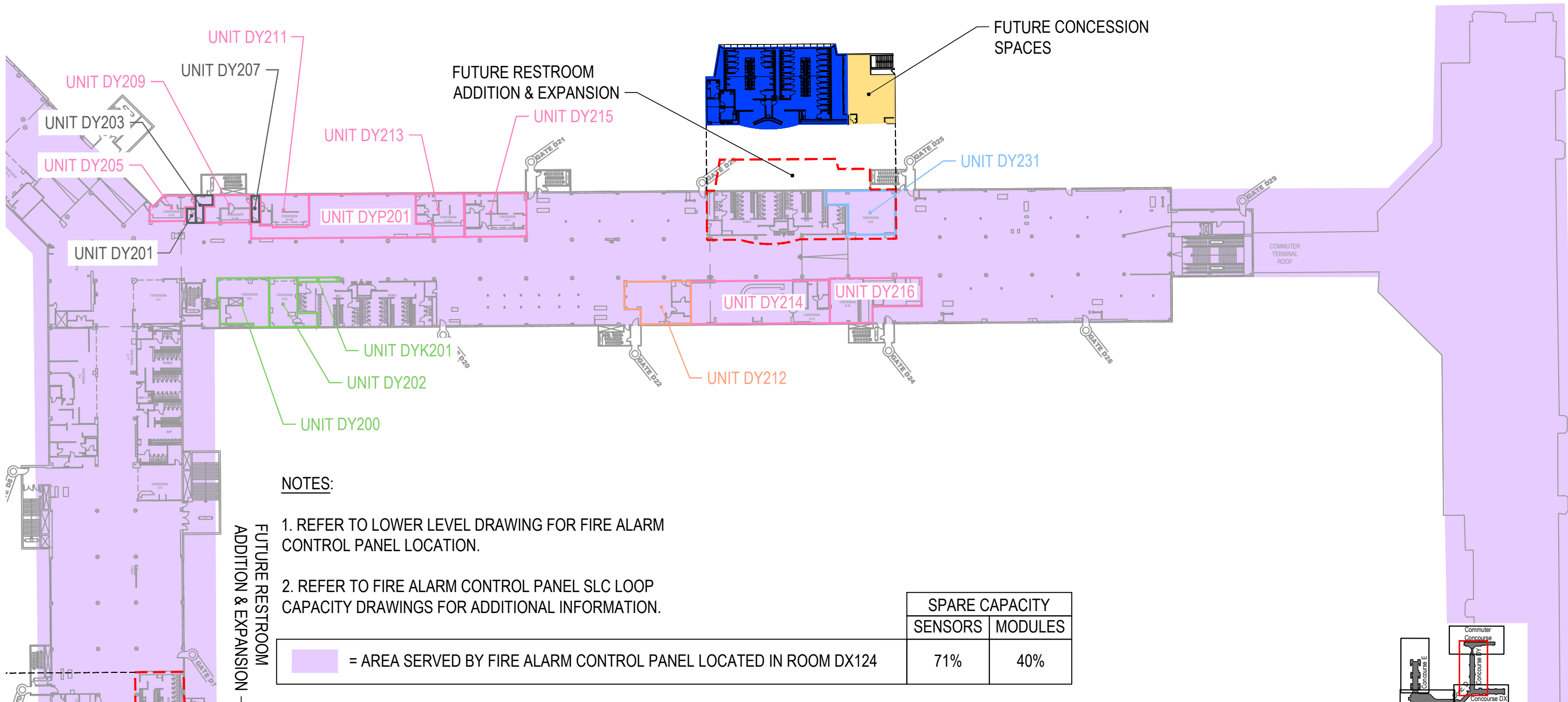

**NOTES:**

1. REFER TO LOWER LEVEL DRAWING FOR FIRE ALARM CONTROL PANEL LOCATION.
2. REFER TO FIRE ALARM CONTROL PANEL SLC LOOP CAPACITY DRAWINGS FOR ADDITIONAL INFORMATION.

FUTURE RESTROOM ADDITION & EXPANSION

= AREA SERVED BY FIRE ALARM CONTROL PANEL LOCATED IN ROOM DX124

SPARE CAPACITY	
SENSORS	MODULES
71%	40%

**Concession Category**

- Food Service
- Convenience Retail
- Specialty Retail
- Vending
- Services
- Support Space
- MAA Controlled

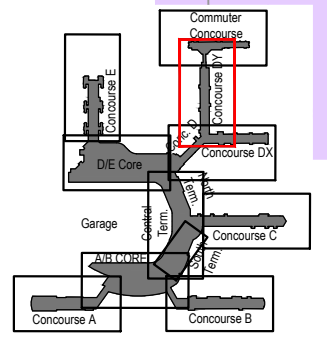
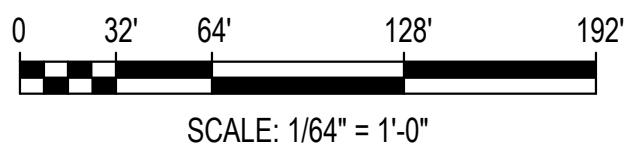

Key Plan: Airport

# D/E Core - Upper Level (Level 2)

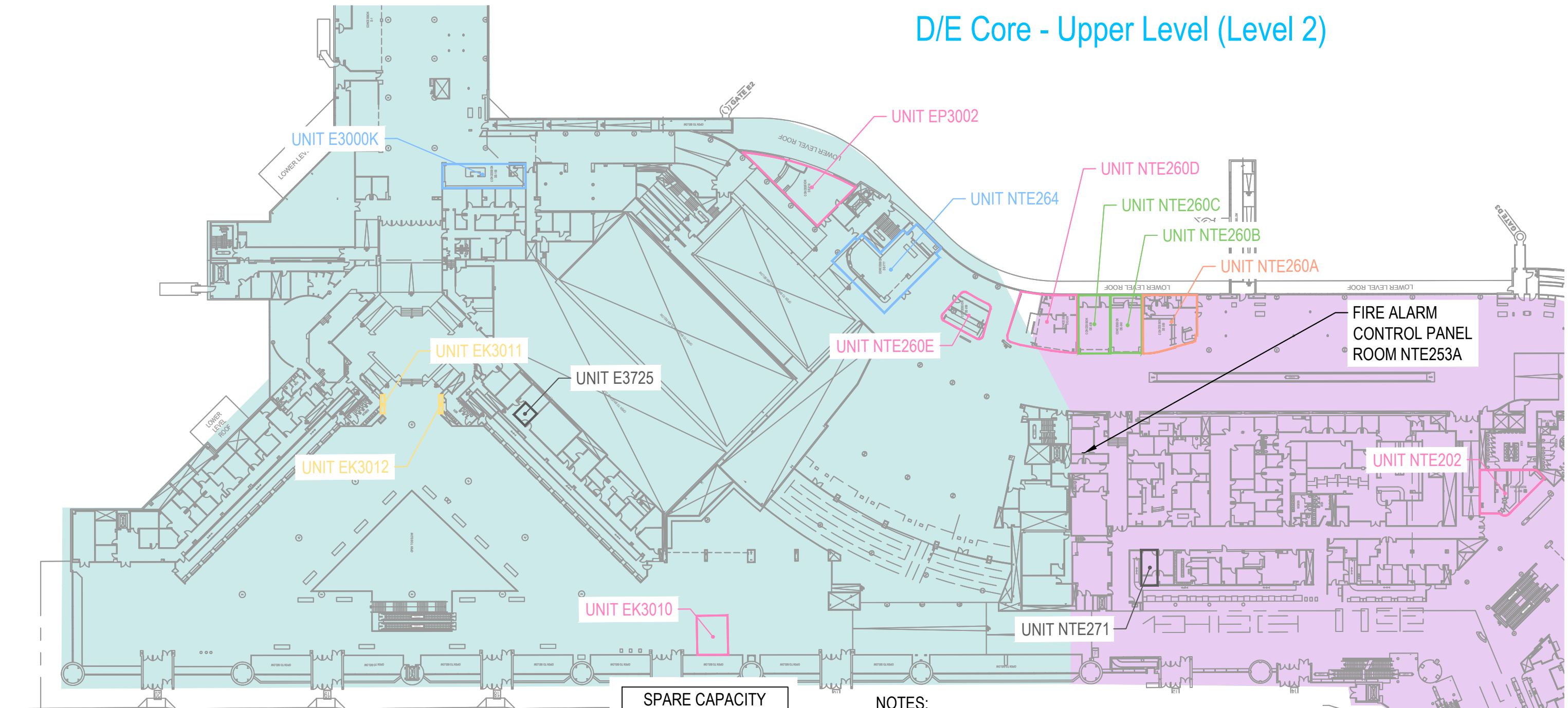

= AREA SERVED BY FIRE ALARM CONTROL PANEL LOCATED IN ROOM NTE253A  
 = AREA SERVED BY FIRE ALARM CONTROL PANEL LOCATED IN ROOM E1802

SPARE CAPACITY	
SENSORS	MODULES
66%	60%
79%	58%

- NOTES:**
- REFER TO LOWER LEVEL DRAWING FOR FIRE ALARM CONTROL PANEL LOCATION.
  - REFER TO FIRE ALARM CONTROL PANEL SLC LOOP CAPACITY DRAWINGS FOR ADDITIONAL INFORMATION.

**Concession Category**

<span style="display: inline-block; width: 15px; height: 15px; background-color: #ffcc99; border: 1px solid black; margin-right: 5px;"></span> Food Service	<span style="display: inline-block; width: 15px; height: 15px; background-color: #ffcc99; border: 1px solid black; margin-right: 5px;"></span> Services
<span style="display: inline-block; width: 15px; height: 15px; background-color: #add8e6; border: 1px solid black; margin-right: 5px;"></span> Convenience Retail	<span style="display: inline-block; width: 15px; height: 15px; background-color: #add8e6; border: 1px solid black; margin-right: 5px;"></span> Support Space
<span style="display: inline-block; width: 15px; height: 15px; background-color: #90ee90; border: 1px solid black; margin-right: 5px;"></span> Specialty Retail	<span style="display: inline-block; width: 15px; height: 15px; background-color: #90ee90; border: 1px solid black; margin-right: 5px;"></span> MAA Controlled
<span style="display: inline-block; width: 15px; height: 15px; background-color: #ffff00; border: 1px solid black; margin-right: 5px;"></span> Vending	

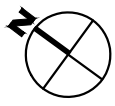
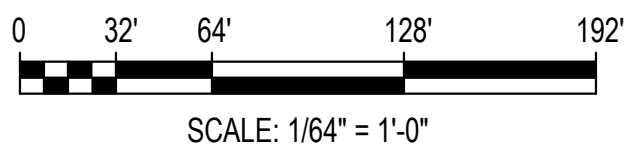
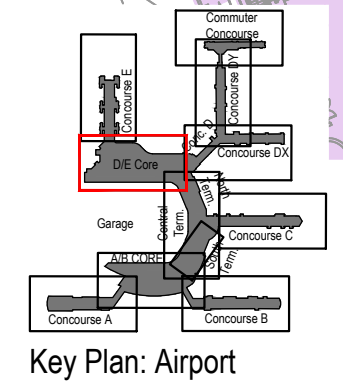



# Concourse E - Upper Level (Level 2)

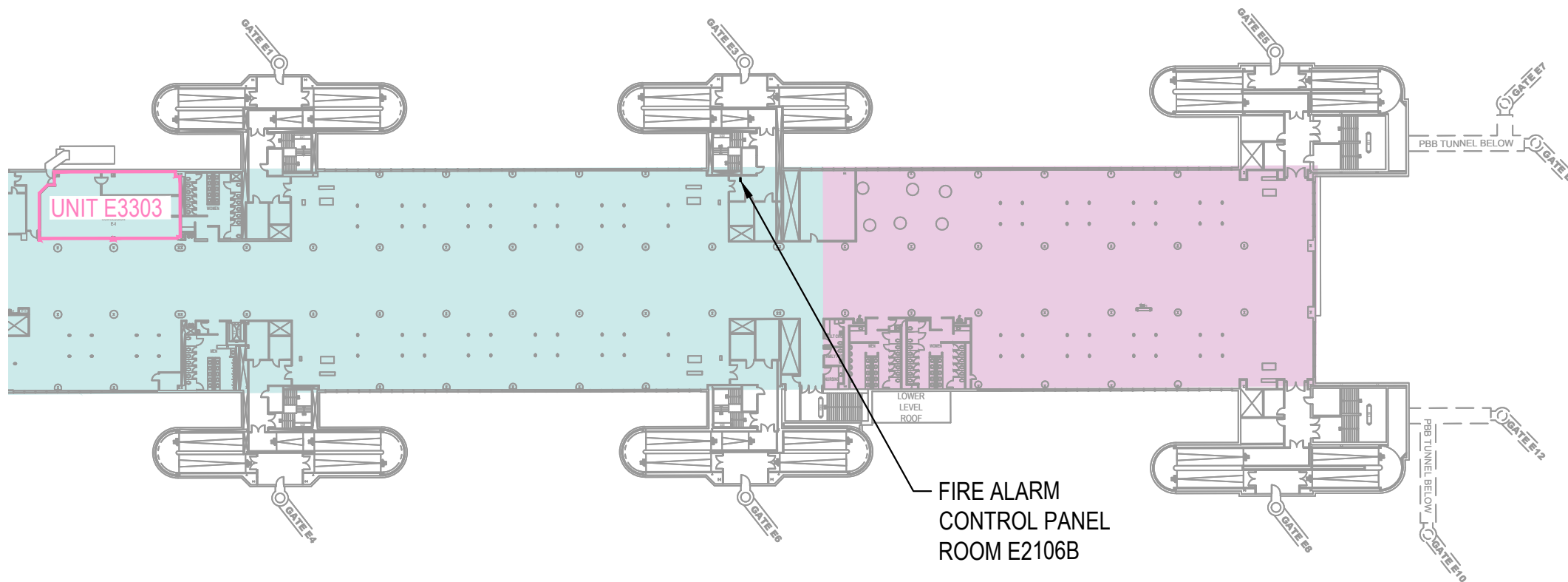

	SPARE CAPACITY	
	SENSORS	MODULES
= AREA SERVED BY FIRE ALARM CONTROL PANEL LOCATED IN ROOM E2106A	81%	61%
= AREA SERVED BY FIRE ALARM CONTROL PANEL LOCATED IN ROOM E1802	79%	58%

### Concession Category

- Food Service
- Convenience Retail
- Specialty Retail
- Vending
- Services
- Support Space
- MAA Controlled

### NOTES:

1. REFER TO LOWER LEVEL DRAWING FOR FIRE ALARM CONTROL PANEL LOCATION.
2. REFER TO FIRE ALARM CONTROL PANEL SLC LOOP CAPACITY DRAWINGS FOR ADDITIONAL INFORMATION.



SCALE: 1/64" = 1'-0"

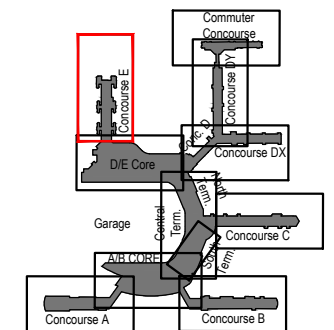

Key Plan: Airport

# Terminal Observation Gallery - Upper Level Mezzanine

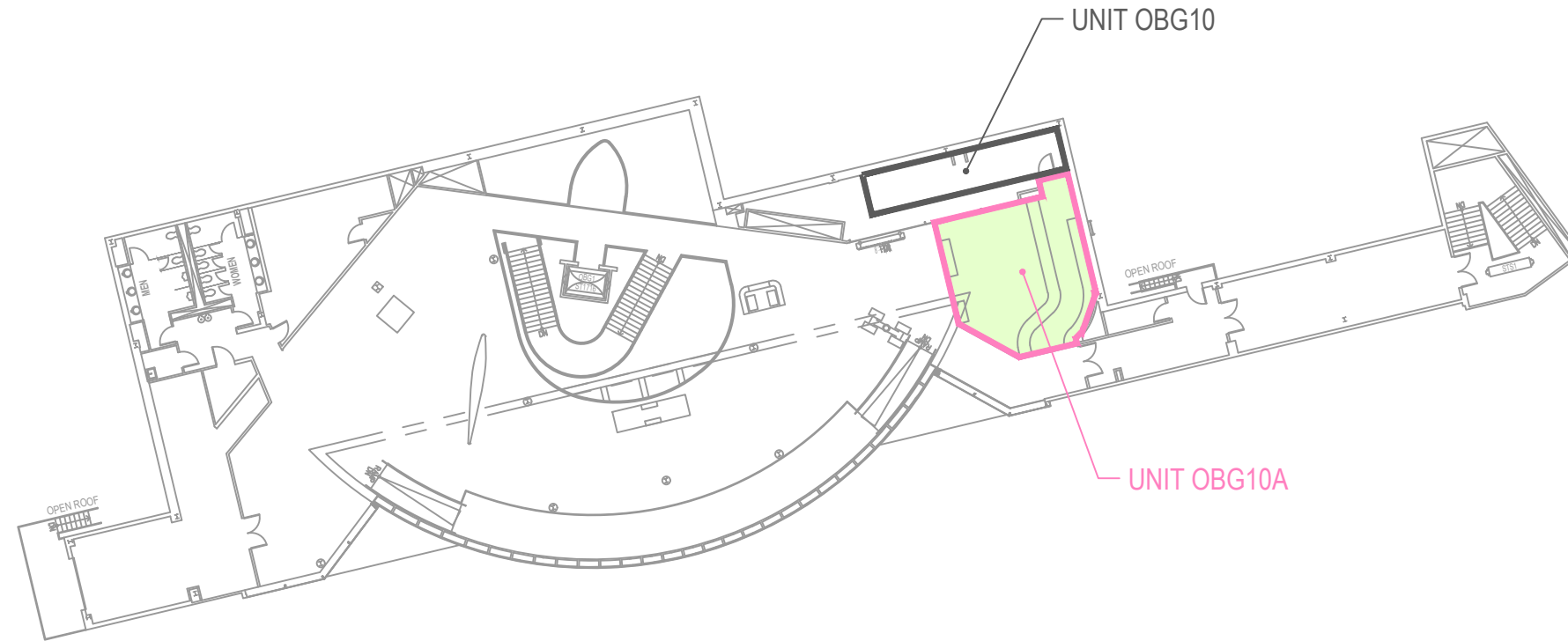

**NOTES:**

1. REFER TO LOWER LEVEL DRAWING FOR FIRE ALARM CONTROL PANEL LOCATION.
2. REFER TO FIRE ALARM CONTROL PANEL SLC LOOP CAPACITY DRAWINGS FOR ADDITIONAL INFORMATION.

SPARE CAPACITY	
SENSORS	MODULES
68%	40%

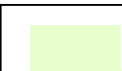
 = AREA SERVED BY FIRE ALARM CONTROL PANEL LOCATED IN ROOM ST105

**Concession Category**

-  Food Service
-  Convenience Retail
-  Specialty Retail
-  Vending
-  Services
-  Support Space
-  MAA Controlled

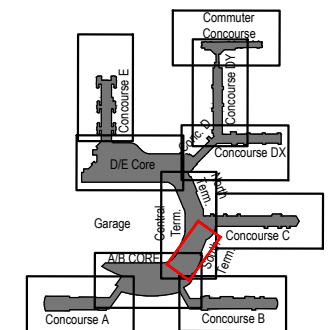

Key Plan: Airport



SCALE: 1/32" = 1'-0"



<i>Pier A FAP (XLS3000) Pier A \ Elect Rm-A153</i>				
<i>SLC Loop</i>	<i>Sensors in Use</i>	<i>Sensor addresses available</i>	<i>Modules</i>	<i>Modules Available</i>
1	41	118	90	69
2	24	135	91	68
3	42	117	53	106
4	37	122	71	88
5	67	92	79	80
6	24	135	38	121
7	52	107	87	72
8	24	135	38	121
9				
311		961	547	725
		76%		57%

<i>Terminal AB FAP (XLS3000) Term A-B \ Pier A - Fire Cmnd-AT045</i>				
<i>SLC Loop</i>	<i>Sensors in Use</i>	<i>Sensor addresses available</i>	<i>Modules</i>	<i>Modules Available</i>
1	41	118	90	69
2	24	135	91	68
3	42	117	53	106
4	37	122	71	88
5	67	92	79	80
6	24	135	38	121
7	52	107	87	72
8	24	135	38	121
9				
311		961	547	725
		68%		25%

<i>Pier B FAP (XLS1000) Pier B Lwr Lvl Electric Rm-B105</i>				
<i>SLC Loop</i>	<i>Sensors in Use</i>	<i>Sensor addresses available</i>	<i>Modules</i>	<i>Modules Available</i>
1	29	70	77	22
2	32	67	78	21
3				
4				
5				
6				
7				
8				
9				
61		137	155	43
		69%		22%

<i>Pier Bx FAP (XLS1000) Pier Bx Lwr Lvl Fire Cmnd Rm-B145</i>				
<i>SLC Loop</i>	<i>Sensors in Use</i>	<i>Sensor addresses available</i>	<i>Modules</i>	<i>Modules Available</i>
1	21	78	8	91
2	9	90	46	53
3	20	79	31	68
4	9	90	26	73
5	11	88	30	69
6	11	88	35	64
7	52	47	87	12
8	2	97	18	81
9				
135		657	281	511
		83%		65%

<i>South Terminal FAP (XLS1000) South Terminal - Fire Cmnd Rm-ST105</i>				
<i>SLC Loop</i>	<i>Sensors in Use</i>	<i>Sensor addresses available</i>	<i>Modules</i>	<i>Modules Available</i>
1	26	73	56	43
2	30	69	64	35
3				
4				
5	41	58	55	44
6				
7	43	56	81	18
8	20	79	41	58
9				
<hr/>				
160				
335				
297				
198				
68%				
40%				

<i>Pier C FAP (XLS1000) Pier C Lwr Lvl Fire - Mech Rm-C141 C9</i>				
<i>SLC Loop</i>	<i>Sensors in Use</i>	<i>Sensor addresses available</i>	<i>Modules</i>	<i>Modules Available</i>
1	62	37	81	18
2	58	41	68	31
3	36	63	52	47
4	12	87	34	65
5	30	69	57	42
6	14	85	50	49
7	26	73	58	41
8				
9				
<hr/>				
238				
455				
400				
293				
66%				
42%				

<i>FAA Twr FAP (XLS1000) FAA Control Tower Stair CTS1-LL</i>				
<i>SLC Loop</i>	<i>Sensors in Use</i>	<i>Sensor addresses available</i>	<i>Modules</i>	<i>Modules Available</i>
1	67	32	42	57
2				
3				
4				
5				
6				
7				
8				
9				
<hr/>				
67				
32				
42				
57				
32%				
58%				

<i>MAA\OPS FAP (XLS1000) MAA-OPS Lvl 3 Elect Rm-333</i>				
<i>SLC Loop</i>	<i>Sensors in Use</i>	<i>Sensor addresses available</i>	<i>Modules</i>	<i>Modules Available</i>
1				
2	10	89	14	85
3	11	88	7	92
4				
5				
6				
7				
8				
9				
<hr/>				
21				
177				
21				
177				
89%				
89%				



<i>North Terminal FAP (XLS1000) North Term Lwr Lvl Telephone Rm-NT109</i>				
<i>SLC Loop</i>	<i>Sensors in Use</i>	<i>Sensor addresses available</i>	<i>Modules</i>	<i>Modules Available</i>
1	19	80	56	43
2	35	64	54	45
3	31	68	48	51
4	58	41	80	19
5				
6	19	80	35	64
7				
8				
9				
	<b>162</b>	<b>333</b>	<b>273</b>	<b>222</b>
		<b>67%</b>		<b>45%</b>

<i>Pier D,Dy &amp; Dx FAP (XLS1000) Pier Dx Lwr Lvl Elect. Sub-Dx124</i>				
<i>SLC Loop</i>	<i>Sensors in Use</i>	<i>Sensor addresses available</i>	<i>Modules</i>	<i>Modules Available</i>
1	22	77	34	65
2	32	67	47	52
3	55	44	56	43
4	13	86	48	51
5	16	83	61	38
6	23	76	72	27
7	41	58	99	0
8				
9				
	<b>202</b>	<b>491</b>	<b>417</b>	<b>276</b>
		<b>71%</b>		<b>40%</b>

<i>NTE FAP (XLS1000) NTE Lwr Lvl Fire Cmd Rm-NTE253A</i>				
<i>SLC Loop</i>	<i>Sensors in Use</i>	<i>Sensor addresses available</i>	<i>Modules</i>	<i>Modules Available</i>
1	53	46	47	52
2	57	42	51	48
3	15	84	47	52
4	10	89	7	92
5	32	67	43	56
6	59	40	53	46
7	10	89	26	73
8				
9				
	<b>236</b>	<b>457</b>	<b>274</b>	<b>419</b>
		<b>66%</b>		<b>60%</b>

<i>Pier E FAP (XLS1000) Pier E Lwr Lvl Fire Cmd Rm-E1802</i>				
<i>SLC Loop</i>	<i>Sensors in Use</i>	<i>Sensor addresses available</i>	<i>Modules</i>	<i>Modules Available</i>
1	12	87	53	46
2	7	92	51	48
3	36	63	69	30
4	0	99	8	91
5	30	69	70	29
6	76	23	52	47
7	19	80	54	45
8	2	97	8	91
9	6	93	9	90
	<b>188</b>	<b>703</b>	<b>374</b>	<b>517</b>
		<b>79%</b>		<b>58%</b>

<i>Pier Ex FAP (XLS1000) Pier E Sterile Corr Fire Cmnd Rm-E2106A</i>				
<i>SLC Loop</i>	<i>Sensors in Use</i>	<i>Sensor addresses available</i>	<i>Modules</i>	<i>Modules Available</i>
1				
2				
3				
4				
5				
6	17	82	45	42
7	29	70	57	72
8	15	84	27	57
9	14	85	42	99
<hr/>				
	<b>75</b>	<b>321</b>	<b>171</b>	<b>270</b>
		<b>81%</b>		<b>61%</b>

---

**Appendix B – Design Review Comments with Responses**

---

**Draft-Final**

submittal / phase

**10/29/2021**

submittal date

**JMT**

Designer of Record

**WC-will comply, DE-designer to evaluate, DC-delete comment****TD/SKhatri**

project manager

contract number

No.	Drawing and/or Section No.	Comments	RCA	SC	Discipline	Designer Comments	Back check
1	General	Change the name of the report to MEP Capacity Study for Airport Concessions at BWI Marshall Airport		Design Review Meeting		Will comply.	
2	Executive Summary - Part A.	The first paragraph should read as follows: This Study Report provides an overview of the available capacity of the mechanical, plumbing, electrical, information technology and security, and fire protection systems that are currently available at the Baltimore/Washington International Thurgood Marshall Airport (BWI Marshall Airport or Airport) to support the concession program. This information will provide an understanding of the building services that are available to support future concession development.		MW		Will comply.	
3	Executive Summary - Part B.	Add the word "provide" to the first sentence of the second paragraph, between "and" and "a".		MW		Will comply.	
4	Executive Summary - Part B.	The third paragraph should read as follows: The study is based on a review of existing plans, site walk-thrus, coordination with the Maryland Department of Transportation Maryland Aviation Administration (MDOT MAA), review of existing metering data and HVAC control system data, and analysis to calculate available spare capacity.		MW		Will comply.	
5	Executive Summary - Part B.	Delete the bullet list after the third paragraph.		MW		Will comply.	
6	Study Report - Part A.	Delete the first paragraph.		MW		Will comply.	
7	Study Report - Part A.	The second paragraph should read as follows: To support the development and implementation of future concession program master plans at BWI Marshall Airport, this study documents at a high level, the capacity available in the mechanical, plumbing, electrical, information technology and security, and fire protection systems at the BWI Marshall Airport Main Terminal and the connecting Concourses A, B, C, D and E to support the concessionaires.		MW		Will comply.	
8	Study Report - Part C.	Add existing gas distribution system pressure to the narrative.		Design Review Meeting		Will comply.	
9	Study Report - Part C.	Coordinate plumbing narrative with Peter Charles.		Design Review Meeting		Will comply.	



No.	Drawing and/or Section No.	Comments	RCA	SC	Discipline	Designer Comments	Back check
10	Study Report - Part E.	Modify report to clarify relationship between Smart City and utility providers like Comcast.		Design Review Meeting		Will comply.	
11	Study Report - Part E.	If concessionaire makes changes that affect Airport Security then the changes must be coordinated with MAA security...for example, card readers connected to MAA System vs tenant owned card access.		Design Review Meeting		Will comply.	
12	A/B Core Exhibits	Add notes to the MEP/IT plans referring back to arch plans for changes to the AB expansion. Area should be clouded, use similar approach and color scheme as restroom (red dash)		Design Review Meeting		Will comply.	
13	Mechanical Exhibits	If the VAV capacity is changed, AHU and VAVs must be balanced.		Design Review Meeting		Will comply.	
14	A/B Core Lower Level Technology Systems	Sheet 68 - Telecom AT109 mislabeled.		Design Review Meeting		Will comply.	

**Draft**  
submittal / phase

**9/10/2021**  
submittal date

**JMT**  
Designer of Record

**WC-will comply, DE-designer to evaluate, DC-delete comment**

**TD/SKhatri**  
project manager

contract number



No.	Drawing and/or Section No.	Comments	RCA	SC	Discipline	Designer Comments	Back check
1	Throughout Document	All references to MAA should be changed to MDOT MAA		MW		Will comply.	
2	Throughout Document	All references to BWI should be changed to BWI Marshall Airport or Airport		MW		Will comply.	
3	I	The Executive Summary should be completely revised and restated. The existing content is duplicate to Section II - Study Report		MW		We have maintained the introduction and the approach in the executive summary and added a summary for each of the systems under a "Summary of Findings" paragraph.	
4	II.A	The first Paragraph should read as follows: The Maryland Department of Transportation Maryland Aviation Administration (MDOT MAA) is preparing to issue an RFP for a concession developer at Baltimore/Washington International Turgood Marshall Airport (BWI Marshall Airport or Airport). This Study Report provides an overview of the available capacity of the mechanical, electrical, plumbing, fire protection and information technology services that are currently available at the Airport to support the concession program. This information will provide proponents with an accurate understanding of the building services that are available to support future concession development.		MW		Will comply.	
5	II.F.3.b	Concourse A/B Core should read A/B Core		MW		Will comply.	
6	II.F.3.h	DE Connector should read D/E Core		MW		Will comply.	
7	Entire Document	Change the orientation of the report to landscape		MW		Will comply.	
8	Appendix A - Exhibits	Concession Unit Numbers are incorrect, please reference the attached exhibit (produced by William Garmer) for the correct concession unit numbers		MW		Will comply.	
9	Appendix A - Exhibits	Ensure the consist use of color indicators for concession type. Colors used must be the same as the attached exhibit produced by William Garmer.		MW		Will comply.	
10	Appendix A - Exhibits	The Location Plan must be modified to change Concourse A/B to A/B Core and DE Concourse to D/E Core		MW		Will comply.	
11	II.F	All ICT services to concessionaires should be provided by SmartCity. Please review with MDOT MAA IT or OCM		MW		Will comply.	

#### IV. DESIGN REPORT GENERAL INFORMATION

Date	November 30, 2021
Report Phase	<input type="checkbox"/> Draft <input type="checkbox"/> Draft-Final <input checked="" type="checkbox"/> Final
Airport	<input checked="" type="checkbox"/> BWI Marshall <input type="checkbox"/> Martin State
A/E Contract Number	MAA-AE-18-010
A/E Task/Subtask Number	8520
A/E Task/Subtask Title	MEP Capacity Study for Airport Concession RFP
Construction Contract Number	N/A
Construction Contract Title	N/A
Construction Task Number	N/A
Construction Task Title	N/A
<b>CONSULTANT'S CONTACT INFORMATION</b>	
Prime Consultant	Michael Baker International
Subconsultants	Schiller and Hersh, Ross & Baruzzini
Consultant's Project Manager	Tracy Hollida
Consultant's Task Manager	Sunil Khatri
Task Manager's Phone Number	410-689-3431
Task Manager's Email Address	Sunil.Khatri@mbakerintl.com

#### Consultant Sign-off

Consultant signatures below certify that Consultant has reviewed the documents for completeness and coordination per MDOT MAA Design Standards and project requirements and attests to their review of said documents as submitted to MDOT MAA.

Position	Name	Signature	Consultant Name
Task/ Project Manager	Sunil Khatri		Michael Baker
QA/QC Manager	Donna Kolb		Michael Baker

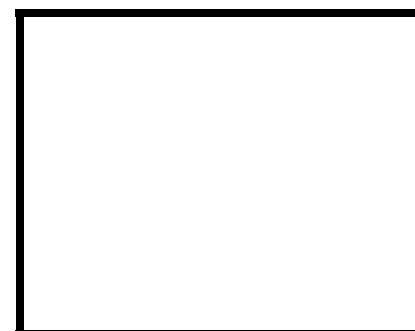

#### Professional Certification:

"I HEREBY CERTIFY THAT THESE DOCUMENTS WERE PREPARED OR APPROVED BY ME, AND THAT I AM A DULY REGISTERED ENGINEER UNDER THE LAWS OF THE STATE OF MARYLAND"

License Number: \_\_\_\_\_

Expiration Date: \_\_\_\_\_